



DataVS2 - VSM



Instruction Manual



Datalogic Automation S.r.l.
Via Lavino, 265
40050 - Monte S. Pietro
Bologna - Italy

DataVS2 - VSM Instruction Manual

Ed.: 05/2011

© 2011 Datalogic Automation S.r.l. ♦ ALL RIGHTS RESERVED. ♦ Protected to the fullest extent under U.S. and international laws. Copying, or altering of this document is prohibited without express written consent from Datalogic Automation S.r.l.

Datalogic and the Datalogic logo are registered trademarks of Datalogic S.p.A. in many countries, including the U.S.A. and the E.U.

All brand and product names mentioned herein are for identification purposes only and may be trademarks or registered trademarks of their respective owners.

Datalogic shall not be liable for technical or editorial errors or omissions contained herein, nor for incidental or consequential damages resulting from the use of this material.

12/05/11

CONTENTS

COMPLIANCE	v
CE Compliance.....	v
FCC Compliance	v
GENERAL VIEW	vi
1 GENERAL INFORMATION	1
1.1 Conventions Used in the Manual.....	1
1.2 General Description	1
2 INSTALLATION	2
2.1 Safety Recommendations.....	2
2.2 DataVS2 VSM DIN Rail Mounting	2
2.3 DataVS2 VSM Panel Mounting.....	4
3 ELECTRICAL CONNECTIONS	6
3.1 Pinouts.....	6
3.1.1 DataVS2 OBJ/AOR Sensor	6
3.1.2 DataVS2 ID Sensor	6
3.1.3 VSM Monitor	7
3.2 Point-to-Point Connection.....	7
3.3 LAN Connection.....	7
3.4 Ground Connection.....	8
3.5 DataVS2 Power Connection.....	8
4 FIRST APPROACH TO VSM	9
4.1 Introduction	9
4.2 VSM User Interface	9
4.3 Connection to DataVS2	10
5 MONITORING AN INSPECTION	12
6 INSPECTION CHANGE	13
7 INSPECTION PARAMETER CHANGE	14
7.1 Current Inspection Change.....	14
7.2 Camera Parameter Change.....	15
7.3 Tool Parameters Change.....	17
7.3.1 Tool Selection	17
7.3.2 ROI Change.....	18
7.3.3 Other Parameter Changes of the Selected Tool.....	20
7.4 Reference Image Change.....	21
7.5 Trigger Mode Change.....	22
8 ADVANCED FUNCTIONS	23
8.1 Monitor Settings.....	23
8.2 Sensor Settings	24
8.3 Memory Management.....	25
8.3.1 Slot Selection (VSM).....	25
8.3.2 Slot Selection (DataVS2).....	26
8.3.3 Transfer from VSM to DataVS2	26
8.3.4 Transfer from DataVS2 to VSM	27

8.3.5	Cancellation of a VSM Slot	27
8.3.6	Cancellation of a DataVS2 Slot	28
8.3.7	Cancellation of all the VSM Slots.....	28
8.3.8	Cancellation of all the DataVS2 Slots	29
8.4	Factory Reset	29
8.5	Sensor List.....	30
8.6	Users	30
8.6.1	Removal of the Password.....	34
8.7	Language.....	35
8.8	Disconnect.....	35
9	DATAVS2 GUI CONNECTION	36
9.1	VSM General Information	37
9.2	VSM Memory Settings	38
9.3	Firmware Update	39
10	CHECKS AND PERIODIC MAINTENANCE.....	41
11	WARRANTY.....	42
12	SPECIFICATIONS.....	43
13	OVERALL DIMENSIONS.....	44

COMPLIANCE

For installation, use and maintenance it is not necessary to open the reader.

Only connect Ethernet and dataport connections to a network which has routing only within the plant or building and no routing outside the plant or building.

CE COMPLIANCE

Warning: This is a Class A product. In a domestic environment this product may cause radio interference in which case the user may be required to take adequate measures.

FCC COMPLIANCE

Modifications or changes to this equipment without the expressed written approval of Datalogic could void the authority to use the equipment.

This device complies with PART 15 of the FCC Rules. Operation is subject to the following two conditions: (1) This device may not cause harmful interference, and (2) this device must accept any interference received, including interference which may cause undesired operation.

This equipment has been tested and found to comply with the limits for a Class A digital device, pursuant to part 15 of the FCC Rules. These limits are designed to provide reasonable protection against harmful interference when the equipment is operated in a commercial environment. This equipment generates, uses, and can radiate radio frequency energy and, if not installed and used in accordance with the instruction manual, may cause harmful interference to radio communications. Operation of this equipment in a residential area is likely to cause harmful interference in which case the user will be required to correct the interference at his own expense.

GENERAL VIEW

DataVS2-VSM

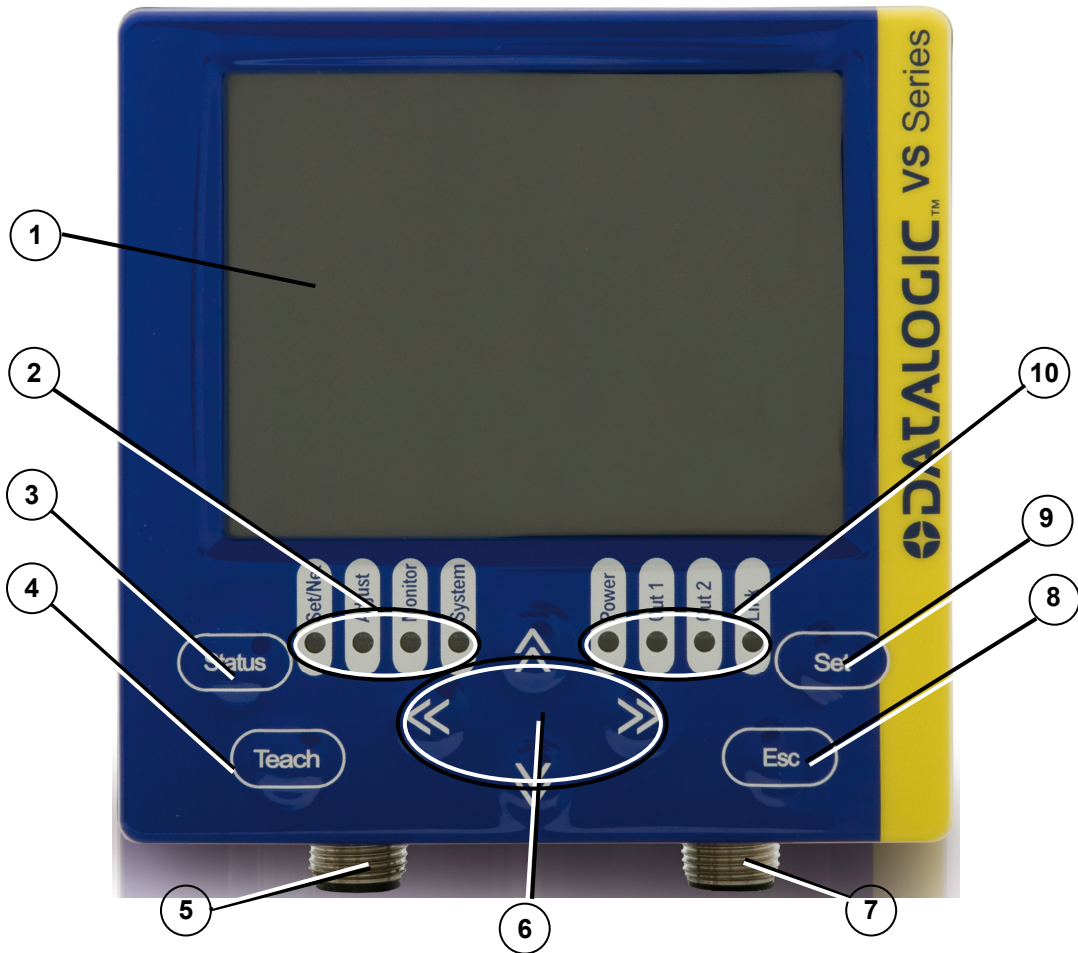

Figure A

- | | |
|--|------------------------------|
| ① Monitor (color 3.5" LCD 320x240 pixel) | ⑥ ARROW Buttons |
| ② Status LEDs | ⑦ Ethernet Network Connector |
| ③ STATUS Button | ⑧ ESC Button |
| ④ TEACH Button | ⑨ SET Button |
| ⑤ Power Supply Connector | ⑩ Power, OUT, ETH Link LEDs |

1 GENERAL INFORMATION

1.1 CONVENTIONS USED IN THE MANUAL

This manual was developed to provide clear and precise information on how to use the DataVS2 VSM system.



NOTE

This refers to information of particular interest.

1.2 GENERAL DESCRIPTION

The VSM is a visualisation and control device compatible with all the vision sensors of the DataVS2 series. The monitor can be connected directly to one sensor or installed on a network.

Once connected, the VSM monitor displays the processed images together with the results of the analysis tools as well as a few statistics relative to control results. The device controls the functioning of the vision sensors as well as changing the parameters in order to adapt and vary the DataVS2 configuration without using a PC.

VSM allows simple and rapid sensor setting. The user can immediately access all the functions: change an inspection, modify in real time the inspection in execution, view results and statistics.

Once the DataVS2 settings have been completed, the VSM can be used to view the results of the current inspection, or it can be disconnected and the sensor will continue to function in stand-alone mode.

Thanks to the wide range of functions, the VSM represents an excellent and complete HMI interface, ideal for automatic production lines controlled by operators.



NOTE

The Datalogic DataVS2 vision sensor (machine vision) is easy to use and has advanced inspection functions which makes it very suitable to many different fields (quality control on production lines or automatic material handling are just a few examples).

2 INSTALLATION

2.1 SAFETY RECOMMENDATIONS

- Read the instruction manual carefully before installing the sensor and VSM.
- Make sure that the product is suitable for the system that you intend to set up.
- Connect the cables to the devices with the poles in the right direction.
- Power up the devices following the instructions contained in the Manual.
- Protect all devices against dust, dirt and humidity.
- Never spill liquids on the devices
- It is strictly prohibited to use DataVS2 in applications where the safety of persons and/or things is guaranteed by the correct functioning of the device.
- Always comply with all safety rules and regulations.
- Never use the devices in environments where there is a risk of explosion.
- Do not subject the devices to strong and continuous vibration.

2.2 DATAVS2 VSM DIN RAIL MOUNTING

There is a slot on the rear of the VSM which allows the user to connect the device to a DIN guide.

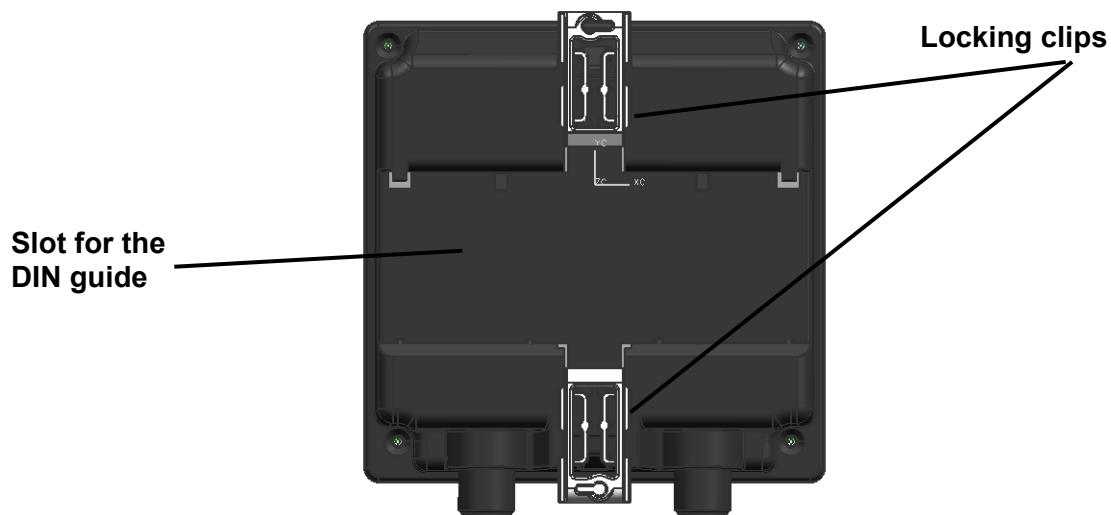

Wedge the VSM unit in the DIN rail. First set the upper part of the monitor and then press down the lower part.

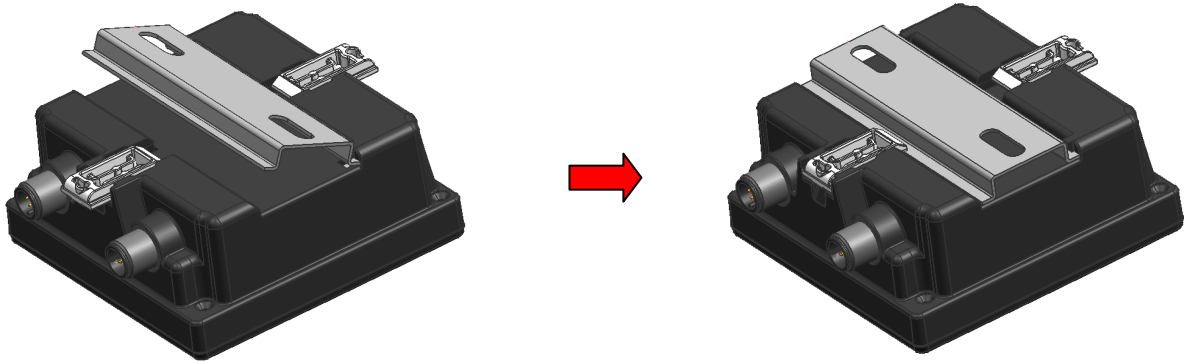

Once inserted, block the VSM monitor using the two white side locking clips.

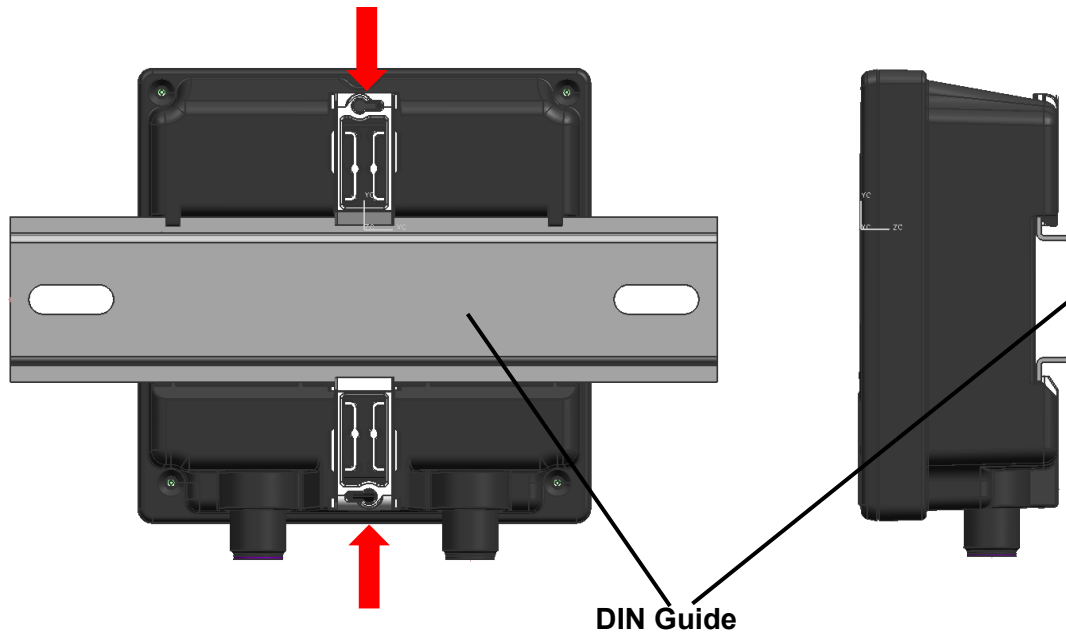

2.3 DATAVS2 VSM PANEL MOUNTING

The VSM can also be installed on a panel. All the accessories for this mounting are included in the package.

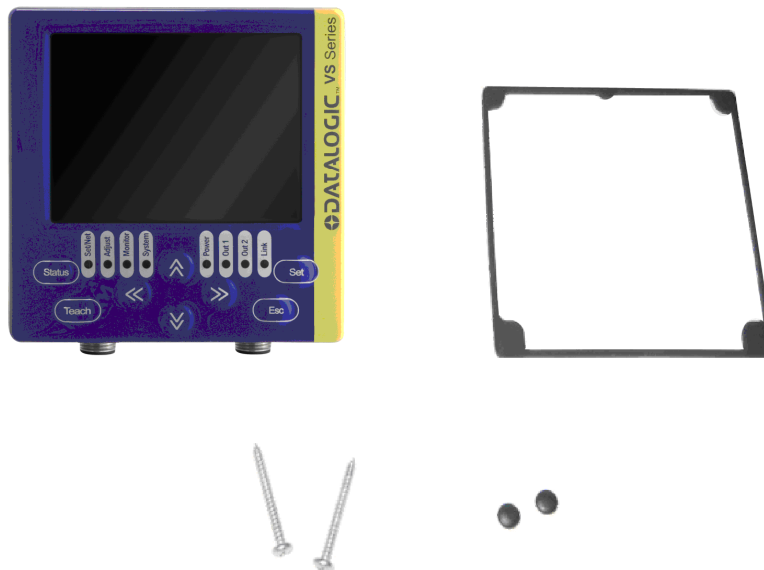

First, carefully place the rubber seal around the VSM unit.

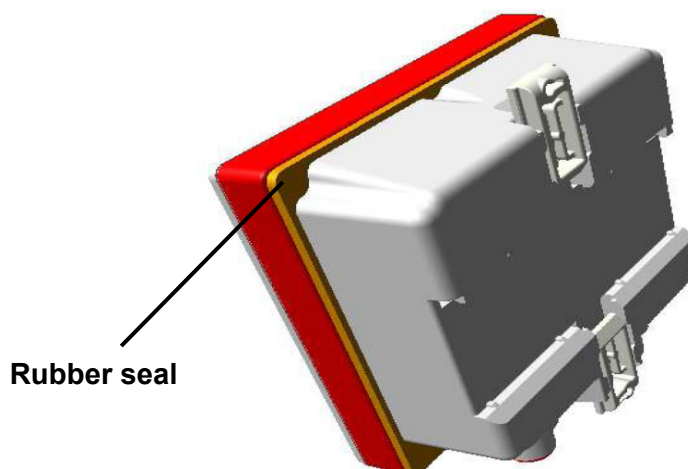

Then fix the VSM on the panel using the two locking screws and the two rubber caps.

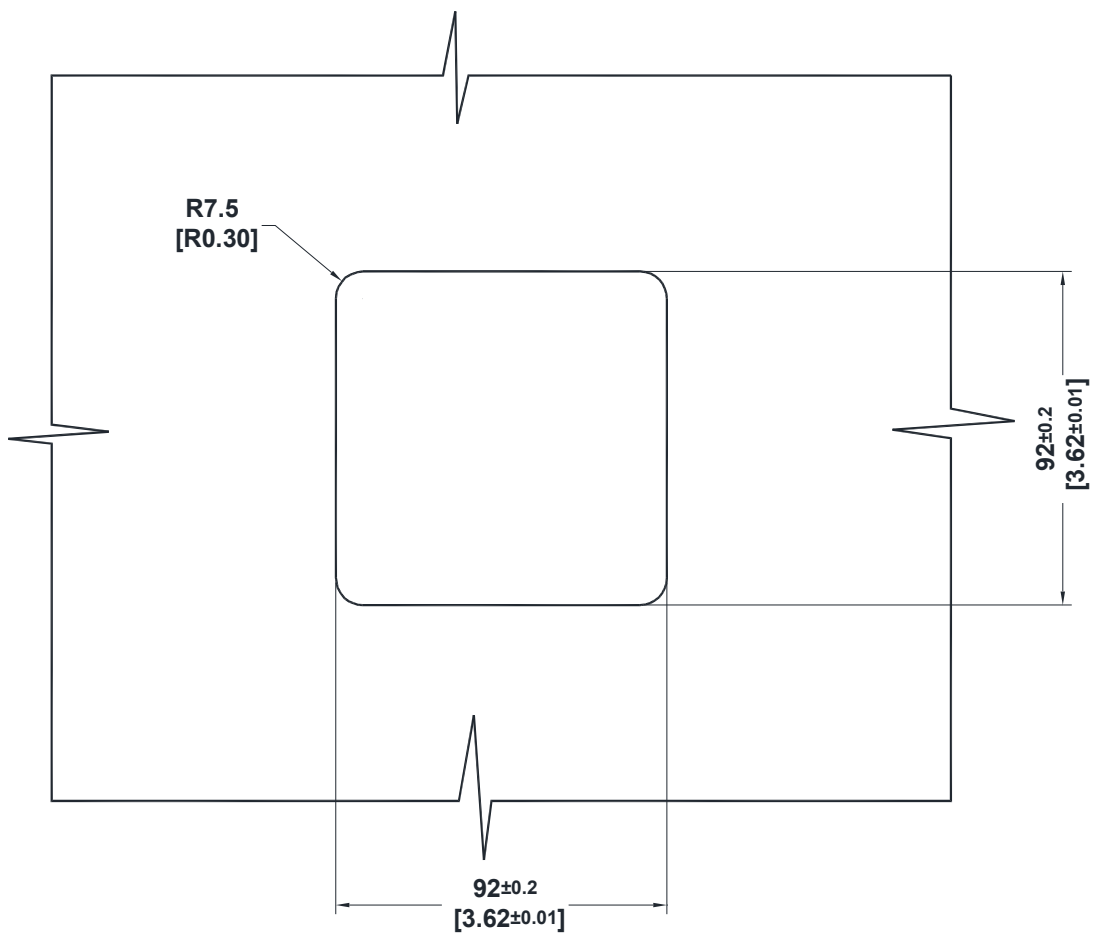
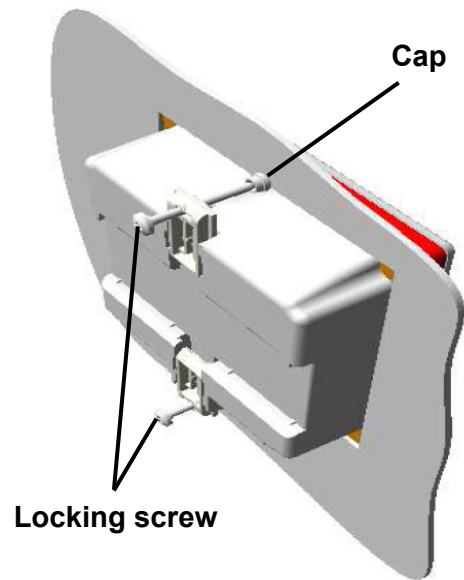

3 ELECTRICAL CONNECTIONS

3.1 PINOUTS

3.1.1 DataVS2 OBJ/AOR Sensor

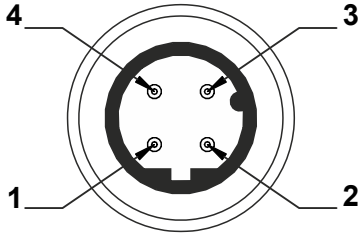
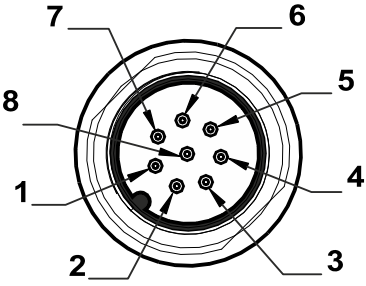
	
<p>M12 Reverse Keyed 4-Pin Male (Ethernet connection)</p> <p>pin 1: Ethernet RX+ pin 2: Ethernet TX+ pin 3: Ethernet RX- pin 4: Ethernet TX-</p>	<p>M12 8-Pin Male (power supply and I/O)</p> <p>pin 1: white : Digital Input 1 pin 2: brown: +24 Vdc pin 3: green : Output 4 / Strobe for external illuminator pin 4: yellow: Output 1 pin 5: grey: Output 2 pin 6: pink: Output 3 pin 7: blue: Ground pin 8: red: External Trigger</p>

3.1.2 DataVS2 ID Sensor

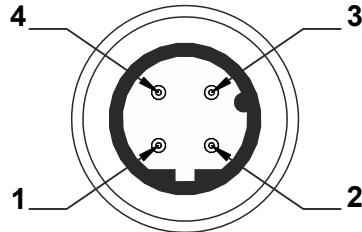
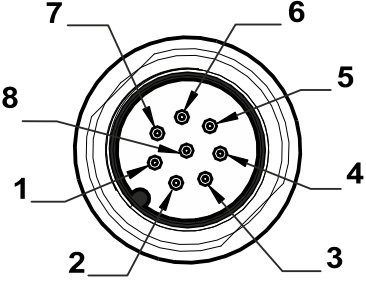
	
<p>M12 Reverse Keyed 4-Pin Male (Ethernet connection)</p> <p>pin 1: Ethernet RX+ pin 2: Ethernet TX+ pin 3: Ethernet RX- pin 4: Ethernet TX-</p>	<p>M12 8-Pin Male (power supply and I/O)</p> <p>pin 1: white : RS-232 Rx pin 2: brown: +24 Vdc pin 3: green : Output 4 / Strobe for External Illuminator pin 4: yellow: Output 1 pin 5: grey: Output 2 pin 6: pink : RS-232 Tx pin 7: blue: Ground pin 8: red: External Trigger</p>

3.1.3 VSM Monitor

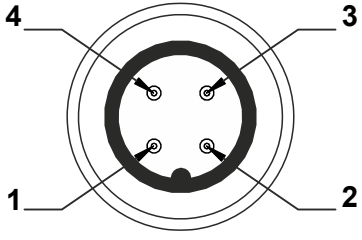
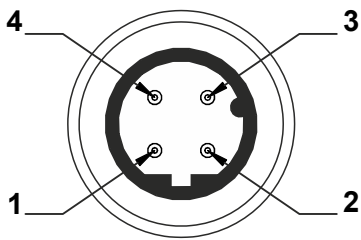
 <p>Diagram showing the pin configuration for the M12 4-Pin Male connector. The pins are numbered 1 through 4. Pin 1 is at the top-left, pin 2 at the top-right, pin 3 at the bottom-left, and pin 4 at the bottom-right.</p>	 <p>Diagram showing the pin configuration for the M12 Reverse Keyed 4-Pin Male connector. The pins are numbered 1 through 4. Pin 1 is at the top-left, pin 2 at the top-right, pin 3 at the bottom-left, and pin 4 at the bottom-right. A key is visible on the right side of the connector.</p>
<p>M12 4-Pin Male (Power supply)</p> <p><i>pin 1: +24 Vdc</i> <i>pin 2: Reserved</i> <i>pin 3: GROUND</i> <i>pin 4: Reserved</i></p>	<p>M12 Reverse Keyed 4-Pin Male (Ethernet connection)</p> <p><i>pin 1: Ethernet RX+</i> <i>pin 2: Ethernet TX+</i> <i>pin 3: Ethernet RX-</i> <i>pin 4: Ethernet TX-</i></p>

3.2 POINT-TO-POINT CONNECTION

Connect DataVS2 to VSM using the specific connection cable (DataVS-CV-VSM-xx).

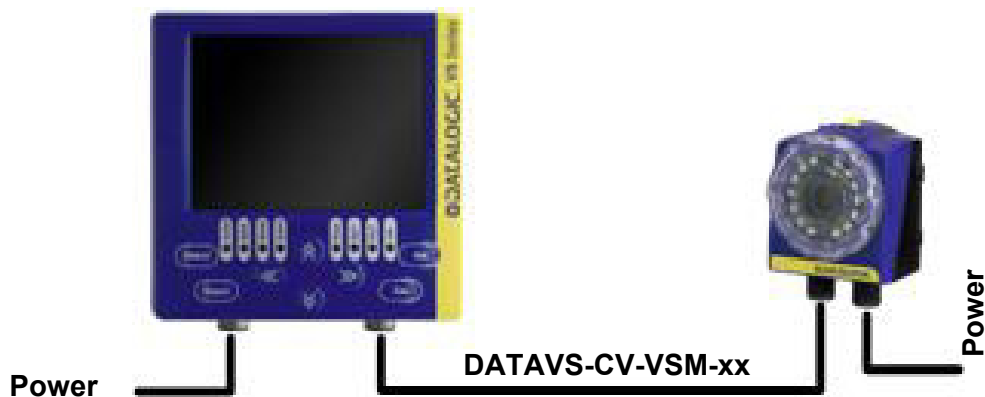

3.3 LAN CONNECTION

Connect DataVS2 and VSM to LAN using the specific connection cable (DataVS-CV-RJ45D-03).

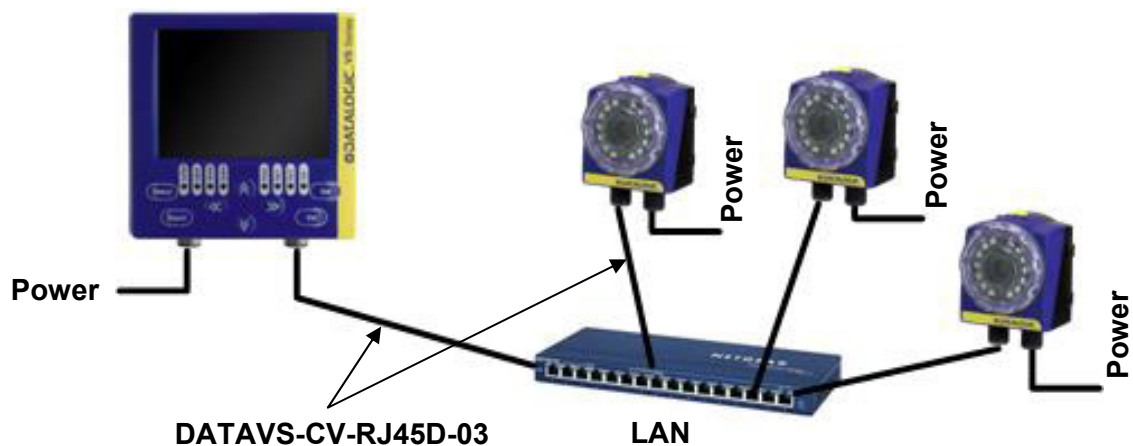

3.4 GROUND CONNECTION

To comply with the EMC requirements, the Ethernet cable shield has to be grounded. (Use the yellow/green cable supplied with the VSM).

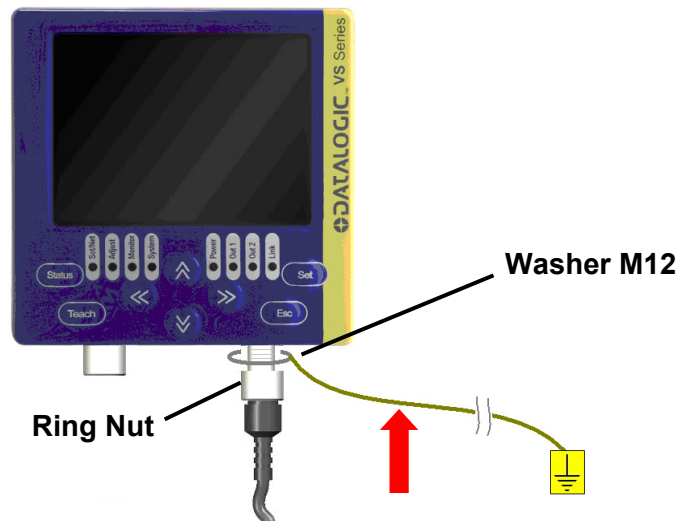

Insert the washer M12 on the yellow/green cable in the VSM connector and then screw the Ethernet cable until the ring nut reaches the washer.

Warnings

- Insert the cable into the correct connector following the key indications inside the body
- After inserting the cable, turn the ring nut anticlockwise to ensure connection
- Never force the cable inside the connectors.
- Make sure that every cable is connected to the right connector
- Before disconnecting the cable, completely turn the ring nut anticlockwise

3.5 DATAVS2 POWER CONNECTION

Connect the power and I/O cable (CV-A1-36-B-xx) inserting it into the connector identified by the icon (PWR-I/O).



4 FIRST APPROACH TO VSM

4.1 INTRODUCTION

The configuration of the DataVS2 vision sensor has to be made only through DataVS2 GUI.

To simplify the instructions described in this manual, the pressing of the buttons on the VSM user interface will be indicated as follows:



4.2 VSM USER INTERFACE

The chart shown below provides a general overview of the user interface on the VSM user interface. Please note however that the functions of the buttons vary according to the operating mode selected by the user. Please consult the next chapters for further details on how the system reacts to the pressing of such buttons.

BUTTON	
Button ID	Main Functions
Status	Go to main menu ("System")
Teach	Go to "Adjust" status
Set	Confirms selected option Confirms setting value
Esc	Exit without saving Back to previous screen
Arrows	Changes selected option Movement/resizing of the ROI Changes the parameters

LED		
LED ID	Colour	Meaning
Power	Green	VSM correctly powered
Out 1	Orange	Digital output 1 active
Out 2	Orange	Digital output 2 active
Link	Green	VSM correctly connected to LAN
Set/Net	Green	Current status: Setup
Adjust	Green	Current status: Adjust
Monitor	Green	Current status: Monitor
System	Green	Current status: System

4.3 CONNECTION TO DATAVS2

When the VSM is powered, the welcome screen will be displayed on the monitor.



After a few seconds, a “Net Discovery” is automatically carried/out in order to find how many DataVS2 are present in the LAN network.

At the end of the discovery, a panel will be displayed listing all the DataVS2s found.



NOTE

The VSM suggests to connect the last sensor used selecting it from the list of DataVS2 (shown in green).

Sensor List		
Name	IP Address	Netmask
DataVS2_12mm	172.27.101.24	255.255.0.0
-	-	-
-	-	-
-	-	-
-	-	-
-	-	-
-	-	-
-	-	-
-	-	-
-	-	-

 Select the sensor and hit SET to connect



NOTE

*If no devices have been found in the first discovery, a new search can be carried-out by pressing **TEACH**.*

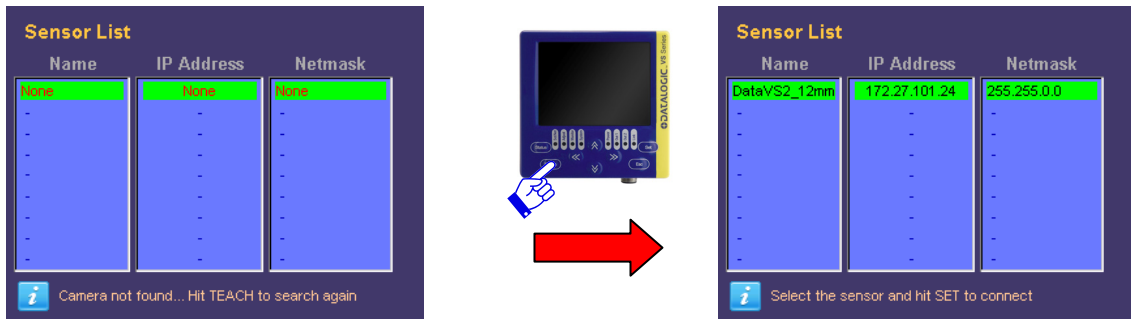

To connect a sensor, just select it from the list and press **SET**.



Once connected, the VSM enters in the monitor status displaying the inspection currently being carried/out by the DataVS2.

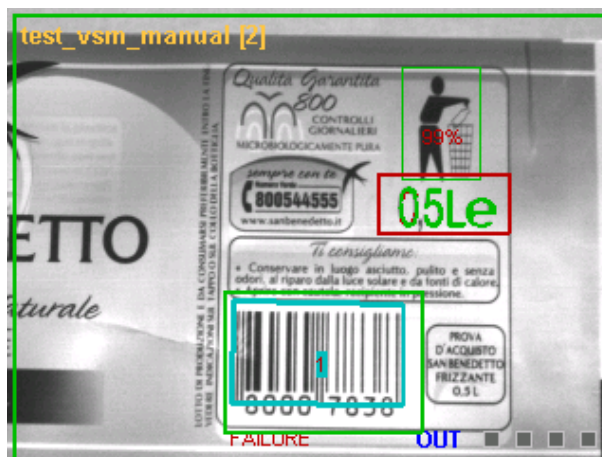



If the field is out of focus, the user can adjust it by regulating directly the focus ring on the sensor.

5 MONITORING AN INSPECTION

The “Monitor” mode allows the user to check the correct functioning of the inspection defined previously.

The chart shown below provides a description of the main modes available and shows how to enable viewing.

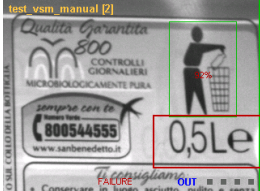
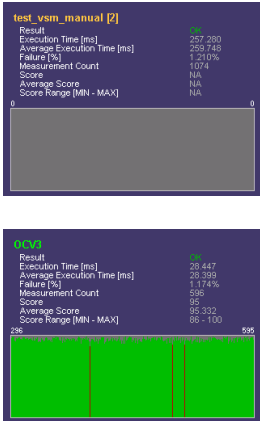
Mode	Example	Enable	Description
Standard			The monitor displays the sensor field focus in full screen mode. The following information is also displayed: <ul style="list-style-type: none"> • Inspection name and relative memory slot • ROI • Inspection result • Logic value of the outputs
Tool Result		DOWN ARROW	This screen shows the tool result of the current inspection. The results of all the inspection tools can be displayed using the RIGHT/LEFT ARROWS .
Display On Condition		ESC BUTTON	This mode displays only the images that comply with the condition specified during inspection configuration using the DataVS2 GUI.
Zoom Mode		UP ARROW	An image of the sensor field focus is displayed on the monitor with 200% zoom. To move the zoom area, use the ARROW buttons. Press ESC to exit zoom mode.
Statistics		SET BUTTON	Statistics on the inspection results are displayed on the monitor, including: <ul style="list-style-type: none"> • <u>Result</u> • Current inspection outcome • <u>Execution time (ms)</u> • Total inspection execution time • <u>Failure (%)</u> • % of failed inspections of the total number executed • <u>Score</u> • Current inspection result • <u>Etc...</u> The statistics of the single tools can be displayed by pressing STATUS . Use UP/DOWN ARROWS to scroll the tool panels. Use RIGHT/LEFT ARROWS to change the scale of the graphics.

6 INSPECTION CHANGE

To change the inspection currently in execution on the DataVS2, the user must start from the monitor screen and press **TEACH**. The selection panel will be displayed:



Press **SET** on “**Change Current Inspection**” to access another panel where the user can select the inspection to carry-out.

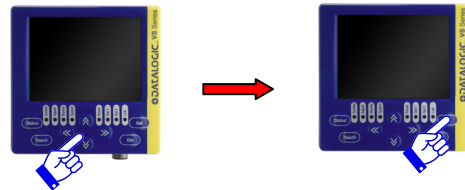
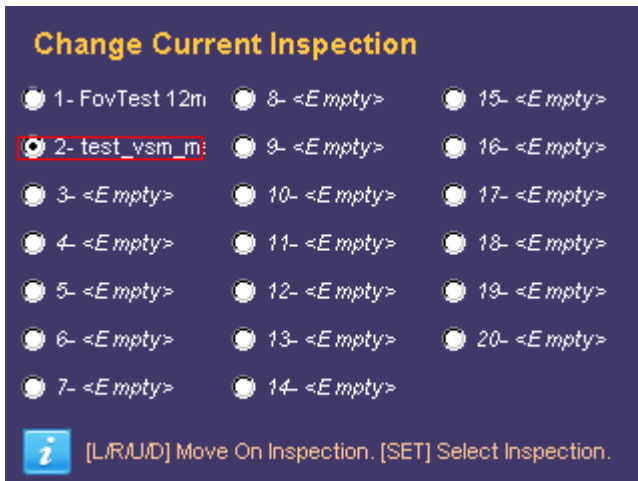

Use the **ARROWS** to move the focus on the desired inspection and press **SET** to start the inspection.

At this point DataVS2 carries-out the new inspection and the monitor status is restored.

7 INSPECTION PARAMETER CHANGE

7.1 CURRENT INSPECTION CHANGE

To change the sensor parameters, press **TEACH** in the monitor mode. The following panel is displayed:

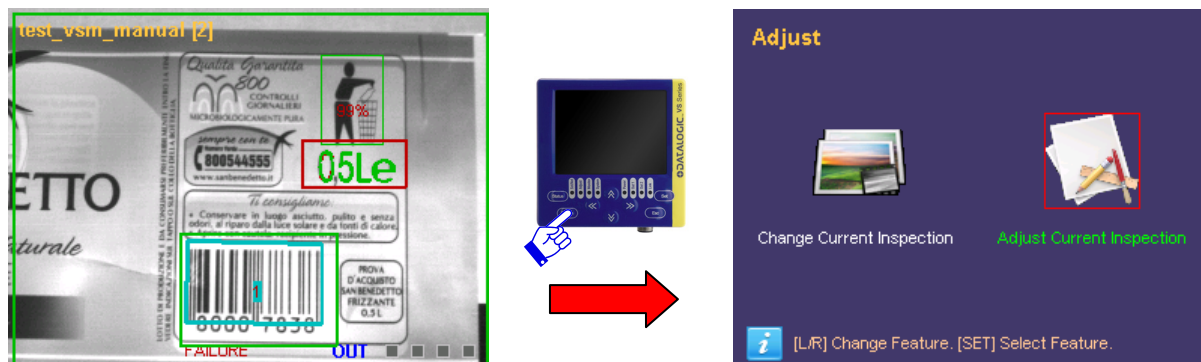

At this point the user can choose to change the current inspection or modify the parameters.

Selecting **“Adjust Current Inspection”** the user accesses the main panel of the Adjust status:



As you can see in the image, the VSM is split into two main areas: the field range of the camera and the configuration options available.

The image acquired by the sensor is displayed in the first area. The configuration options are displayed on the right side of the monitor, where the user can scroll through the options using the **UP/DOWN ARROWS**.



7.2 CAMERA PARAMETER CHANGE

Selecting the **“Camera”** option and pressing **SET**, the user accesses some DataVS2 parameters such as: *exposure time, gain and illuminator operating mode*.

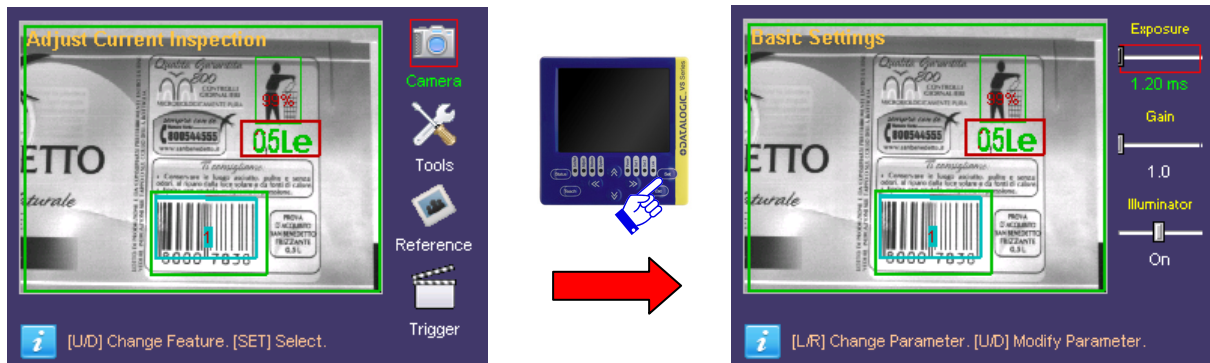

The user can change the focus between the objects on the panel by using the **UP/DOWN ARROWS**. To change the parameter value, once selected the focus, the user has to use the **RIGHT/LEFT ARROWS**.

Parameter	Description	Change
Exposure time	The exposure time identifies the period that the lens remains open and allows light to reach the CMOS mounted on the sensor. Therefore, the longer the exposure time, the brighter the image will be. On the other hand, increasing the exposure times increases the risk of acquiring blurred images where the detail being monitored moves at a certain speed. If the images of objects that move quickly are not very bright, it is recommended to adjust the gain settings.	To adjust the exposure time, move to the option and use the RIGHT/LEFT ARROW buttons. Press STATUS to change the scale of the slider values. (At each pressing the scale is increased of one order of magnitude).
Gain	The gain setting allows you to adjust the brightness of the image acquired by the sensor by amplifying the signal transmitted by the CMOS to the processing unit. Increasing the gain setting, however, also increases the disturbance on the image which decreases its quality.	To adjust the gain setting, move to the option and use the RIGHT/LEFT ARROW buttons.
Illuminator	This parameter is referred to the illuminator inside the sensor and only one of the three options can be selected: OFF, ON and POWER.	To adjust the gain setting, move to the option and use the RIGHT/LEFT ARROW buttons.

Once the camera settings have been completed, it is possible to return to the Setup menu by pressing **ESC**.

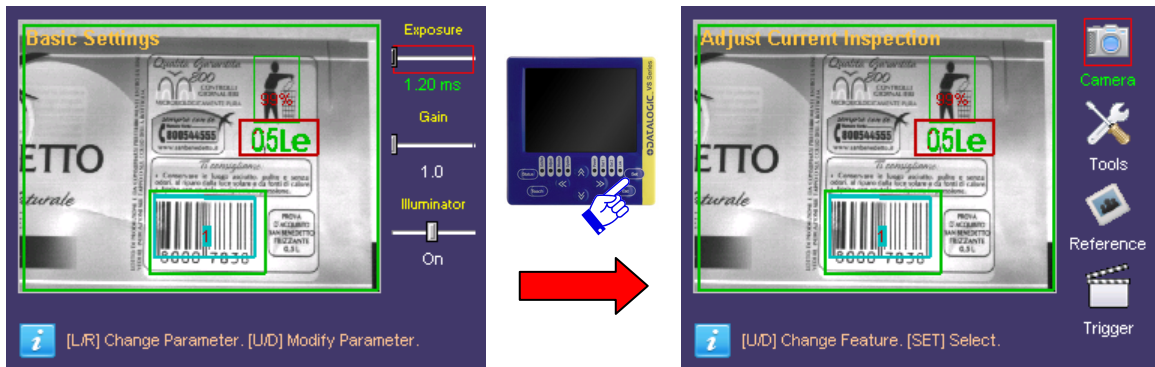

If no other change has to be made, press **ESC** to return to the “Monitor” status.

If inspection parameters have been changed, another panel will be displayed requesting the saving of the changes:

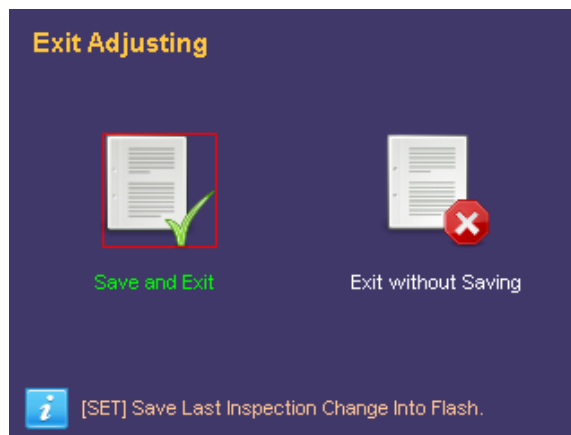

To save the new data in the memory select “**Save and Exit**” using the SET button.

If the changes must have to be cancelled, select “**Exit without Saving**” using the SET button.

At this point the system returns to the monitor status.

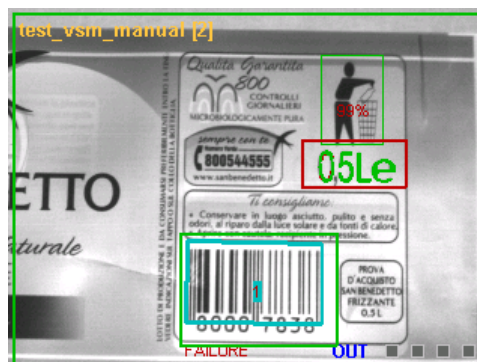

7.3 TOOL PARAMETERS CHANGE

7.3.1 Tool Selection

Press **SET** on the **“Tools”** icon in the **“Adjust Current Inspection”** panel.

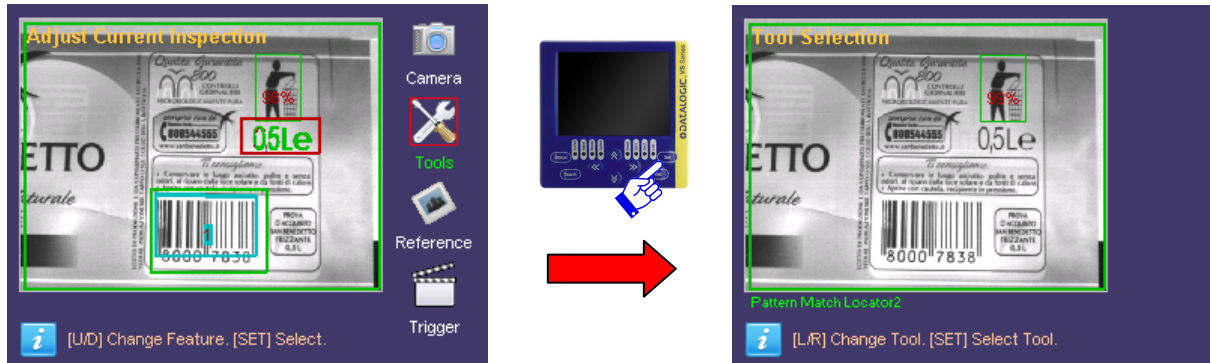

The **“Tool Selection”** panel is displayed and the user can choose the tools to use. All the inspection tools will be displayed one at a time according to the creation order.

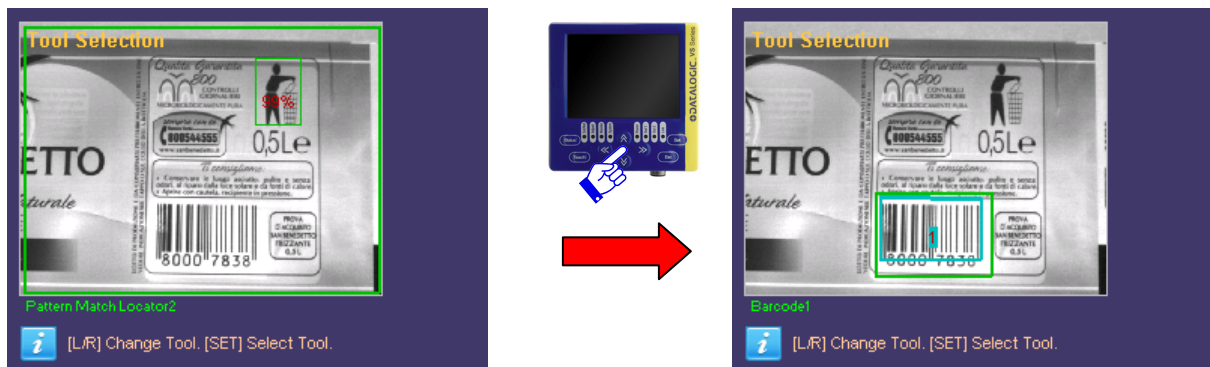

The user can scroll through the different tools using the **RIGHT/LEFT ARROWS**. Press **SET** to confirm.

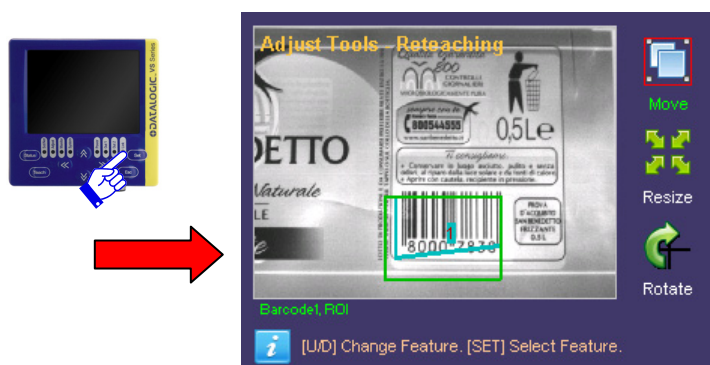

All the parameter change panels can be accessed from here on starting from the ROI panel up to the last one with the parameters that can be changed using the selected tool.



NOTE

All the inspection parameters can be modified only if previously enabled through the DataVS2 GUI panel. For further information, please refer to the DataVS2 Instruction Manual.

7.3.2 ROI Change

To modify a ROI, the tool must have been selected previously and the **“Adjust Tools”** panel opened.

The following operations are possible: *Move, Resize and Rotate*.



NOTE

For the tools characterized by two ROIs, such as the Pattern Match or 360° Pattern Match, the VSM allows editing only the ROI research.



NOTE

Press **TEACH** to confirm. When exiting the change mode, the user is requested to discard changes or save them definitively in the flash memory. All changes will be cancelled by selecting **“Exit without saving”**.

MOVE:



Once selected **“Move”**, the focus is transferred in the field range and the ROI can be moved using the **ARROWS**. Once you have achieved the desired position, press **TEACH** to save changes. Press **ESC** to return to the Setup menu ignoring the changes made.

RESIZE:



If you wish to modify the ROI size, select the **“Resize”** option from the Setup menu (using the **SET** button again). It is now possible to increase or decrease the ROI size using the **ARROW** buttons.

Once you have achieved the desired size, press the **TEACH** button to save the settings and return to the Setup menu. Press the **ESC** button to return to the Setup menu without saving the modifications (the system will request confirmation on the saving option).

ROTATE:



To rotate the ROI, select the **“Rotate”** option from the Setup menu (using the **SET** button again). The ROI will rotate in a clockwise/anticlockwise directly depending of the **RIGHT/LEFT ARROW** button pressed.

Once you have achieved the desired rotation angle, press **TEACH** to save the settings and return to the Setup menu. Press **ESC** to return to the Setup menu ignoring the changes made.

Once the changes on the ROI are completed, the user can exit from the **“Adjust”** mode or proceed with the configuration of the single parameters of the selected tool.

All the parameters that can be changed by the DataVS2 GUI can be scrolled by pressing the **RIGHT/LEFT ARROWS**.

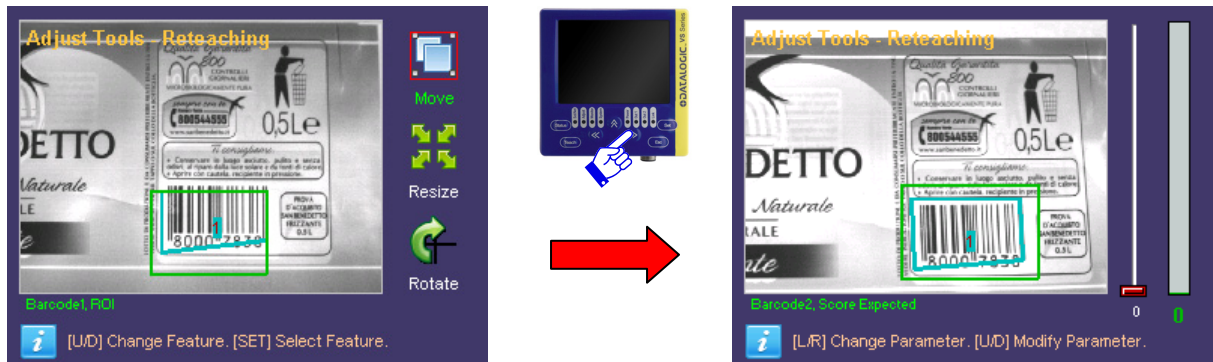

To return to the **“Monitor”** mode the user must return to the higher level panels by pressing **ESC**. If changes have been made, the user is requested to save or ignore them definitively.

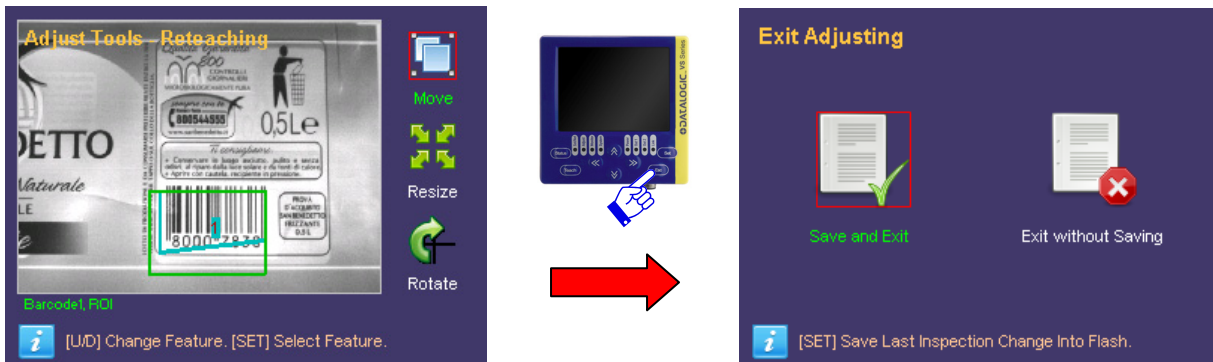

7.3.3 Other Parameter Changes of the Selected Tool

This paragraph explains how to change the parameters that adjust the functioning of a tool.

The VSM monitor is divided as follows: the parameters that the user can change are displayed on the right side, while the image captured by the sensor is displayed on the remaining area. The name of the parameter currently in use is shown on the bottom of the monitor.



The parameters are displayed one at a time, and so the **RIGHT/LEFT ARROWS** must be used to pass from parameter to the another.

To change the current value, use the **UP/DOWN ARROW**. Each time the button is pressed, the value associated to the slider, is increased or decreased of one unit (to change the value faster keep the corresponding button pressed).

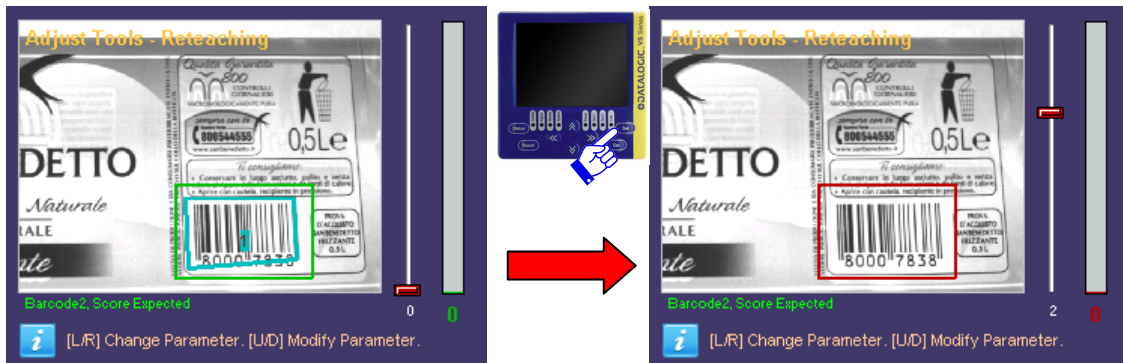

NOTE

The parameters that can be modified vary according to the tool and the inspection selected.

7.4 REFERENCE IMAGE CHANGE

Select **"Reference"** and press **SET** to access the management screen of the reference image.

The screen shows the current image, pressing **TEACH** you can set the current image as the new reference image of the current inspection.



Pressing **STATUS** you can see the current reference image. Pressing **STATUS** again returns to the Reference image management screen.

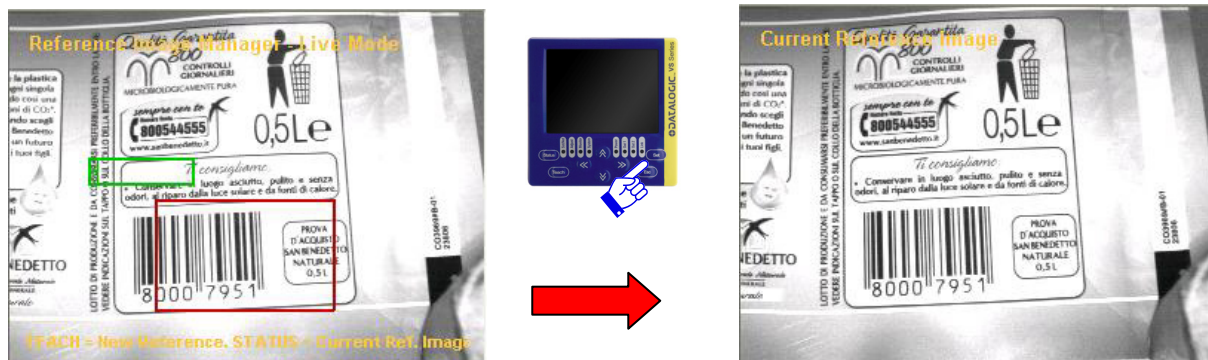

Once you set the reference image, press the **ESC** key to return to the "Adjust current inspection" menu.

7.5 TRIGGER MODE CHANGE

Select "**Trigger**" and press **SET** to access the management screen of the trigger mode.

As you can see in the image, the VSM is split into two main areas: the parameters that the user can change are displayed on the right side of the monitor, while the remaining area displays the image acquired by the sensor.

At the bottom of the monitor also is shown the name of the selected trigger parameter;

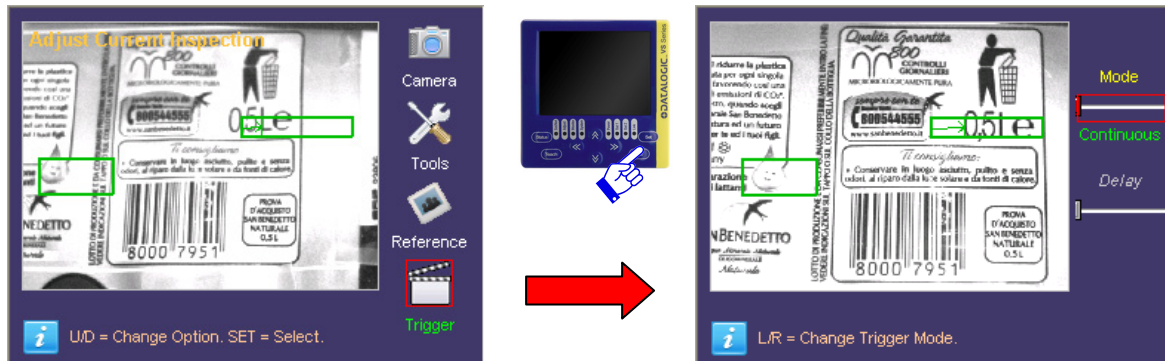

Parameters that can be modified are "Trigger Mode" and "Trigger Delay".

The user can scroll through the parameter using the **UP/DOWN ARROWS**.

To change the current value, use the **UP/DOWN ARROW**. Each time the button is pressed, the value associated to the slider, is increased or decreased of one unit (to change the value faster keep the corresponding button pressed).

8 ADVANCED FUNCTIONS

The previous chapter described the procedure used to modify an inspection for DataVS2. Further to the functions above-described, there are other user settings on the VSM monitor which can be accessed from the System menu.

“System” menu is accessed from “Monitor” pressing **STATUS**.

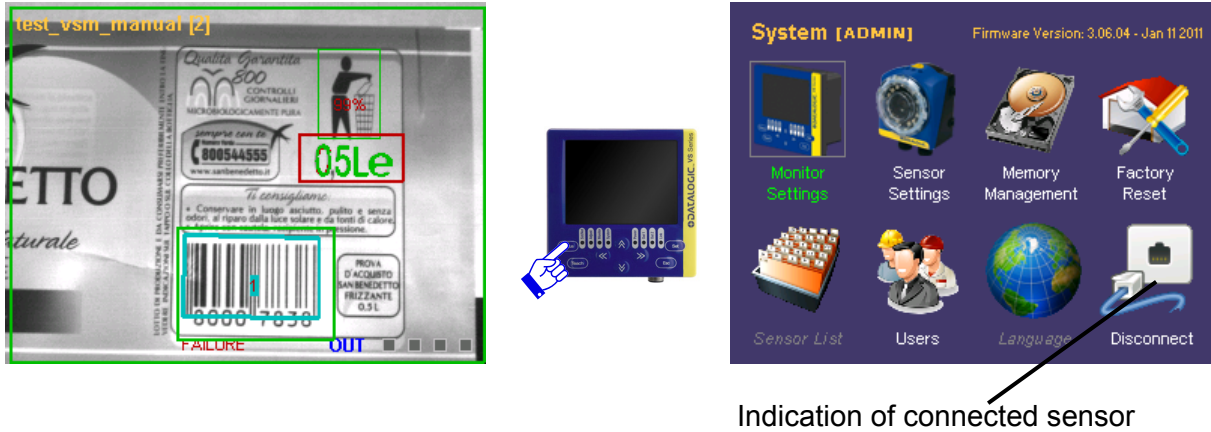

Indication of connected sensor

 **NOTE** The “Disconnect” icon is displayed only when a DataVS2 is connected as it indicates the active status of the sensor connection.

8.1 MONITOR SETTINGS

This panel provides access to VSM information such as *name, serial number, model, etc...* Moreover the *IP and NetMask* network parameters can be modified and the data of the last DataVS2 connected can be displayed.

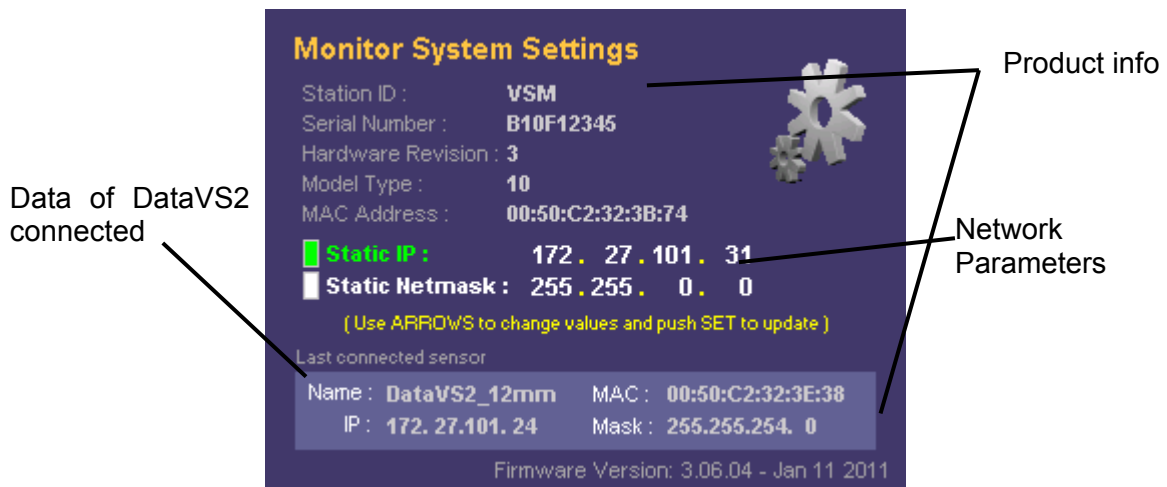

To change the network parameters, the user has to simply move the focus on the desired value and use the **UP/DOWN ARROWS** to increase or decrease the current value. To save the changes press **SET**.



Restart the device to apply correctly the changes.

NOTE

To return to main panel without saving, press **ESC**.

8.2 SENSOR SETTINGS

This panel, when a DataVS2 is connected, can display information such as *name, firmware, Hardware revision, MAC* and modify the sensor network parameters: *IP, Netmask and DHCP...*

Sensor Settings

Sensor Name : DataVS2_12mm
 Hardware Revision : 4
 Model Type : 2
 Firmware Version : ST2.3.0.01.BET A360
 MAC Address : 00:50:C2:32:3E:38
 IP Address : 172.27.101.24
 Subnet Mask : 255.255.0.0

DHCP Status : Disabled
 Static IP : 172 . 27 . 101 . 24
 Static Netmask : 255 . 255 . 0 . 0

(Use ARROWS to change values and push SET to update)

Sensor connected

DataVS2 Info unchangeable

Parameters changeable

To change the network parameters of DataVS2, the user has to simply move the focus on the desired value and use the **UP/DOWN ARROWS** to increase or decrease the current value.

To save the changes press **SET**.



Restart DataVS2 to apply correctly the changes.

NOTE

To return to main panel without saving, press **ESC**.

8.3 MEMORY MANAGEMENT

This paragraph explains how to transfer or cancel a memory slot between VSM and DataVS2.

At this point the user can select the **“Memory Management”** icon and press **SET**. The following panel is displayed:

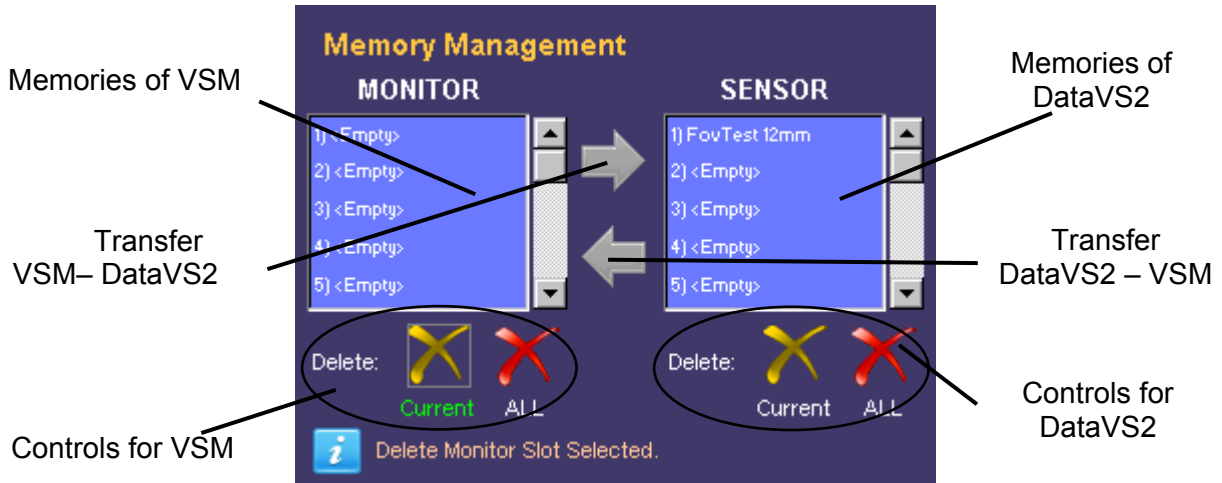

As shown in the figure, the panel is divided in two: a VSM area (concerning the local memory) and a DataVS2 area (remote device memory).

NOTE *If panel is accessed without DataVS2 connection, the sensor area cannot be accessed and the user can operate only on the VSM memory (only cancellations).*

8.3.1 Slot Selection (VSM)

To select a memory slot to use, the focus must be moved on the **“MONITOR”** label using the **ARROWS** and **SET** must be pressed.

Once done, the focus is moved in the list of slots where the user can scroll through the memories only using the **UP/DOWN ARROWS**

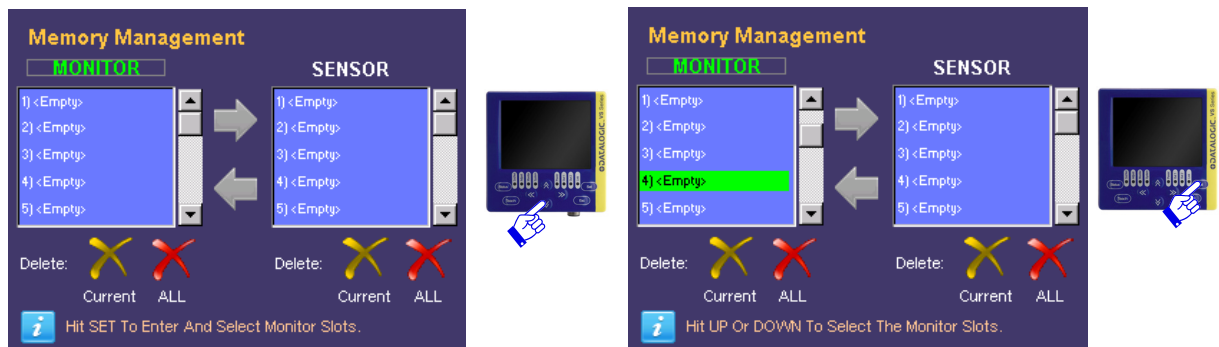

Press **SET** to confirm the slot currently selected.

At this point, the focus returns outside the memory area and allows navigation between the other buttons.

8.3.2 Slot Selection (DataVS2)

The slot selection is similar to the VSM one: the focus must be moved using the **ARROWS** on the “*SENSOR*” label and **SET** must be pressed. The focus will be moved inside the memory list and once chosen the desired one press **SET** to confirm.

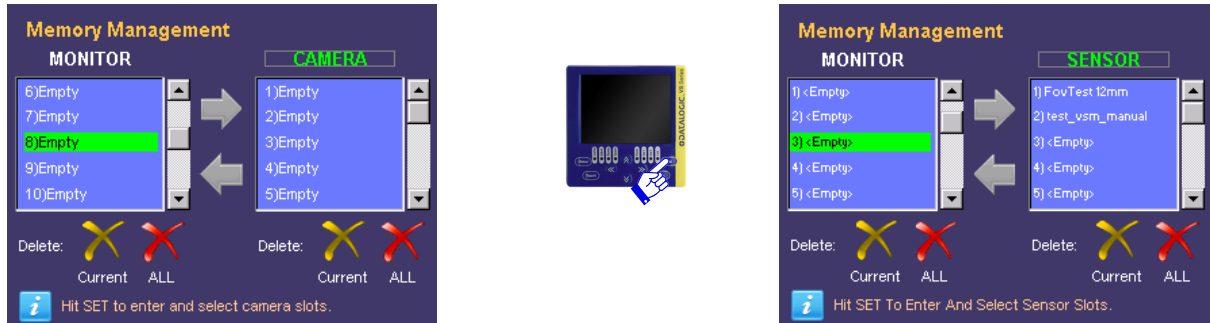

Once selected both memory slots, the transfer operations can be made.

8.3.3 Transfer from VSM to DataVS2

To transfer the memory slot from VSM to DataVS2 (after selecting both the source as well as the destination) move the focus on the “*Arrow on Right*” button and press **SET**.

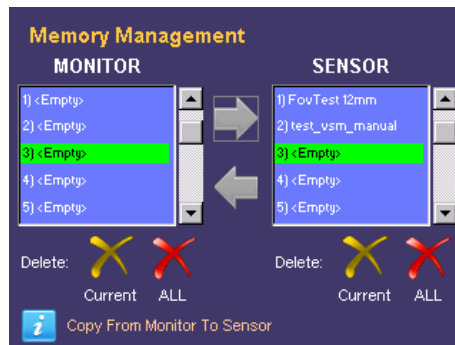

At this point the information label will request another operation confirmation, to proceed press **ARROW UP**, otherwise press **ARROW DOWN** to abandon.

If conformed, the data will be transferred between VSM and DataVS2. As soon as the operation has finished, an information label will display the result and a refresh of the panel names will be made.

8.3.4 Transfer from DataVS2 to VSM

To transfer the memory slot from DataVS2 to VSM (after selecting both the source as well as the destination) move the focus on the “Arrow on Left” button and press **SET**.

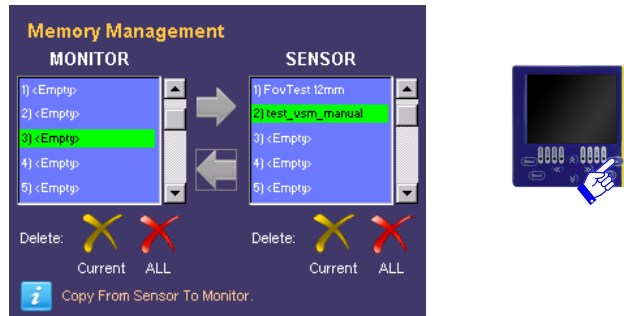

At this point the information label will request another operation confirmation, to proceed press **ARROW UP**, otherwise press **ARROW DOWN** to abandon.

If confirmed, the data will be transferred between VSM and DataVS2. As soon as the operation has finished, an information label will display the result and a refresh of the panel names will be made.

8.3.5 Cancellation of a VSM Slot

First select the desired slot (refer to previous paragraph “Selection of slot (VSM)”). Then move the focus on “Delete Current” button (on the bottom left side of the screen) and press **SET** to confirm:

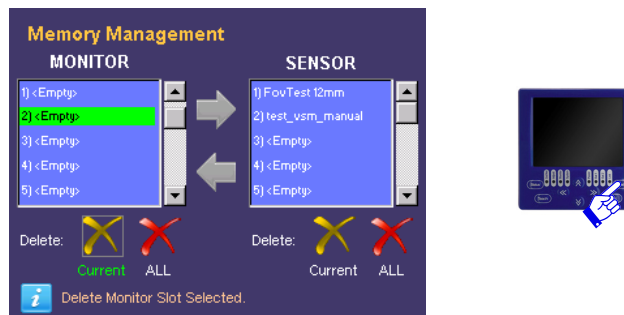

At this point the information label will request another operation confirmation:

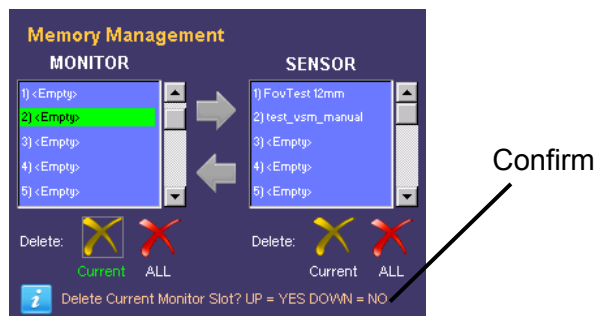

To proceed press **ARROW UP** otherwise, press **ARROW DOWN** to abandon. In both cases, the information label will display the operation result and a refresh of the panel names will be made.

8.3.6 Cancellation of a DataVS2 Slot

Just like the VSM slots, the desired slot has to be selected (refer to previous paragraph “*Selection of slot (DataVS2)*”). Obviously the monitor must be connected to a sensor to access its memory.

Then move the focus on “**Delete Current**” button (on the bottom right side of the screen) and press **SET** to confirm:

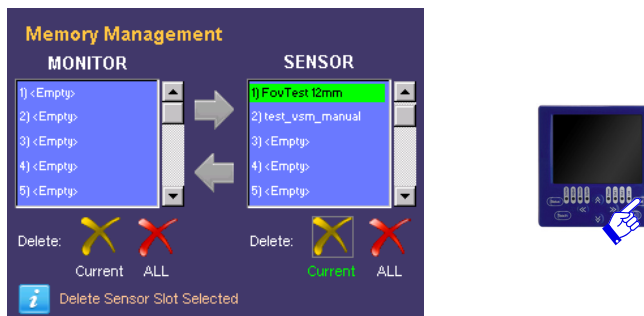

Another operation confirmation is requested also for the DataVS2 slots:

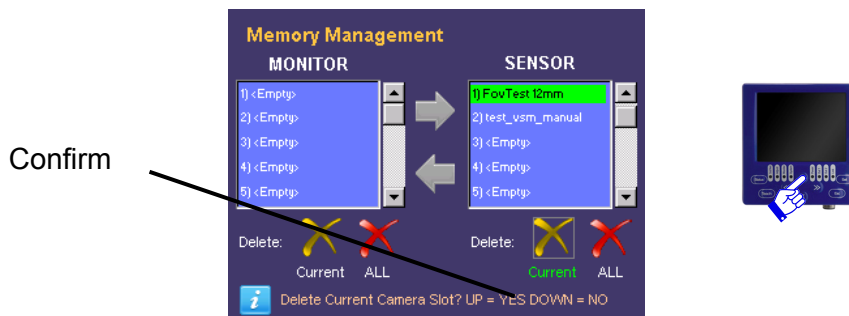

To proceed press **ARROW UP** otherwise, press **ARROW DOWN** to abandon. In both cases, the information label will display the operation result and a refresh of the panel names will be made.

8.3.7 Cancellation of all the VSM Slots

To cancel all the VSM memory slots no specific slot has to be selected but the user must only move the focus on the “**Delete ALL**” icon on the bottom left side of the screen and press **SET**.

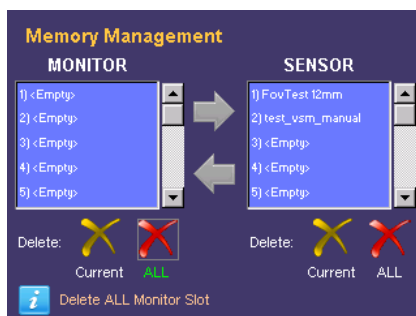

Another confirmation will be requested. To proceed press **ARROW UP** otherwise, press **ARROW DOWN** to abandon. In both cases, the information label will display the operation result and a refresh of the panel names will be made.

8.3.8 Cancellation of all the DataVS2 Slots

To cancel all the DataVS2 memory slots no specific slot has to be selected but the user must only move the focus on the **“Delete ALL”** icon on the bottom right side of the screen and press **SET**.

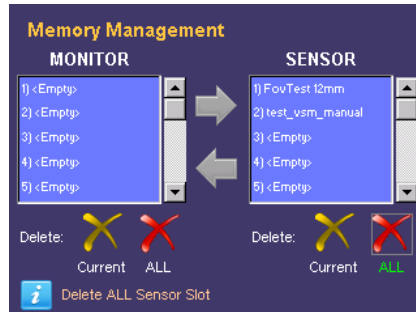

Another confirmation will be requested. To proceed press **ARROW UP** otherwise, press **ARROW DOWN** to abandon. In both cases, the information label will display the operation result and a refresh of the panel names will be made.

8.4 FACTORY RESET

This panel can be accessed only when no DataVS2 are connected and when the factory reset of the VSM has to be restored.

All the memory slots are going to be cancelled, the network parameters changed and passwords cancelled.





The system reset requires the VSM restart and the loss of all the data stored in the memory.

NOTE

8.5 SENSOR LIST

The “Sensor List” panel, after having made a discovery, lists the DataVS2 present in the subnet.

To connect a sensor the user just has to select it from the list with the **UP/DOWN ARROWS** and press **SET**.

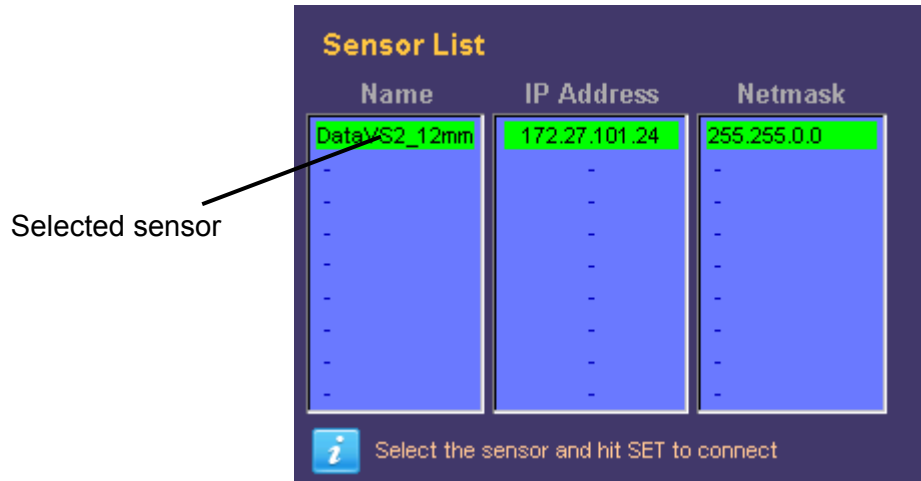

Once the connection has been established, the VSM returns immediately to the monitor mode.

8.6 USERS

This panel allows the user to set a password to protect the system. This protects the sensor against accidental or unauthorised modifications. In the factory setting the password is disabled for all accounts.

Firstly, the operation to effect on the profiles must be selected: “Selection” or “Modify” and then press **SET**.

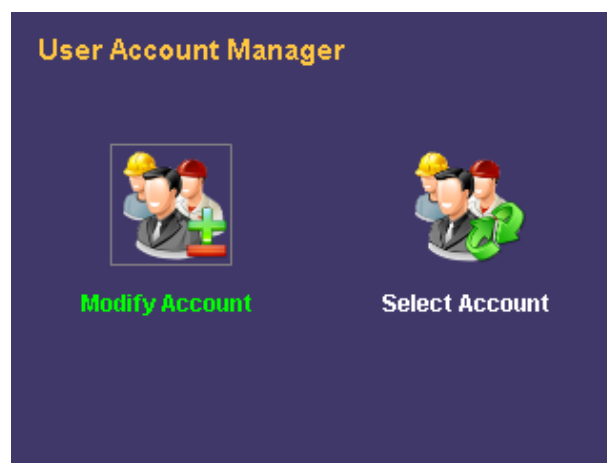

The account selection panel is displayed as follows:

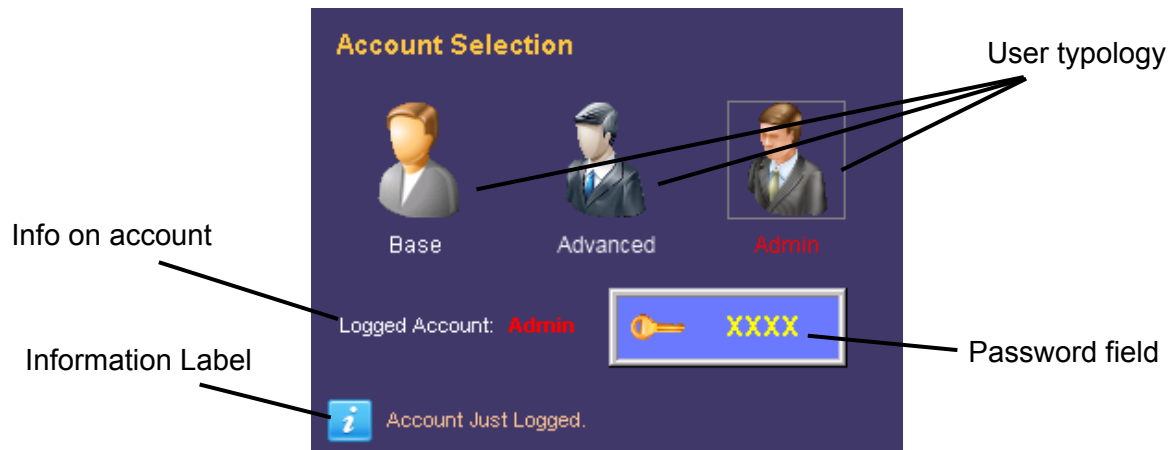

NOTE  Each user logs in using the administrator account until a new password is memorised.

To enable the administrator password, the user must access **“Modify Account”**, select **“Admin”** and press **SET**.

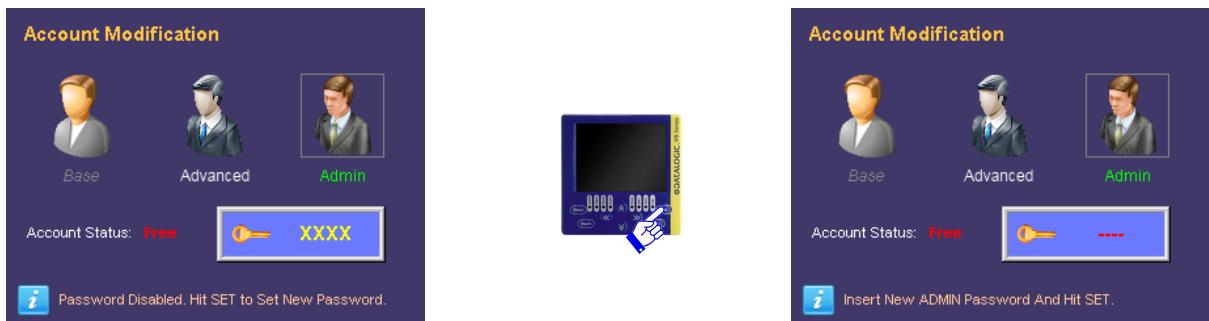

The user can now digit a new password made up of a sequence of four keyboard buttons (**ARROW UP/DOWN/RIGHT/LEFT**).



Once the password has been entered, press **SET** to confirm. The password will be saved and each time the user wants to login as administrator, the **“Admin”** account must be selected and the password entered.



NOTE

When the administrator password has been forgotten, the VSM can be unblocked with the recovery password **ARROW UP, ARROW LEFT, ARROW RIGHT, ARROW RIGHT**. At the end of the procedure remember to cancel the old password and set a new one in the **“Modify Account”** panel.

By selecting the **“Base”** user, the majority of the advanced functions of the VSM cannot be accessed.

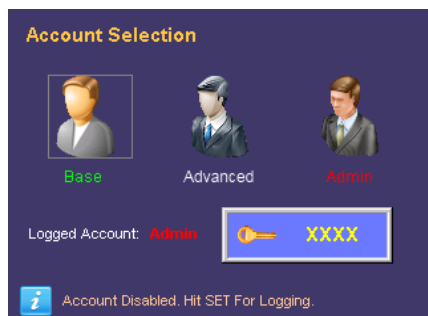

Only the **“Sensor List”** panel can be displayed, as well as the sensor to select for connection and the visualisation in **“Monitor”** during inspection execution.

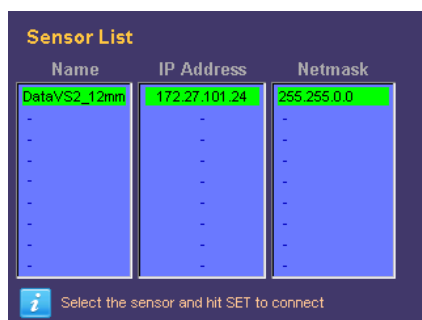

NOTE

After a **“Factory Reset”**, all the passwords are cancelled and the administrator account is restored as default.



NOTE

The **“Advanced”** account can be activated only after activating the **“Admin”** account.

To select the **“Advanced”** user, the administrator account has to be first activated.

In **“Modify Account”** mode the user has to select **“Advanced”** and then save a password.

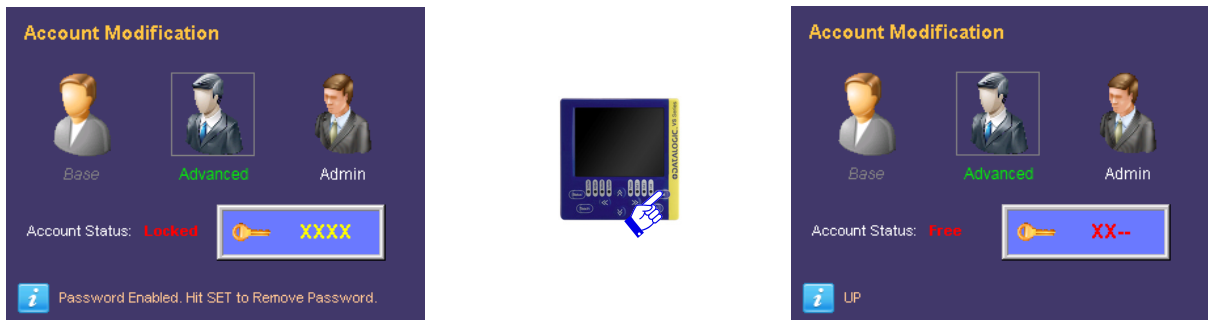

After this, the account will be active and only a part of the advanced functions enabled.

Besides the basic rights, the inspection can be changed and the parameters of the relative tools modified.



USER RIGHTS	
Account	Main Functions
<i>Base</i>	This user can only view the current status of the inspection (“Monitor” mode) and cannot access any of the advanced functions panels.
<i>Advanced</i>	This user can be selected only after the administrator account has enabled the profile. Has limited rights and can monitor the status of the current inspection, change it and modify tool parameters.
<i>Admin</i>	(User enabled by default when no password is set and after every “Factory Reset”). This user controls completely the device, can manage all controls, scroll through all the panels and can create and/or cancel other users.

8.6.1 Removal of the Password

To disable all the accounts and remove the administrator password, the user must log in as **“Admin”**.

Access **“Modify Account”**, select **“Admin”** user and press **SET**.



At this point the system requests the user to confirm the cancellation of the password. To confirm press **ARROW UP**.

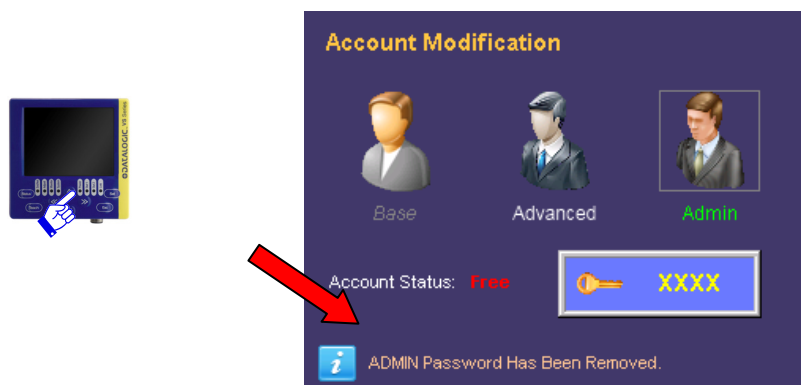

8.7 LANGUAGE

Through this panel you can change the language of the VSM, current language is written in the upper right side of screen. To set up a new language, choose the one you want with the **RIGHT/LEFT ARROW** and press **SET**.



8.8 DISCONNECT

The **“Disconnect”** icon is displayed on the **“System”** panel only when connected to a DataVs2. This indicates that the sensor is still connected and allows the user to disconnect from the device.

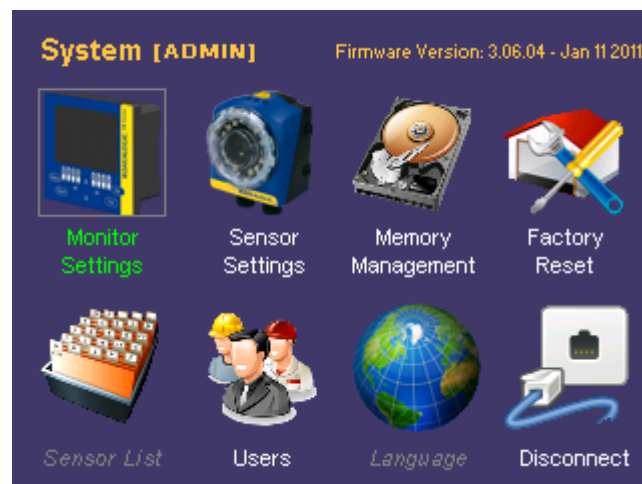

NOTE

*If the sensor is connected the **“Sensor List”** and **“Factory Reset”** panels cannot be accessed.*

If disconnected, to reconnect a DataVS2 or another device, the user must access the **“Sensor List”** panel and select it from the list.

9 DATAVS2 GUI CONNECTION

To connect the VSM to DataVS2 GUI the “On Line” mode must be selected from the specific interface.

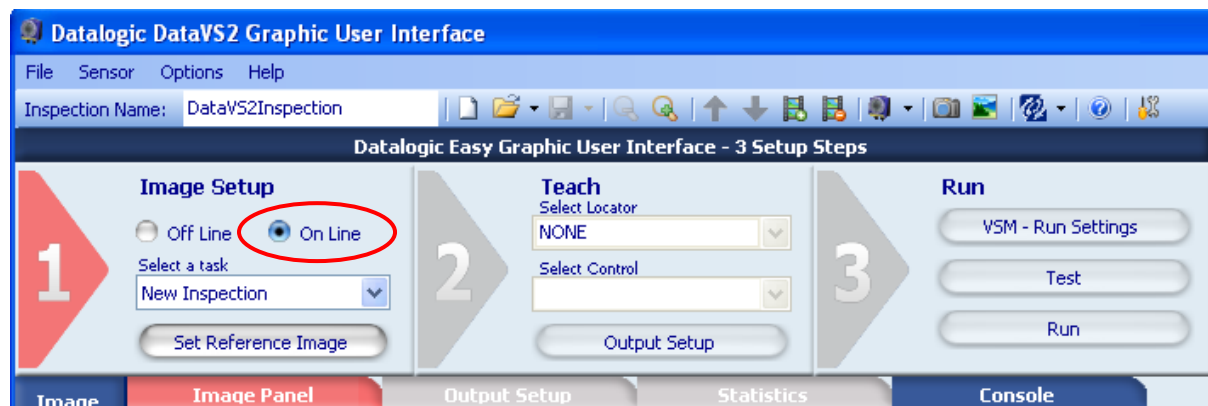

After having selected the relative radio button, the following screen will appear:

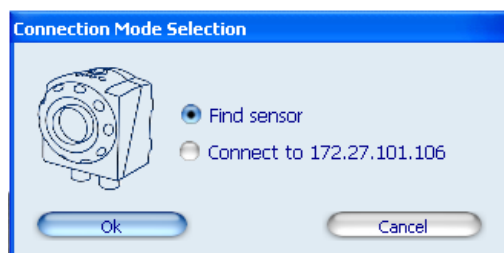

Parameters:	Description
<i>Find sensor</i>	DataVS2 GUI searches for all the connected sensors/monitors and lists them in the CONTROL PANEL
<i>Connect to ...</i>	DataVS2 GUI will connect the sensor/monitor whose address corresponds to the IP address displayed

If “Find sensor” has been selected, the software will initially show a window with a progress bar and, if any devices are connected, it will show this screen in the Control Panel present on the right side of the main window:

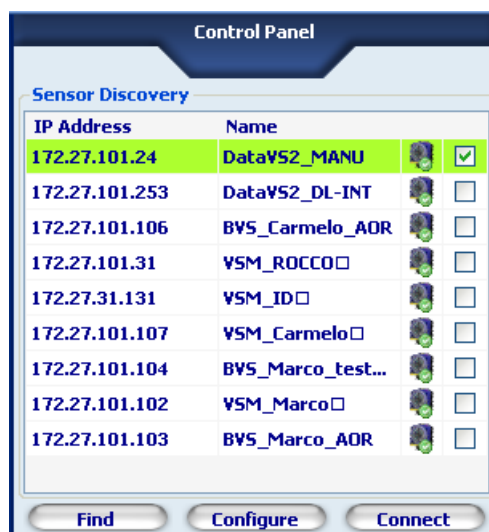

The control panel will display a list of all the DataVS2/VSMs found by the “Find sensor” function. The following information will be shown for each device:

- The IP address;
- The name;
- An indication on the possibility of creating a connection (line highlighted in green) or not (line highlighted in red);
- A check box to select the DataVS2/VSM to reach.

**NOTE**

If the line relevant to the desired device is highlighted in red, the connection cannot be established. In this case we suggest to check the IP address and Subnet Mask

To connect, check the box relative to the VSM and click on Connect. If connection is successful the DataVS2 GUI will display the “VSM setting” panel.

9.1 VSM GENERAL INFORMATION

The screenshot shows the 'VSM Settings' window with the following details:

- General Info & VSM Network Settings** (selected tab)
- General Info**
 - HW revision: 0
 - FW version: VSM.1.00.00
 - Model Type: VSM
- Current Configuration**
 - VSM Name: VSM
 - MAC Address: 00:50:C2:32:3C:E1
 - IP Address: 172.27.101.113
 - Subnet Mask: 255.255.0.0
- Desired Configuration**
 - VSM Name: VSM (20 characters at most)
 - IP Address: 172.27.31.130
 - Subnet Mask: 255.255.0.0
 - Suggested IP button
- Buttons:** Apply, Close
- Warning:** WARNING: closing window, connection will be dropped down.

This window displays general information on VSM to which you are connected. Of the parameters displayed, you can change:

- the name of the VSM
- IP address
- Subnet Mask

After defining the new values, if you want to confirm those changes, you must click the Apply button.

9.2 VSM MEMORY SETTINGS

This window shows the memory status of the VSM to which you are connected. It also allows you to save on VSM PC inspections by pressing the button "Save On VSM";

To save on PC the inspections saved on the memory of VSM by pressing the button "Save On PC";

To cancel inspections of VSM by pressing the button "Delete".

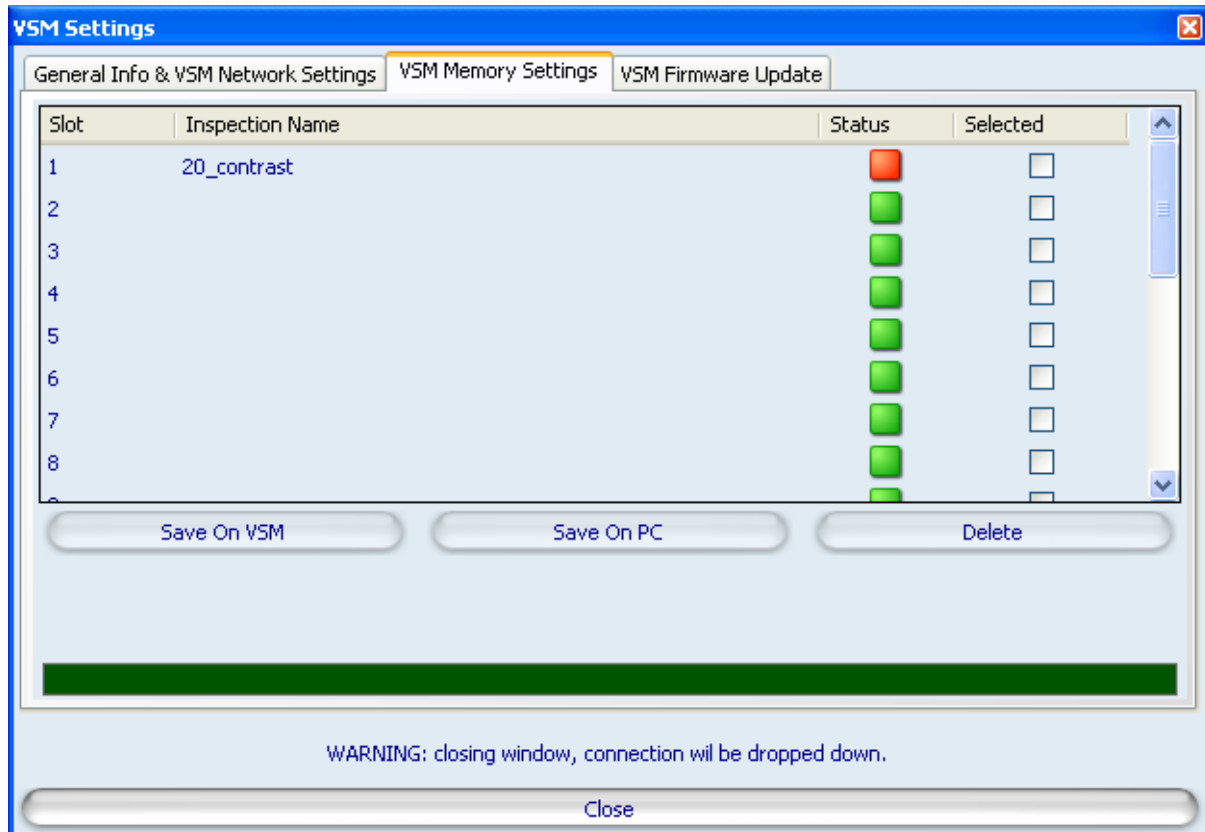

9.3 FIRMWARE UPDATE

The “VSM firmware updating” section can be accessed from the “VSM setting” panel and is displayed as follows:

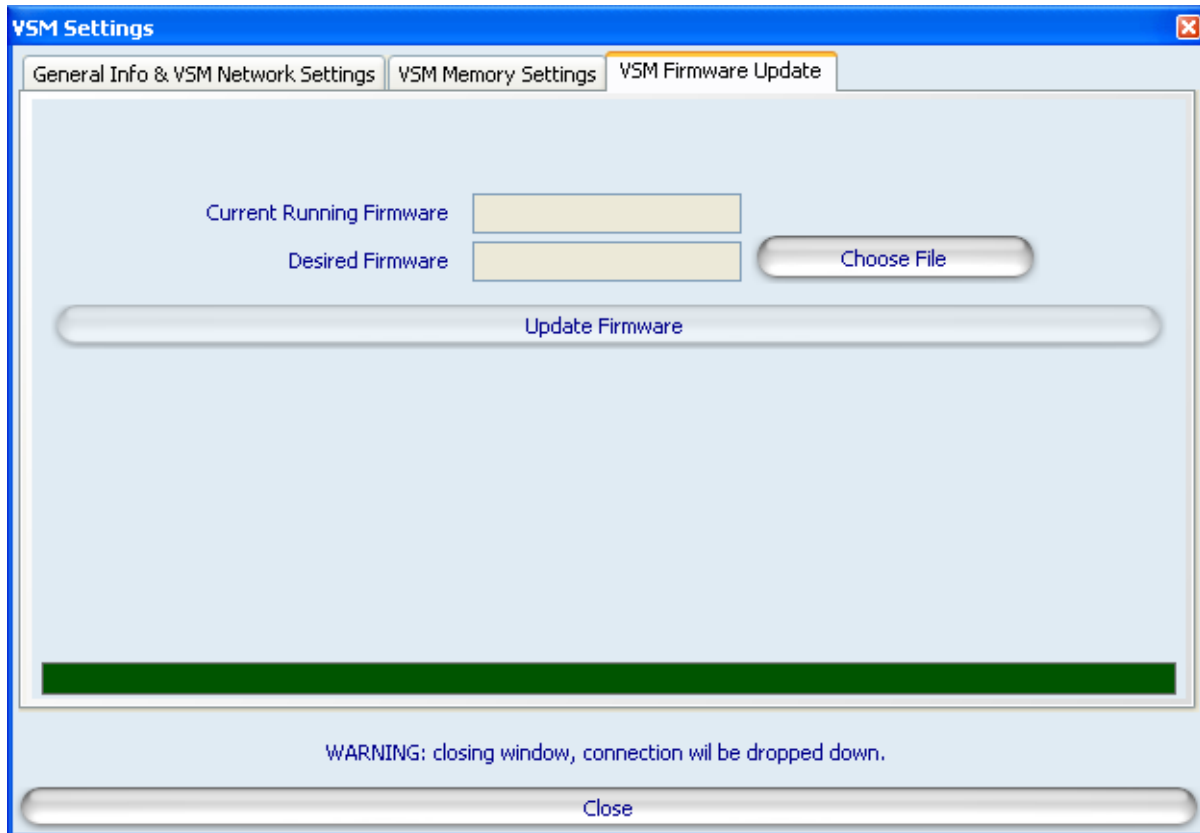

Parameters:	Description
<i>Current Firmware</i>	Version of Firmware currently executed on the connected VSM.
<i>Choose File</i>	Press this button to select the Firmware file to be loaded on the sensor. A dialogue window will then allow the user to choose the “Desired Firmware” file saved in the PC. After selecting the desired firmware and pressing “OK” in the dialogue window, the firmware version selected will be displayed in the “Desired Firmware” field.
<i>Update Firmware</i>	<p>Press this button to update firmware in execution on the connected VSM.</p> <p>Two types of firmware updates are possible:</p> <ul style="list-style-type: none"> • firmware upgrade: more recent firmware version, with respect to the one currently in execution, is loaded on the VSM; • firmware downgrade: a less recent firmware version, with respect to the one currently in execution, is loaded on the VSM. <p>Note: if this button is disabled, the selected firmware cannot be loaded on the connected VSM due to Hardware version incompatibility. In this case please select a different firmware.</p> <p>Note: after having updated the VSM firmware, the DataVS2 GUI will disconnect from the device and the VSM has to be restarted.</p> <p>Warning !! never power Down the VSM during Firmware update procedure. The Monitor will restart by self at the end of the update sequence.</p>

10 CHECKS AND PERIODIC MAINTENANCE

Correct system maintenance is necessary to remove dust or foreign objects from the VSM display.

Remove dust using a soft cloth, if necessary dampened with a neutral detergent solution.

Avoid using:

- detergents which contain alcohol or solvents
- wool or synthetic cloths

Refer to the Datalogic Automation website (www.automation.datalogic.com) to verify the availability of new firmware updates. To check the firmware version and date on your system, please refer to the System → Monitor Settings menu.

11 WARRANTY

The product you purchased is warranted to be free from manufacturing defects for a period of 36 (thirty-six) months from date of manufacture.

Warranty does not cover damage and defects resulting from improper use of the sensor or accidental damage due to shock or in the event the product is dropped.

The sensor contains cutting-edge electronic components that cannot be repaired or replaced by the final user. Do not dismantle the device or make any changes to its components or the warranty will become null and void.

Datalogic may not be held liable for damage to persons or property resulting from failure to comply with the provisions reported herein.

In case of problems, contact DATALOGIC AUTOMATION Service Department.

Service Department

Phone no.: +39 051 6765611

Fax no.: +39 051 6759324

12 SPECIFICATIONS

Item	Description
Supply voltage:	24 Vdc \pm 10%
Ripple voltage:	2.4 Vpp max.
Current draw:	Max 150 mA @ 24Vdc max
Dimensions:	96 x 96 x 39 mm
Indicators:	8 LEDs + 3.5" colour LCD monitor
Setup:	DataVS2 GUI
Data retention:	Non volatile FLASH memory
Operating temperature:	-10 °C ... +55 °C
Storage temperature:	-20 °C ... +70 °C
Vibrations: (EN60068-2-6)	14 mm @ 2 to 10 Hz; 1.5 mm @ 13 to 55 Hz; 2 g @ 70 to 200 Hz; 2 hours on each axis
Shock resistance: (EN60068-2-27)	11 ms (30 G) 6 shocks on each axis
Housing material:	ABS
Mechanical protection:	IP20 (IP40 when panel mounted)
Connections:	2 x M12 4 poles
Weight:	180 g

13 OVERALL DIMENSIONS

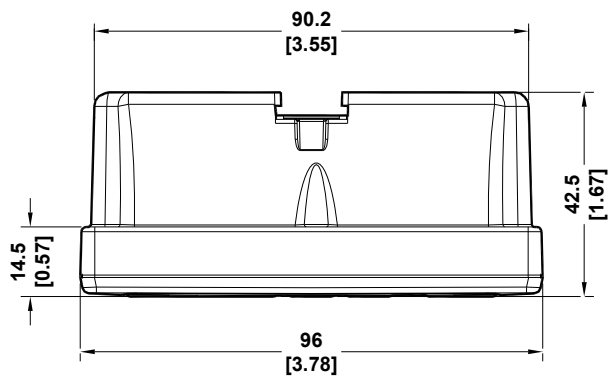
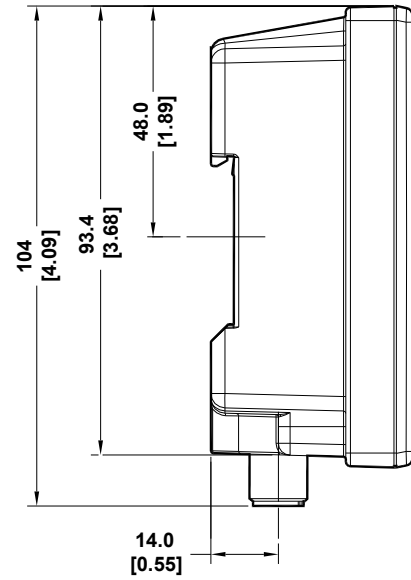
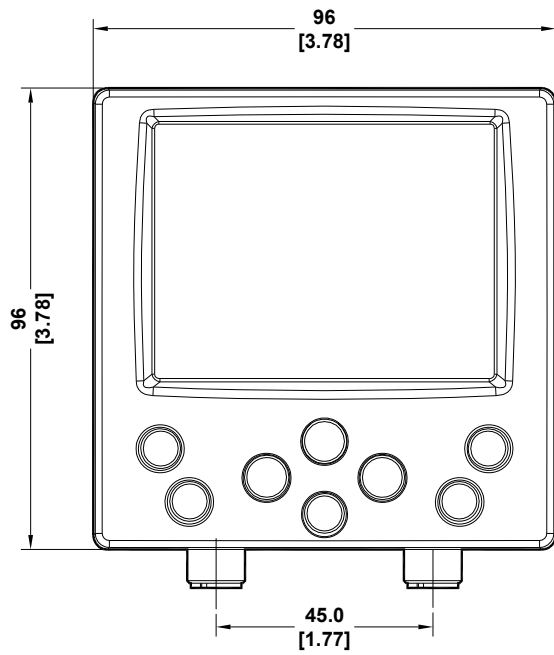

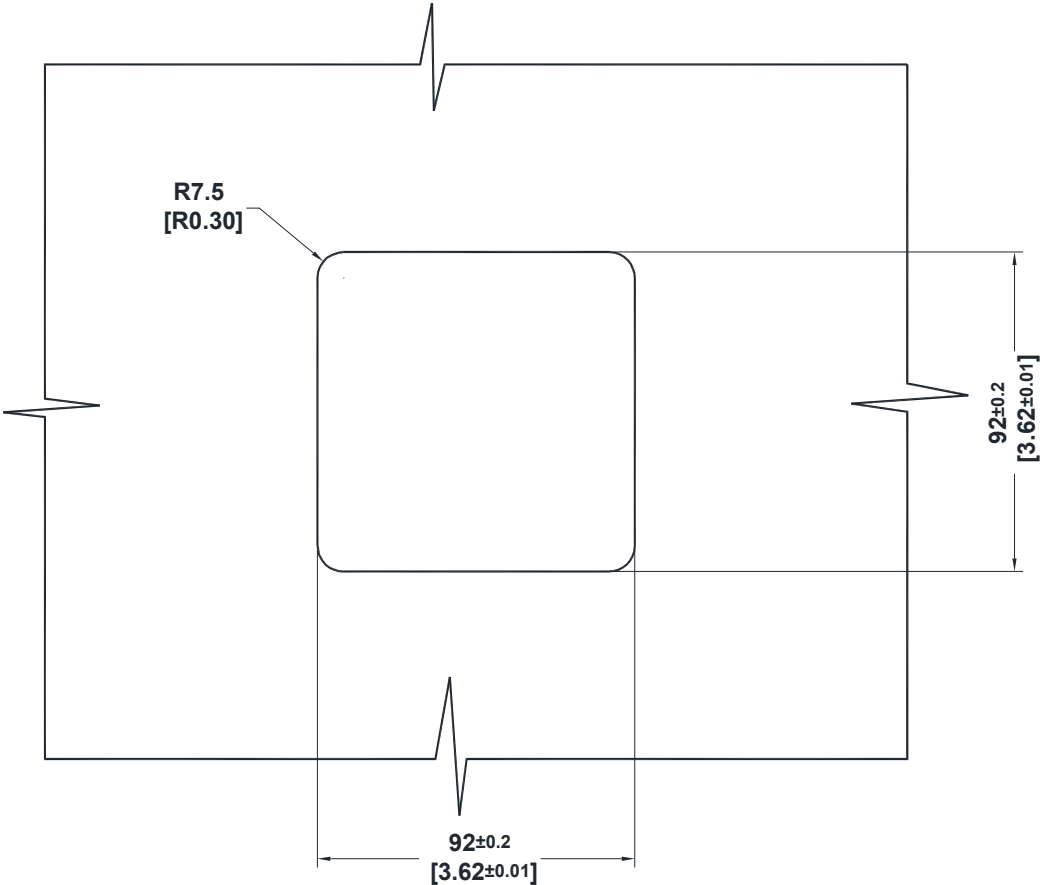

**Datalogic Automation S.r.l.**

Via Lavino 265

40050 Monte San Pietro

Bologna - Italy

www.automation.datalogic.com*declares that the***DATAVS2 ; SMART CAMERA SENSOR****VSM ; VISION SENSOR MONITOR FOR DATAVS2***and all its models**are in conformity with the requirements of the European Council Directives listed below:***2004 / 108 / EC EMC Directive***This Declaration is based upon compliance of the products to the following standards:***EN 60947-5-2, Ed.3 DECEMBER 2007:***LOW-VOLTAGE SWITCHGEAR AND CONTROLGEAR.
PART 5: CONTROL CIRCUIT DEVICES AND SWITCHING.
SECTION 2: PROXIMITY SWITCHES**PRODUCT STANDARD IS IDENTICAL TO: IEC 60947-5-2, OCTOBER 2007***EN 61000-6-2, SEPTEMBER 2005:***ELECTROMAGNETIC COMPATIBILITY (EMC)**PART 6-2: GENERIC STANDARDS - IMMUNITY FOR INDUSTRIAL ENVIRONMENTS***EN 55011 (CLASS A ISM), MARCH 2007:***INDUSTRIAL, SCIENTIFIC AND MEDICAL (ISM) RADIO-FREQUENCY EQUIPMENT -
ELECTROMAGNETIC DISTURBANCE CHARACTERISTICS - LIMITS AND METHODS
OF MEASUREMENT*

Monte San Pietro, March 7th, 2011

Lorenzo Girotti
Product & Process Quality Manager