

## M12 CYLINDRICAL INDUCTIVE SENSORS

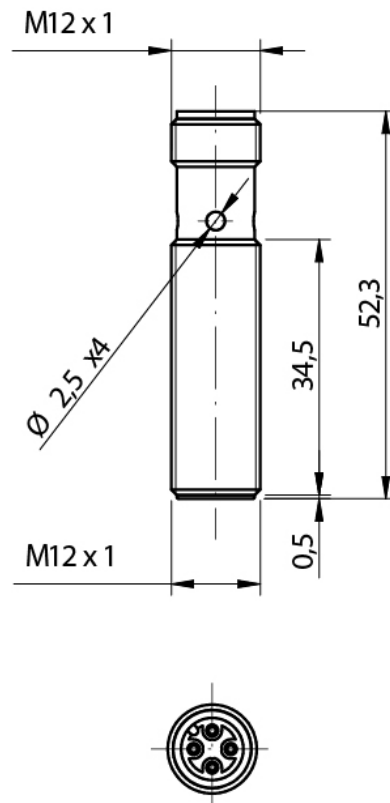

- Wide range of models: standard, short body, long distance
- Output: cable, M12 and M8 plug cable exit
- Models with 2, 3 wires
- ATEX models, cat. 3, available on request



Indicative image



### Detection properties

Nominal sensing distance	2mm
Operating distance	0...1,62mm
Standard target	12x12mm FE360
Correction Factor	copper: 0,22 / aluminium: 0,31 / brass: 0,41 / stainless steel: 0,77
Thermal drift of Sr	< 10%
Repeat Accuracy	< 5% (UB 24V Ta=23°C ±5°C)
Hysteresis	1 ... 20%

### Application

Description	M12 short case flush mount
-------------	----------------------------

Functions

Proximity

## Outputs

Output type	PNP
Output Function	NO
Switching frequency	2kHz

## Electrical data

Operating Voltage	10...30Vdc
No-Load supply current	≤ 10mA
Load current	≤ 200mA
Leakage current	≤ 10μA
Output voltage drop	≤ 1,8V @200mA
Max ripple content	≤ 10%
LED indicators	Yellow LED output state
Time delay before availability	≤ 50ms
Short-circuit protection	Yes
Reverse Polarity Protection	Yes
Impulsive Overvoltage Protection	Yes
Protection against inductive loads	Yes

## Mechanical data

Mounting	Shielded
Dimensions	M12 x 1 / L = 52,3mm
Weight	20g
Housing Material	Nickel-plated brass
Connections	M12 Plug
Active Head Material	PBT
Tightening torque	10Nm
Operating temperature	-25°C...+70°C
Material	Nickel-plated brass
Diameter/Dimension	M12

## Test/Approvals

Approvals	CE UR
EMC compatibility	IEC 60947-5-2
Shocks and vibrations	Vibration IEC 60068-2-6 / Shock IEC 60068-2-27
Degree of protection	IP67

## Accessories

Supplied Accessories	2 nuts M12x1
----------------------	--------------

## Generical Data

Dimensions	M12 x 1 / L = 52,3mm
Operating Temperature	-25°C...+70°C
Mechanical Protection	IP67

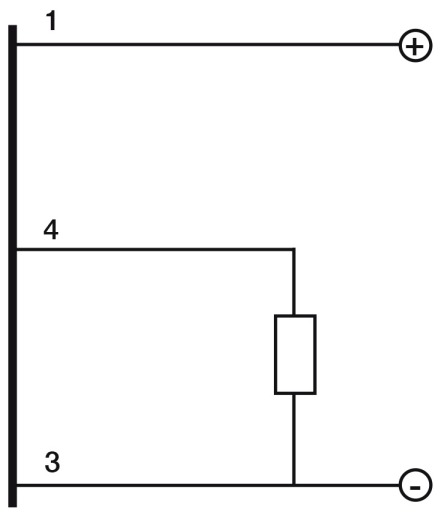

INSTALLATION

---

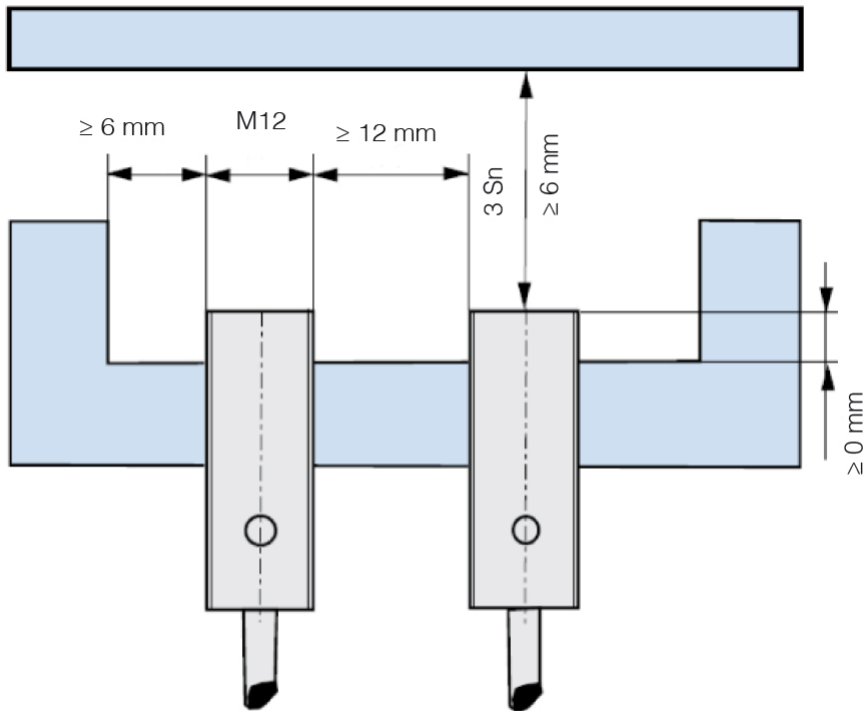

RESPONSE CURVES

---

Parallel offset

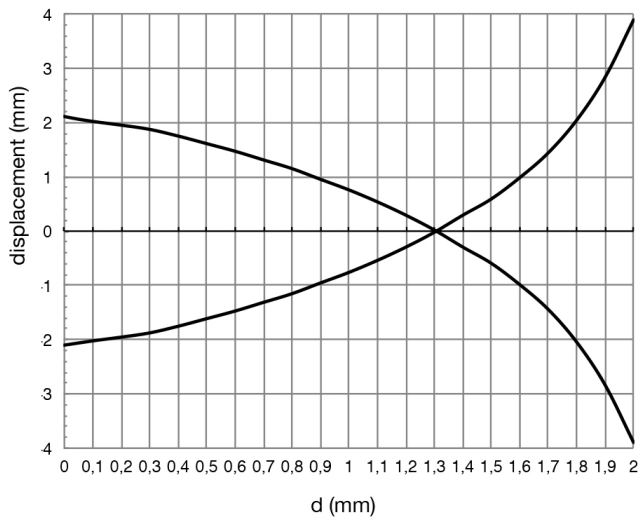

---

**Datasensing S.r.l.**

Strada S.Caterina, 235

41122 Modena (MO)

Tel. 059 420411

Fax 059 253973

E-mail [info@datasensing.com](mailto:info@datasensing.com)

**date of printing**

17/01/2024 09:27:53