

PROPRIETARY STATEMENT: THIS DOCUMENT CONTAINS CONFIDENTIAL AND PROPRIETARY INFORMATION AND IS NOT TO BE REPRODUCED OR DISCLOSED TO OTHERS WITHOUT THE WRITTEN CONSENT OF WANNER ENGINEERING, INC.	UNLESS OTHERWISE SPECIFIED: -DIMENSIONS ARE IN INCHES -INTERPRET DRAWING PER ASME Y14.5-2009 -DIMENSIONS ARE AFTER PLATING, COATING AND HEAT TREATING, BUT BEFORE PAINTING. -REMOVE ALL BURRS AND SHARP CORNERS.	TOLERANCES: X = ± .1 XX = ± .02 XXX = ± .005 ANGLES = ± 1° FINISH: 125/	DWN DMH DATE 10/19/16	WANNER ENGINEERING, INC. 1204 CHESTNUT AVENUE MINNEAPOLIS, MN 55403
			THIRD ANGLE PROJECTION	
DO NOT SCALE DRAWING			DWG NO	SIZE D
SCALE: 1:8 SHEET 1 OF 4			Q155-M	REV A

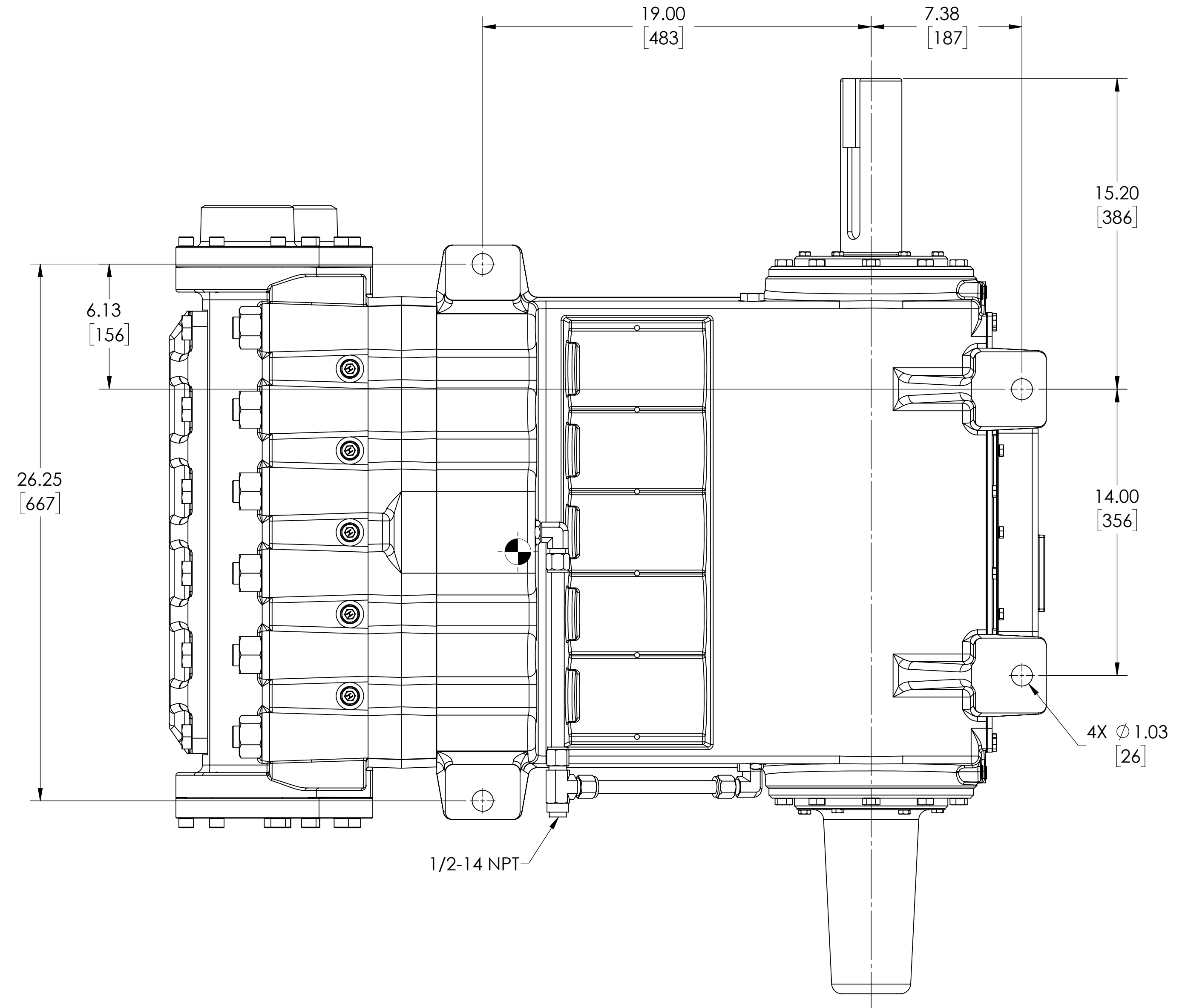

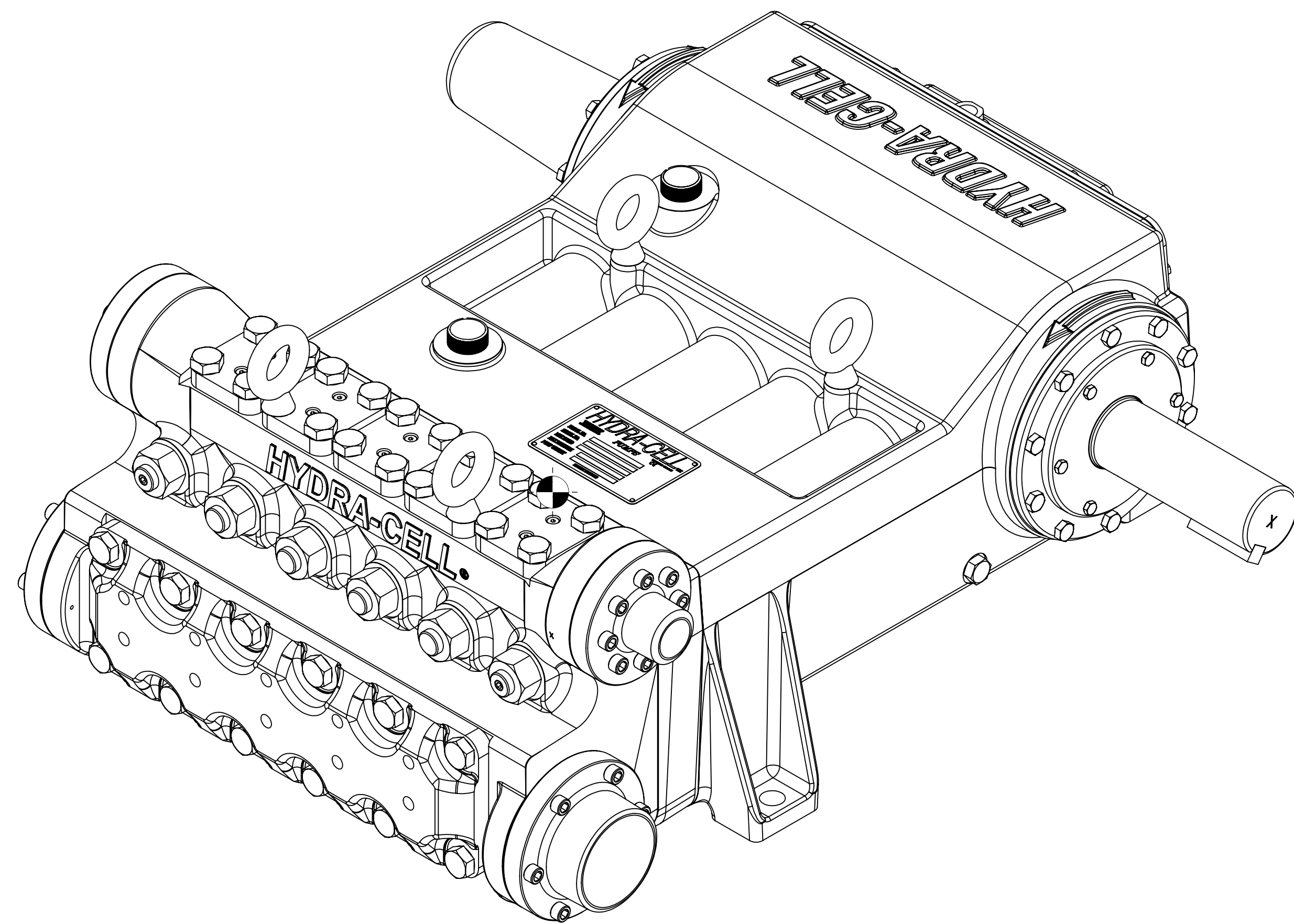

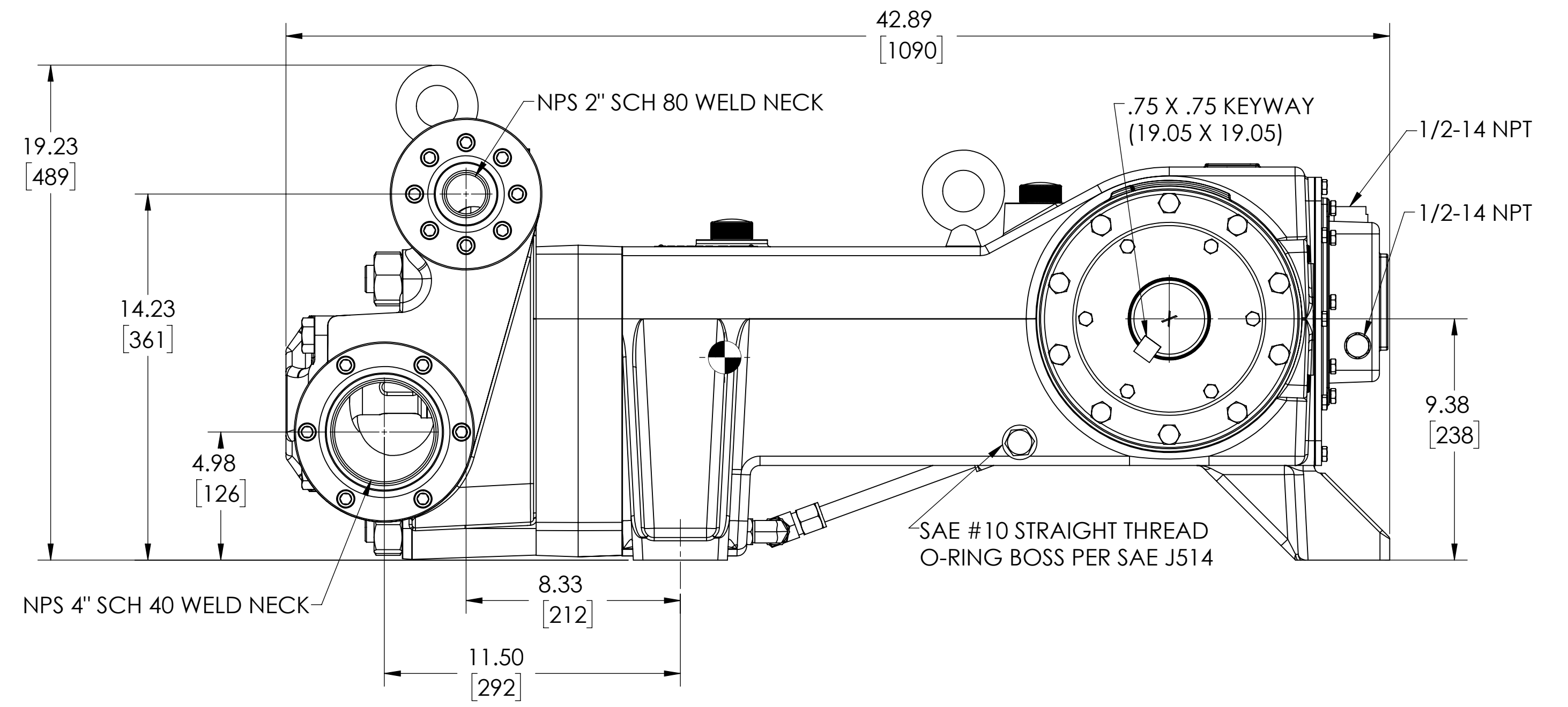
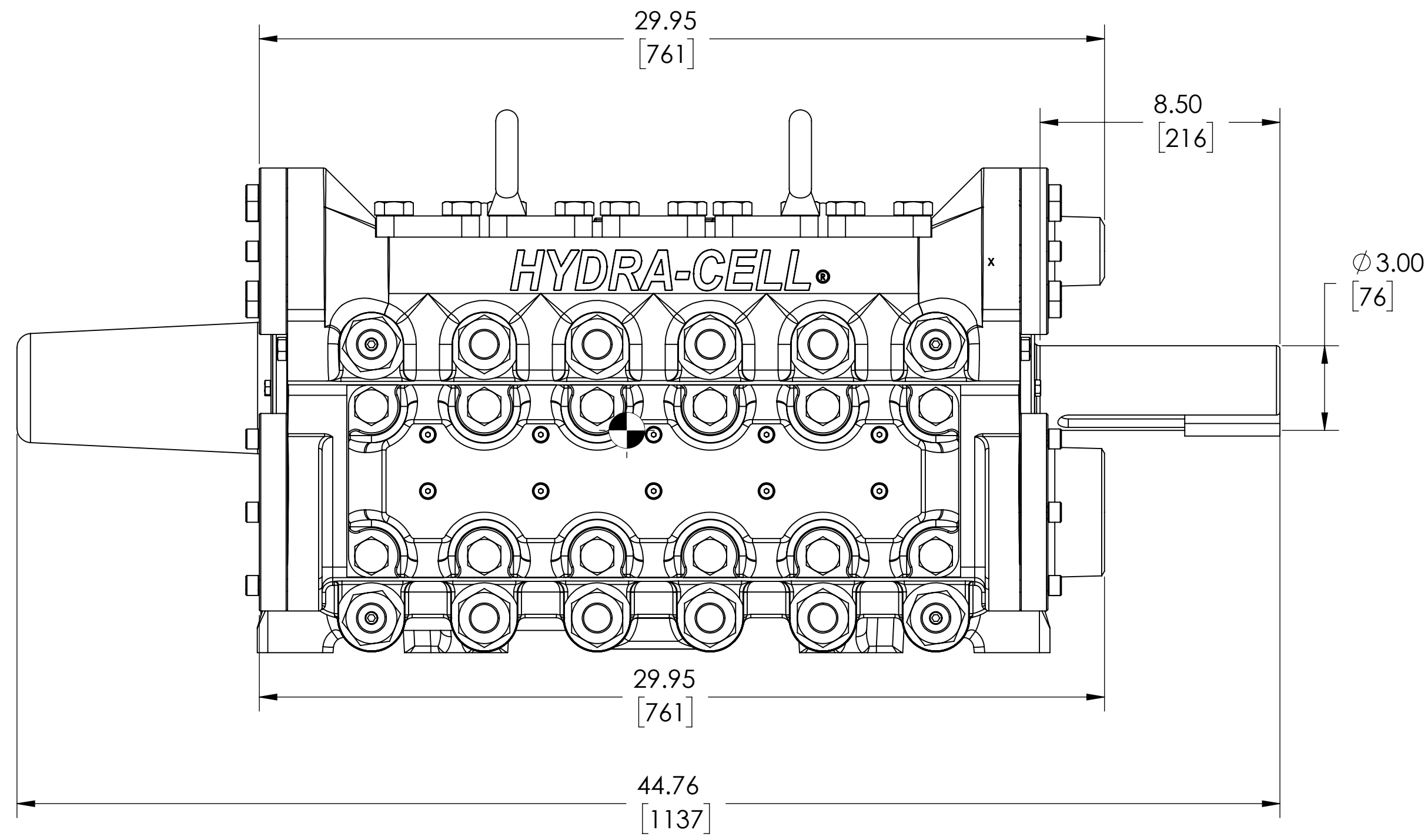
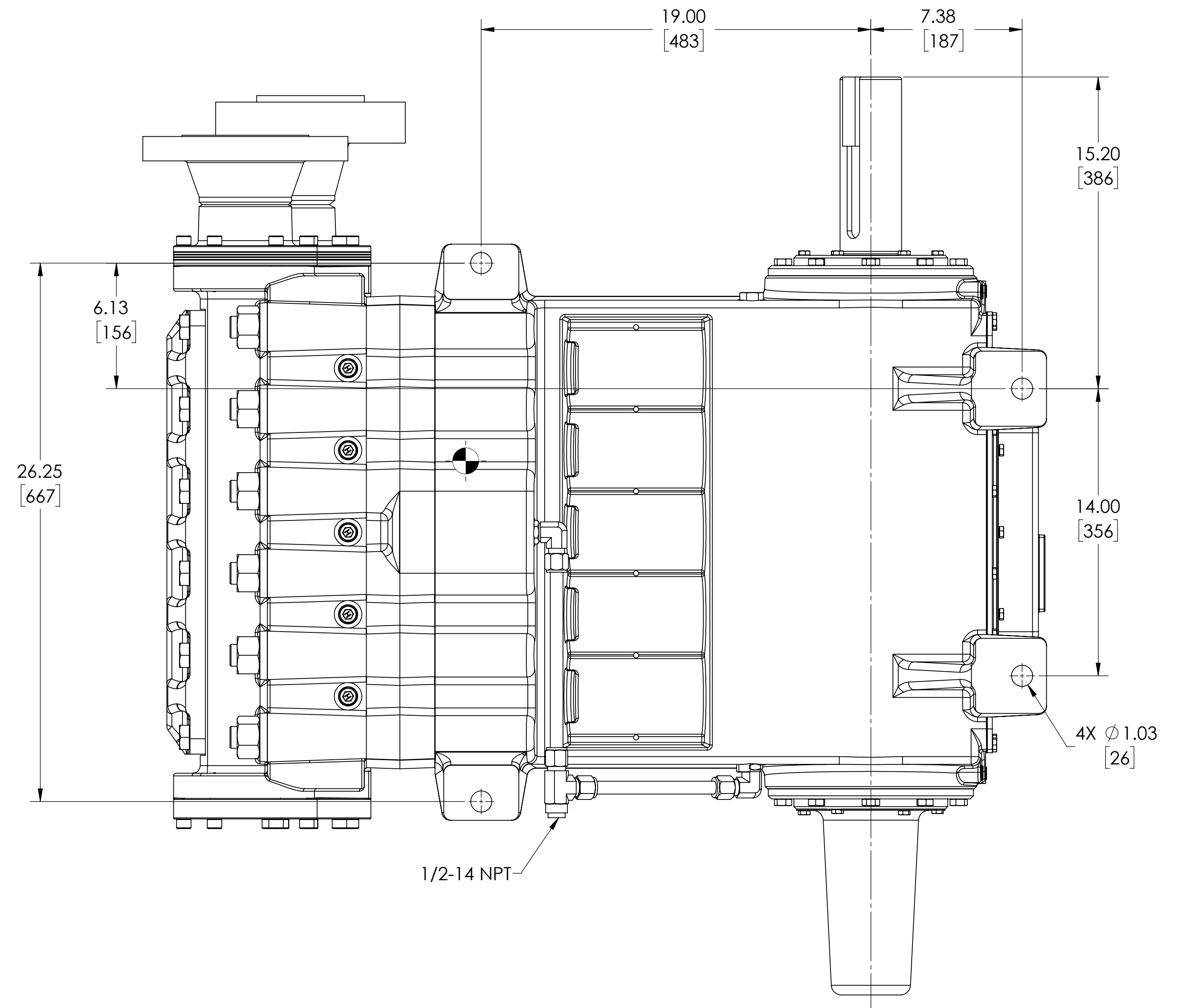
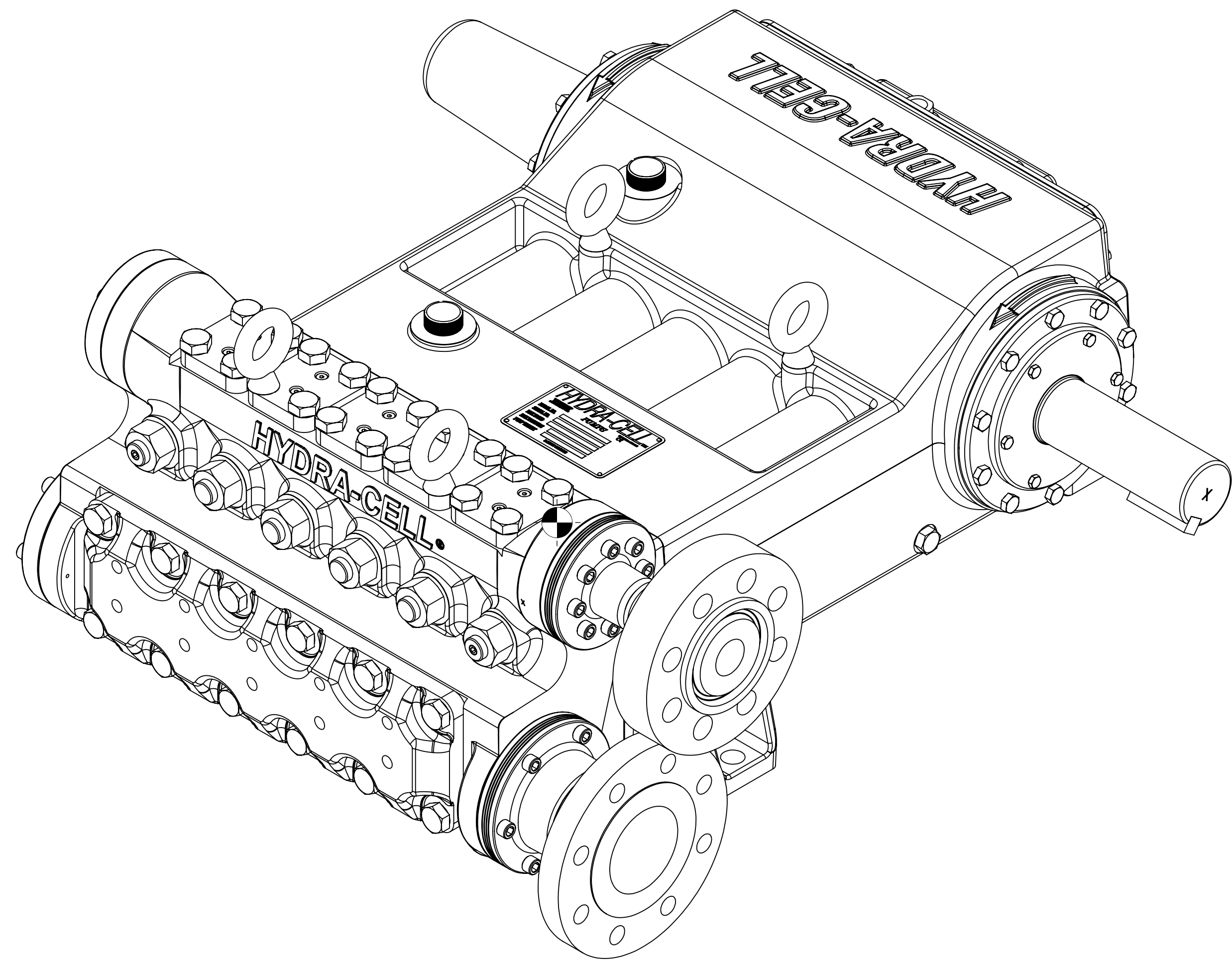
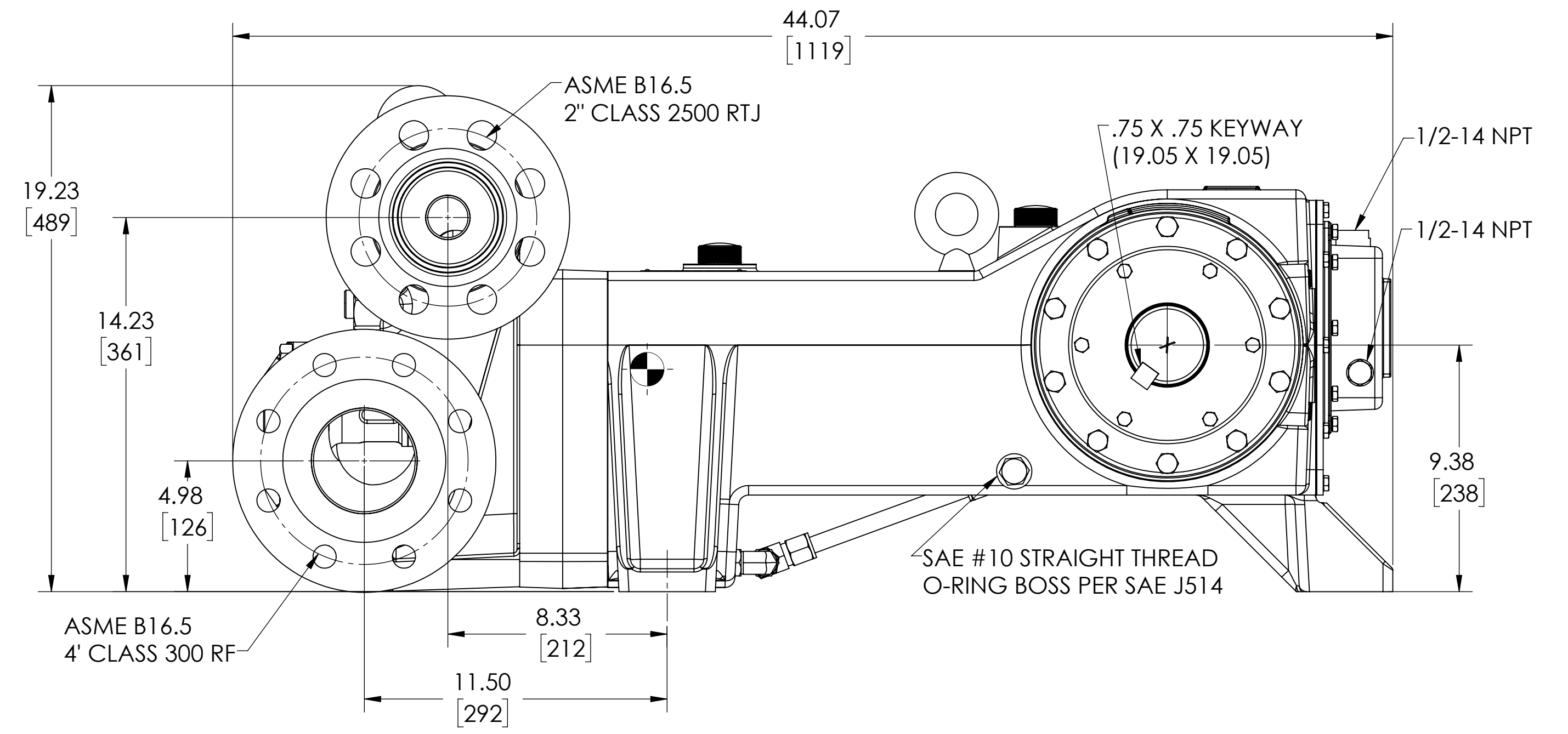
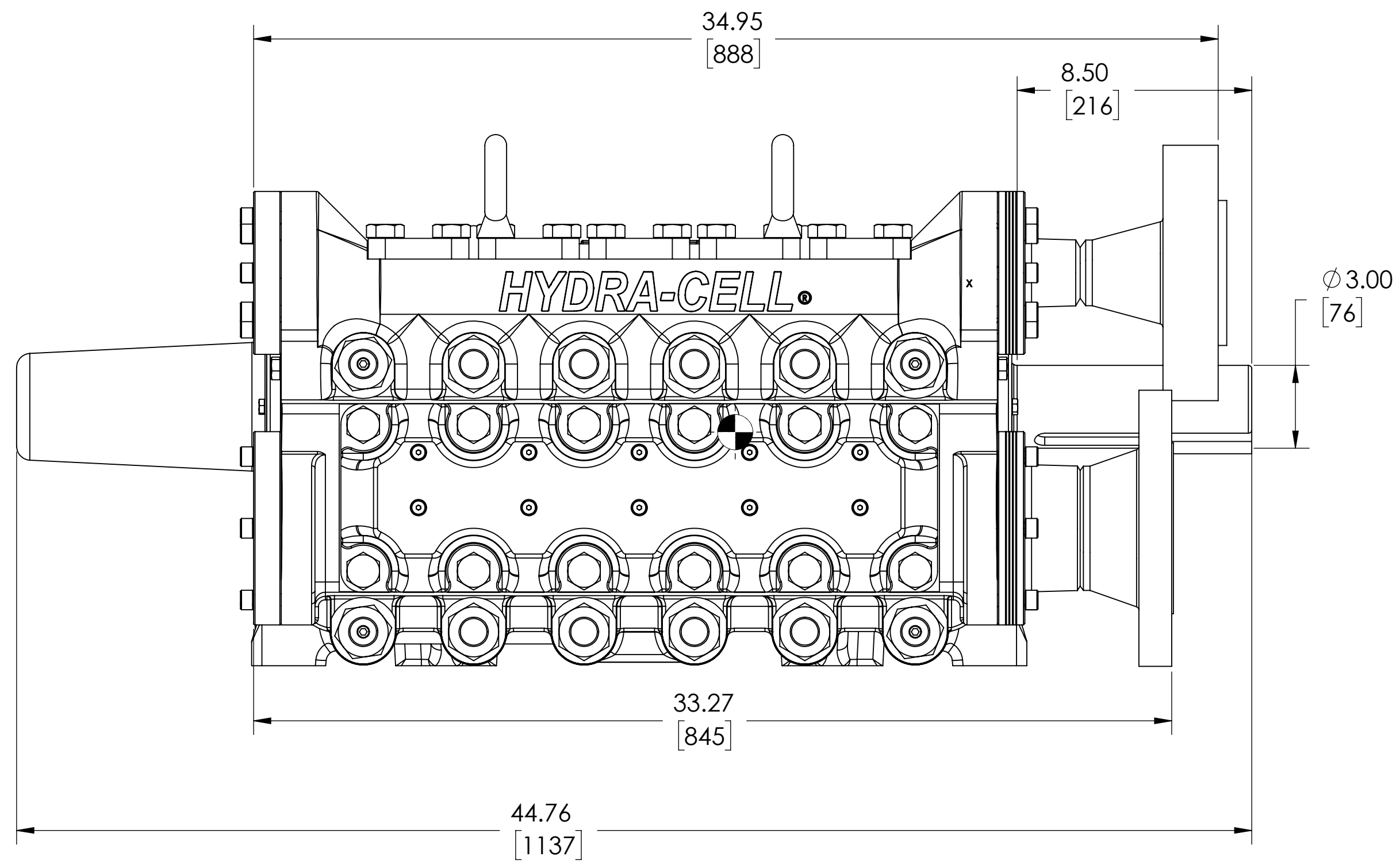
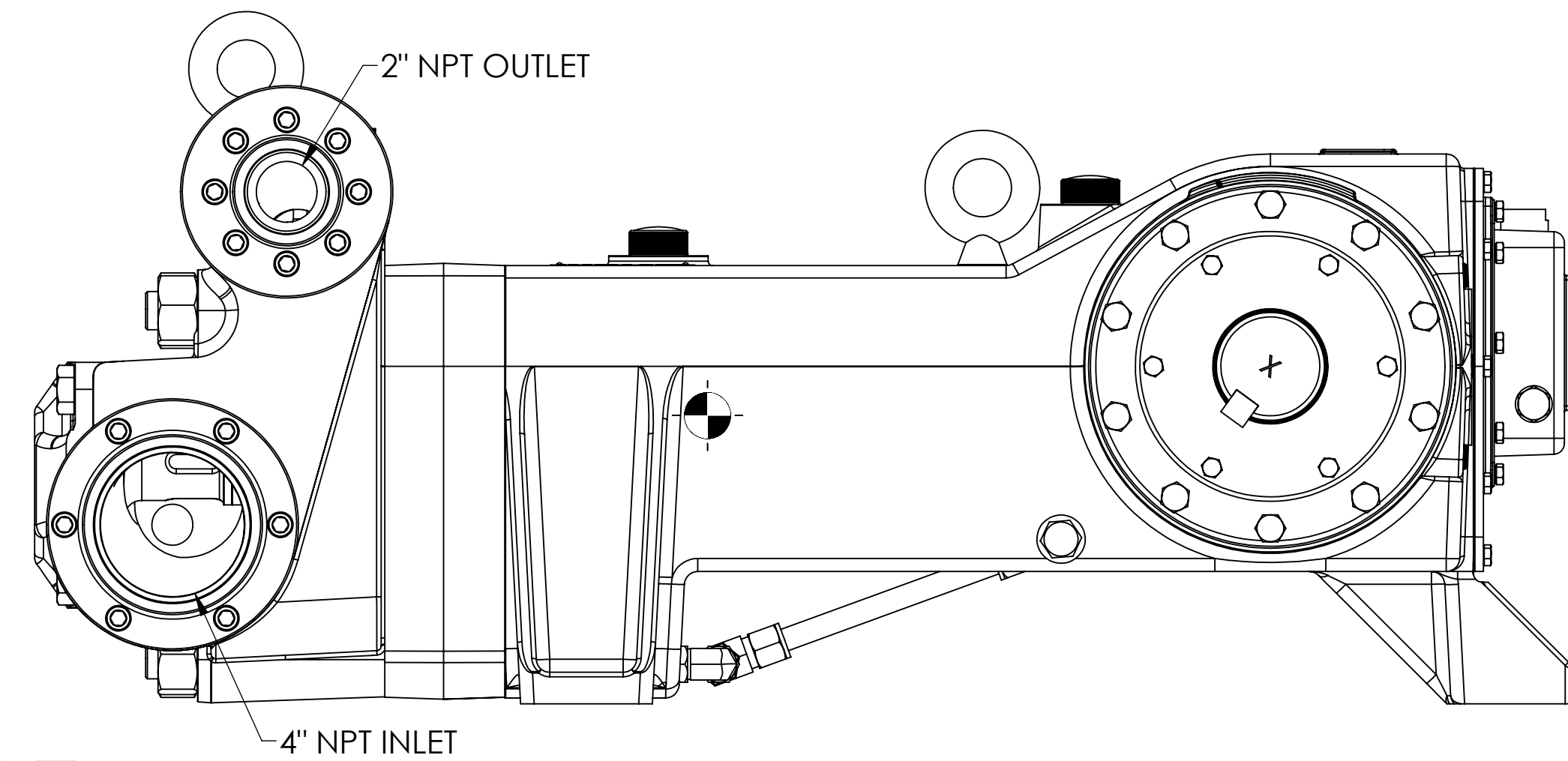
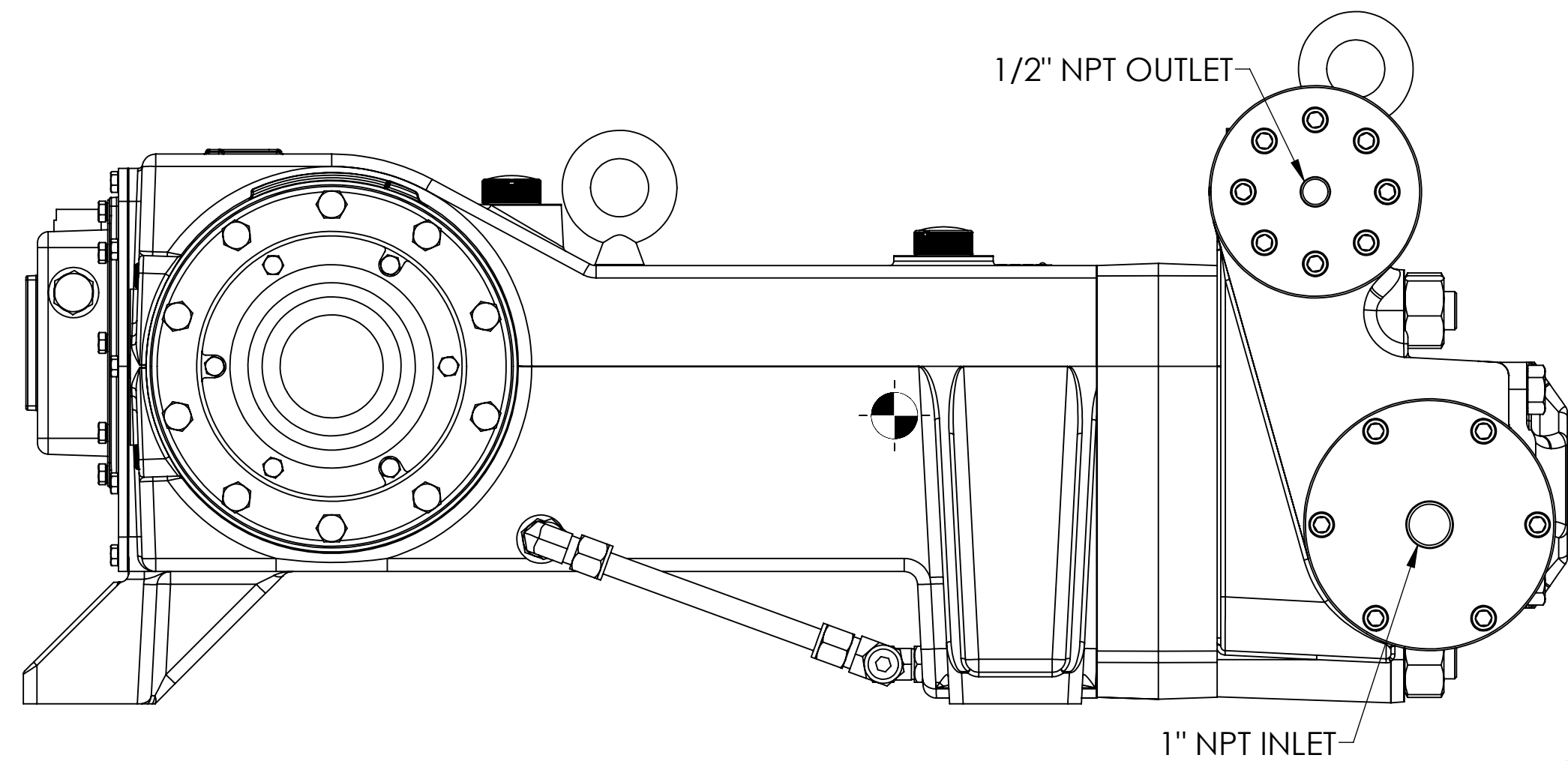

NPT FLANGE

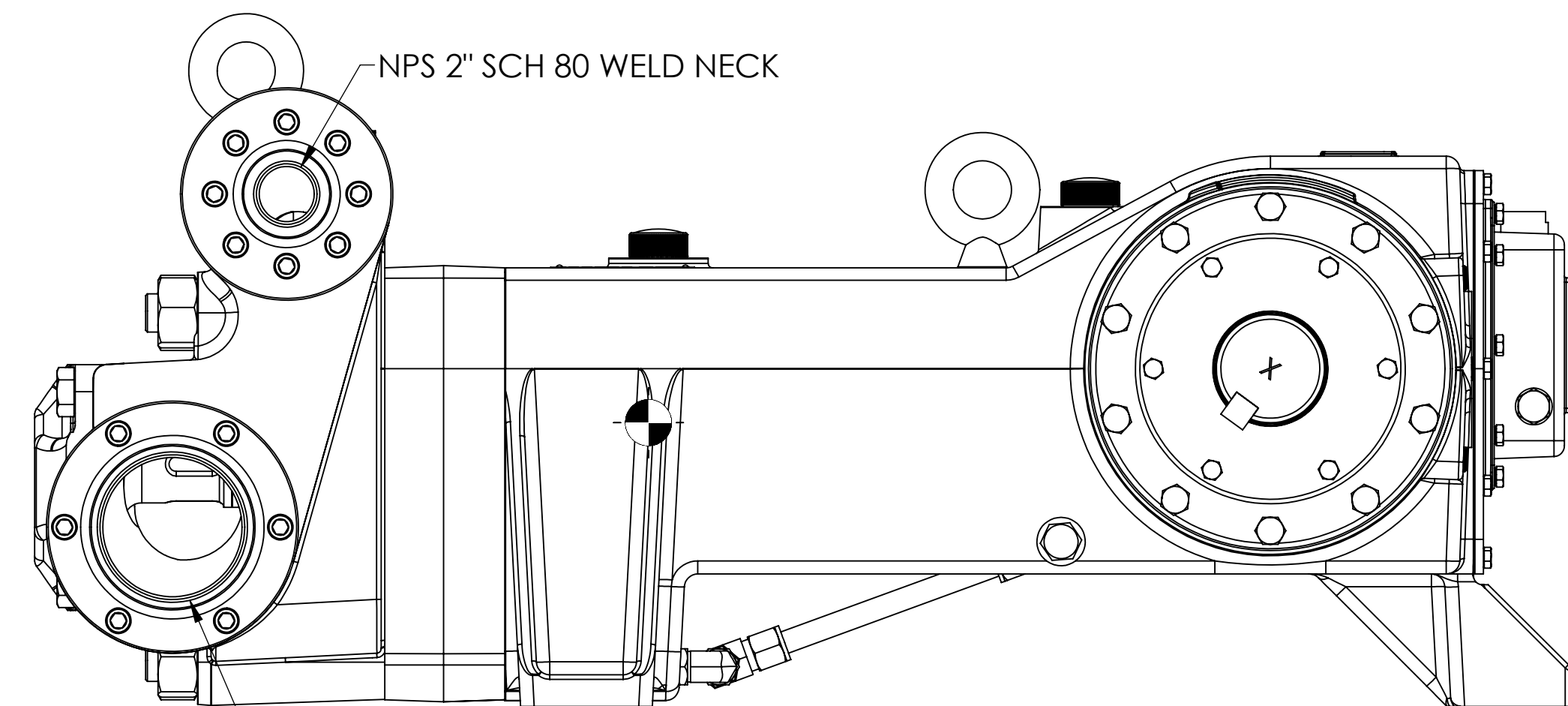
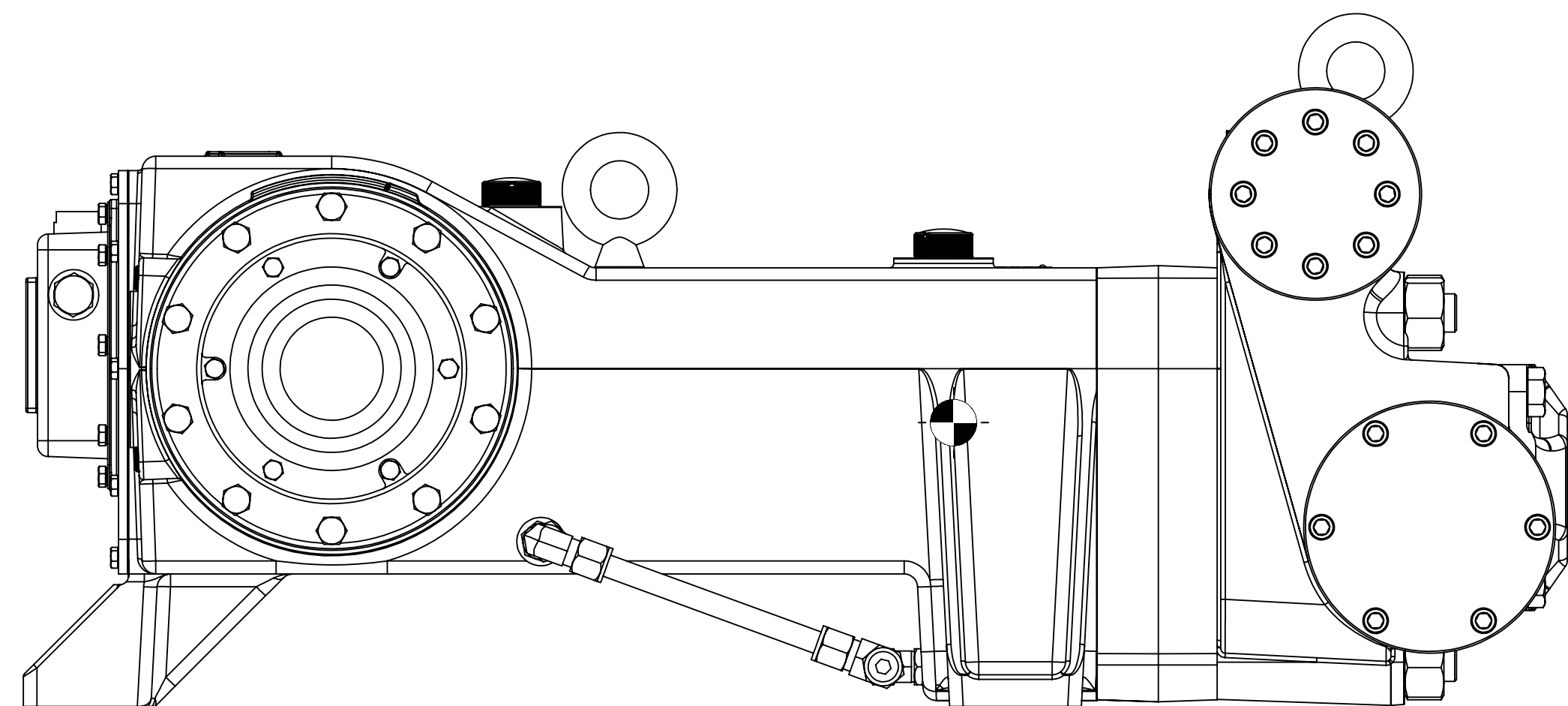

WELD NECK FLANGE

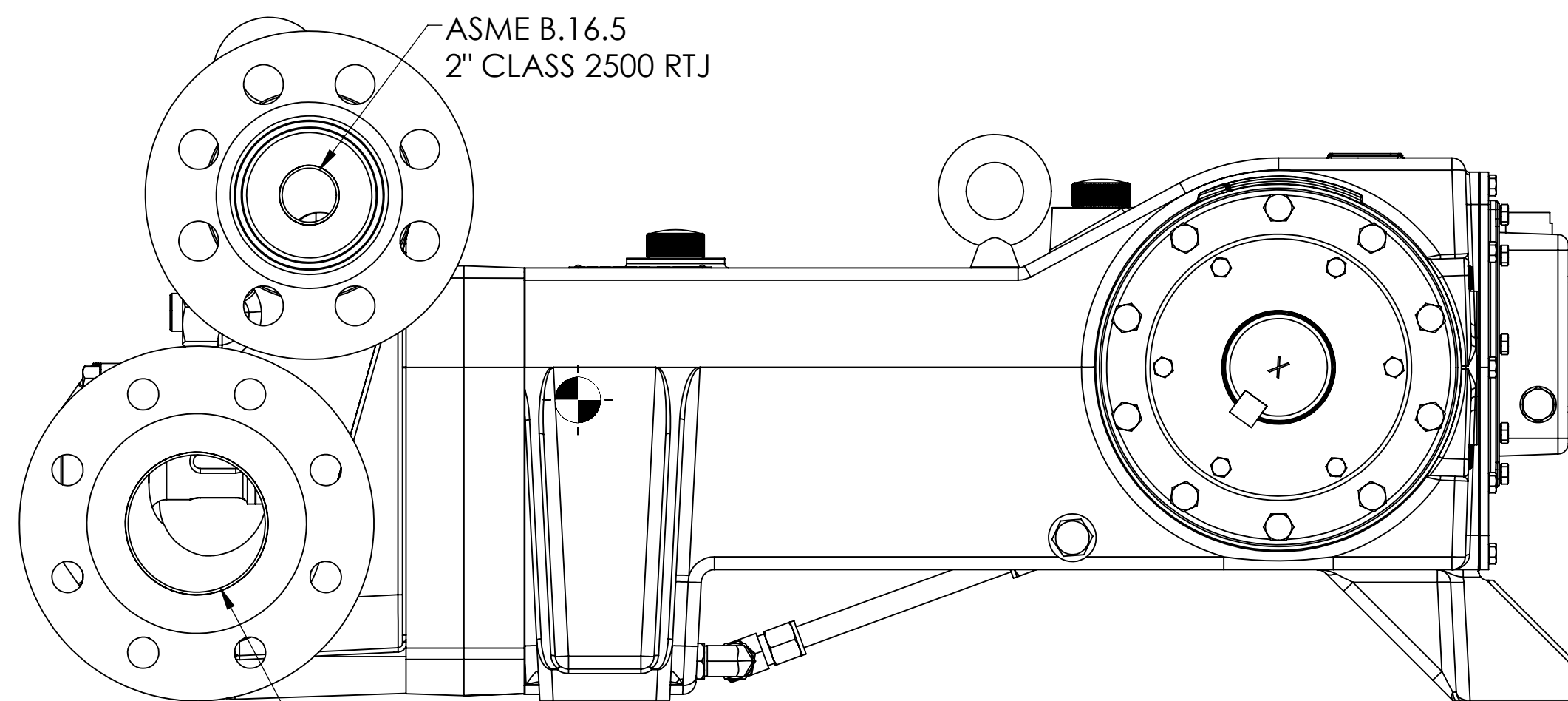
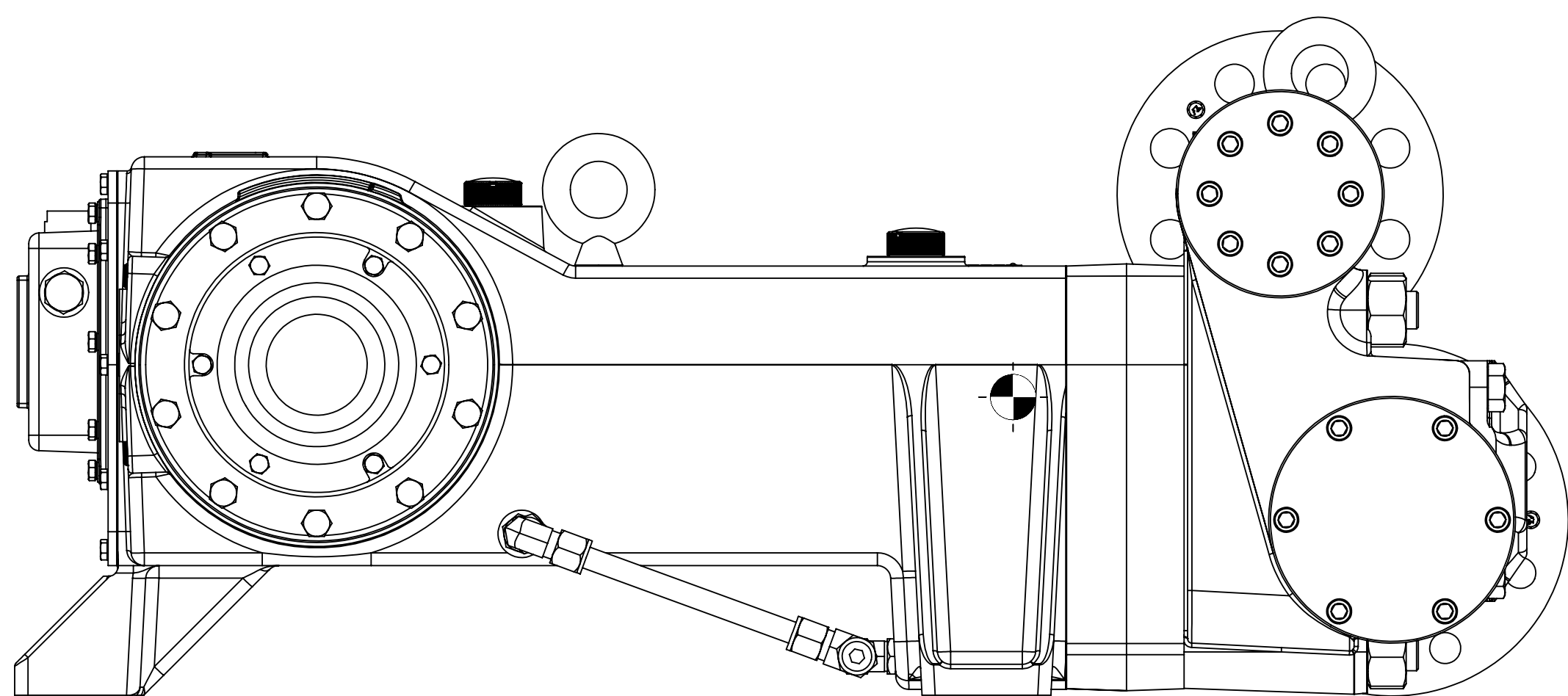

ANSI FLANGE