

S5N-Px SERIE BEDIENUNGSANLEITUNG



Informationen zur IO-Link-Kommunikation finden Sie auf der letzten Seite dieses Handbuchs.

ANZEIGE- UND BEDIENELEMENTE

OUTPUT LED (S5N-Px...B01/C01/T01)

Die gelbe LED signalisiert, Ausgang NO ist geschlossen.

STABILITÄTS LED (S5N-Px...B01/C01)

Die grüne LED signalisiert den sicheren Betriebszustand, wobei das empfangene Signal im Vergleich zur Schaltschwelle größer als 30% ist.

TRIMMER (S5N-Px...B01/C01/C21/E01/F01/T01)

Mit dem Trimmer kann die Empfindlichkeit eingestellt werden. Drehung im Uhrzeigersinn vergrößert die Reich- oder Tastweite.

Achtung: Der Drehwinkel des Trimmers ist auf 270° mechanisch begrenzt. Wenden Sie keine extreme Kraft bei der Einstellung an (max. 40Nm).

INSTALLATION

Der Sensor ermöglicht aufgrund seiner M18x1 Gewindebauform und unter Verwendung von zwei mitgelieferten Muttern (SW 24mm/max. Drehmoment 1.5 Nm) sowie einer speziellen Druckscheibe, die Montage durch eine einfache Bohrung mit Ø 18 mm.

Zudem kann der Sensor auch mit zwei Schrauben (M3x22 oder länger) und Unterlegscheiben mittels Gehäusebohrungen befestigt werden. Wählen Sie stets eine Befestigungsmöglichkeit, mit der beste Einsicht und einfachster Zugriff von Anzeige- und Bedienelemente gewährleistet ist.

Sensorzubehör: Muttern mit SW 22mm/h=8mm (max. Drehm. 2 Nm) und einer Vielzahl an Haltewinkeln, garantieren verbesserte und einfache Sensorbefestigung (s. auch Kapitel Zubehör in Katalog od. Datenblatt).

Angaben bzgl. Reich-/Tastweite beziehen sich ab Optikfläche.

C Modelle: Die Erfassung eines Objektes wird verbessert, wenn die Entfernung von Objekt zur Optikfläche vergrößert oder verringert wird und die Bewegungsrichtung des Objektes gem. nebenstehender Abbildung beachtet wird.



ANSCHLUSS

Der Anschluß entspricht der EN 60957-5-2

M12-STECKERVERSION

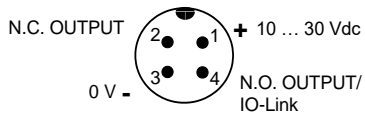

ABMESSUNGEN

AXIALE VERSION

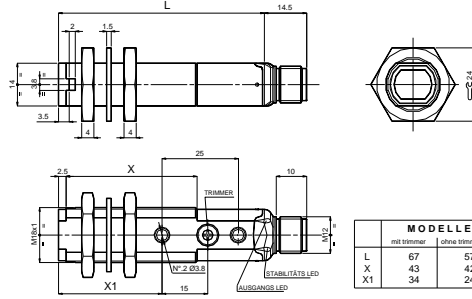

RADIALE VERSION

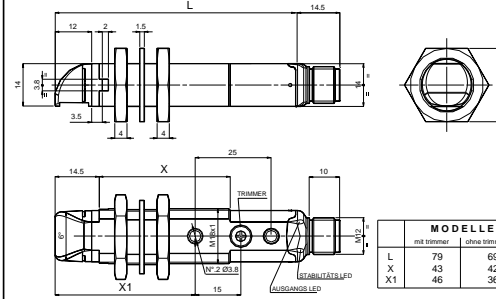

LICHTLEITER VERSION

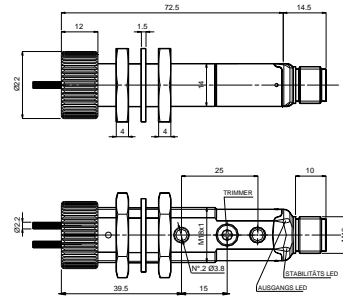

MODELLE	
	ohne Trimmer
L	67
X	43
X1	34

MODELLE	
	mit Trimmer
L	79
X	43
X1	46

TECHNISCHE DATEN

	S5N-PA AXIALE VERSION	S5N-PR RADIALE VERSION
Betriebsspannung:	10 ... 30 Vdc (begrenzte Werte)	
Welligkeit:	2 Vpp max.	
Stromaufnahme (ohne Last):	35 mA max.	
Ausgänge:	NO und NC; PNP oder NPN (kurzschlußfest)	
Ausgangsstrom:	100 mA max.	
Kapazitive Last:	C _{max} ≤ 1.5 µF @24V, I _{load} = 100mA C _{max} ≤ 3.5 µF @24V, I _{load} = 10mA	
Sättigungsspannung:	2 V max.	
Ansprechzeit:	0.5 ms (2 ms bei Mod. F01/G00)	
Schaltfrequenz:	1 KHz (250 Hz bei Mod. F01/G00)	
Anzeigen:	OUTPUT LED (gelb) ausgenommen Mod. G00 STABILITÄT LED (grün) bei Mod. B01/C01/C21/E01/F01 POWER ON LED (grün) bei Mod. G00	
Empfindlichkeitseinstellung:	Trimmer bei Mod. B01/C01/C21/E01/F01/T01	
Betriebstemperatur:	-25 ... 55°C	
Lagertemperatur:	-25 ... 70°C	
Dielektrische Durchschlagsfestigkeit:	500 Vca 1 min. zwischen elektronischen Teilen und Gehäuse	
Isolationswiderstand:	>20 MΩ 500 Vdc, zwischen elektronischen Teilen und Gehäuse	
Reich-/Tastweiten (typische Werte):	B01: 0.1 ... 3.5 m gegen R2 C01: 0 ... 60 cm T01: 0.1 ... 1 m gegen R2	B01: 0.1 ... 2 m gegen R2 C01: 0 ... 35 cm T01: 0.1 ... 1 m gegen R2
Sender, Wellenlänge:	ROT, 630 nm (bei Mod. E01) / ROT, 660 nm (bei Mod. B01/T01) INFRAROT, 880 nm (bei Mod. C01/C21/G00)	
Umgebungshelligkeit:	gem. EN 60947-5-2	
Vibration:	Amplitude 0.5 mm, Schaltfrequenz 10 ... 55Hz, für allen Achsen (EN60068-2-6)	
Schockbeständigkeit:	11 ms (30 G) 6 Schocks für allen Achsen (EN60068-2-27)	
Gehäuse:	PBT	
Linsen:	PMMA	
Schutzart:	IP67	
Anschluß:	M12 Stecker 4-polig 25 q Stecker Version	
Gewicht:		
AtEx 2014/34/EU	I 1 3G EX nA II T6 ; I 1 3D EX II A22 IP67 T85°C	

EINSTELLUNG

Ausrichtung S5N-Px...B01/T01

Montieren Sie den Sensor und den Reflektor gegenüberliegend. Drehen Sie den Trimmer auf Maximum. Ermitteln Sie durch vertikale und horizontale Bewegung die Einschaltpunkte (gelbe LED geht an) und fixieren dann den Sensor zentrisch zwischen den Einschaltpunkten. Optimale Einstellung ist gegeben, wenn die grüne LED (Mod. B01) EIN und die gelbe LED AUS ist.

B01 Model: Falls notwendig, Empfindlichkeit mittels Trimmer reduzieren um sehr kleine Objekte zu detektieren. Die Ausrichtung wird verbessert wenn diese Prozedur mehrmals wiederholt wird, während die Empfindlichkeit jeweils zurückgenommen wird.

T01 Model: Trimmer gegen Uhrzeigersinn drehen bis gelbe LED leuchtet (Stellung A). Trimmer nun wieder langsam im Uhrzeigersinn drehen bis gelbe LED erlischt (Betriebsbereitschaft, Stellung B).



Ausrichtung S5N-Px...C01

Montieren Sie den Sensor und drehen Sie den Trimmer auf Minimum: Die grüne LED ist ein, die gelbe LED ist aus. Platzieren Sie das Objekt vor dem Sensor. Drehen Sie den Trimmer im Uhrzeigersinn bis die gelbe LED leuchtet (Objekt detektiert, Stellung A). Entfernen Sie das Objekt, die gelbe LED erlischt. Drehen Sie den Trimmer im Uhrzeigersinn bis die gelbe LED leuchtet (Hintergrund detektiert, Stellung B). Erreichen Sie Maximum Stellung, wird der Hintergrund nicht detektiert. Drehen Sie nun den Trimmer, genau mittig zwischen Stellung A und B, in Stellung C. Die grüne LED muß ständig leuchten.

Datasensing S.r.l.

Strada S. Caterina 235 - 41122 Modena - Italy
 Tel: +39 059 420411 - Fax: +39 059 253973 - www.datasensing.com

Die Gewährleistungsfrist für dieses Produkt beträgt 36 Monate. Für weitere Informationen siehe allgemeine Verkaufsbedingungen unter www.datasensing.com.



Informationen zur Entsorgung von Elektro- und Elektronik-Altgeräten (WEEE) erhalten Sie auf der Webseite www.datasensing.com.

© 2007 - 2022 Datasensing S.r.l • ALLE RECHTE VORBEHALTEN. • Ohne die im Urheberrecht festgelegten Rechte einzuschränken, darf kein Teil dieses Dokuments ohne die ausdrückliche schriftliche Erlaubnis von Datasensing S.r.l., in einem Datenabfragesystem gespeichert oder eingeführt oder in irgendeiner Form, mittels irgendwelcher Methode oder für irgendwelchen Zweck übermittelt werden. • Datasensing und das Logo von Datasensing sind Handelsmarken von Datasensing S.r.l. • Datalogic und das Logo von Datalogic sind eingetragene Handelsmarken von Datalogic S.p.A. in vielen Ländern, einschließlich den USA und der EU.

S5N-Px 系列 说明手册



有关 IO-Link 通信的信息，请参阅本手册最后一页。

控制

输出 LED (S5N-Px...B01/C01/T01)

黄色 LED 亮起表示 NO 输出状态为已关闭。

稳定性 LED (S5N-Px...B01/C01)

绿色 LED 亮起表示接收到的信号具有比输出开关值大 30% 的保留。

微调器 (S5N-Px...B01/C01/T01)

微调器可用于调节灵敏度；顺时针转动微调器时，工作距离增加。

警告：微调器的旋转通过机械限位器限制在 270°。

调整时请勿施加过大的扭矩（最大 40 Nm）。

安装

使用专用垫圈和两个封闭式 CH.24 螺母（最大拧紧扭矩 1.5Nm），可以通过 M18x1 螺纹体经 \varnothing 18mm 孔将传感器固定。

或者，可以使用两个螺钉（M3x22 或更长）和垫圈通过外壳的两个孔安装传感器。

在各种可能的解决方案中，我们建议选择能够提供信号 LED 的最佳可见性和最方便使用微调器的组合。

附件种类繁多：22mm 螺母、h=8mm（2Nm 最大拧紧扭矩）可用于保证更高的扭矩，各种可定向固定支架可简化传感器定位（请参阅总目录中列出的附件）。

从传感器镜头的前表面开始测量工作距离。
C 型号：为提高检测效率，必须使物体靠近或远离传感器镜头的前表面。

在横向平移的情况下，物体必须按如图所示方式移动。



连接

连接符合 EN 60947-5-2 标准。

M12 连接器

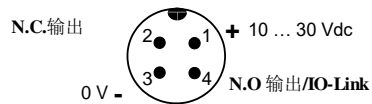

尺寸

轴向版本

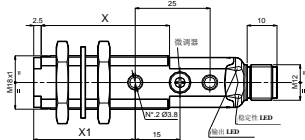
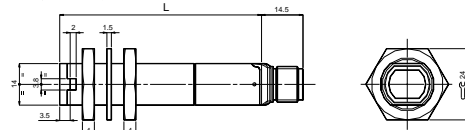

型号	带微调器	不带微调器
L	67	57
X	43	42
X1	34	24

光纤版

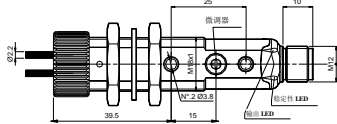
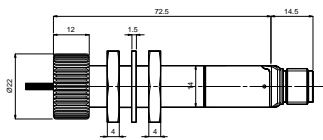

径向版本

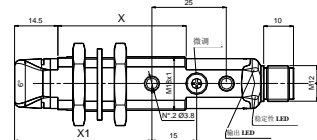
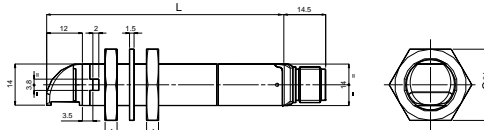

型号	带微调器	不带微调器
L	79	69
X	43	42
X1	46	36

mm

技术数据

	S5N-PA 轴向版本	S5N-PR 径向版本
电源：	10 ... 30 Vdc (极限值)	
纹波：	最大 2 Vpp	
电流消耗 (不包括输出电流)：	最大 35 mA。	
输出：	NO 和 NC: PNP 或 NPN (短路保护)	
输出电流：	最大 100 mA。	
电容性负载：	C _{max} ≤ 1.5 uF @24V, I _{load} = 100mA C _{max} ≤ 3.5 uF @24V, I _{load} = 10mA	
输出饱和电压：	最大 2 V。	
响应时间：	0.5 ms (F01/G00 型号为 2 ms)	
开关频率：	1kHz (F01/G00 型号为 250 kHz)	
指示灯：	输出 LED (黄色)，不包括 G00 型号 稳定性 LED (绿色) (B01/C01/C21/E01/F01 型号) 开机 LED (绿色) (G00 型号)	
设置：	灵敏度微调器 (B01/C01/C21/E01/F01/T01 型号)	
工作温度：	-25 ... 55 ° C	
储存温度：	-25 ... 70 ° C	
绝缘强度：	500 Vac 1 min., 电子设备与外壳之间	
绝缘电阻：	>20 M Ω 500 Vdc, 电子设备与外壳之间	
工作距离 (典型值)：	B01: R2 上 0.1...3.5 m C01: 0...60 cm T01: R2 上 0.1...1 m	B01: R2 上 0.1...2 m C01: 0...35 cm T01: R2 上 0.1...1 m
发射类型：	红色 (630 nm) (E01 型号) / 红色 (660 nm) (B01/T01 型号) / 红外 (880nm) (C01/C21/G00 型号)	
环境光抑制：	符合 EN 60947-5-2	
振动：	每个轴 0.5 mm 振幅, 10 ... 55 Hz 频率 (EN60068-2-6)	
抗冲击性：	每个轴 11 ms (30 G) 6 次冲击 (EN60068-2-27)	
外壳材料：	PBT	
镜头材料：	PMMA	
机械保护：	IP67	
连接：	M12 - 4 针连接器	
重量：	连接器版本最大 25 g.	
ATEX 2014/34/EU:	I I 3G EX nA II T6 I I 3D EX tD A22 IP67 T85 ° C	

设置

S5N-Px...B01/T01 设置

将传感器和反射镜相对放置。

将灵敏度微调器转动到最大位置。

垂直和水平移动传感器，确定黄色 LED (输出) 的开启和关闭点，然后将传感器安装在定义点的中间。当绿色 LED (B01 型号) 亮起并且黄色 LED 熄灭时，可获得最佳运行。

B01 型号：如有必要，降低灵敏度以检测非常小的目标。为改善对准，请重复上文详细介绍的步骤，同时逐渐降低灵敏度。

T01 型号：逆时针转动灵敏度微调器，直到黄色 LED 亮起 (位置 A)。再次缓慢转动微调器，直到黄色 LED 熄灭 (工作条件，位置 B)。



S5N-Px...C01 设置

将灵敏度微调器转动到最小：绿色 LED 亮起，黄色 LED 熄灭。将要检测的目标放置在传感器或光纤端子前面。顺时针转动灵敏度微调器，直到黄色 LED 亮起 (目标检测状态，位置 A)。

移除目标，黄色 LED 熄灭。

顺时针转动灵敏度微调器，直到黄色 LED 亮起 (背景检测状态，位置 B)。

如果没有检测到背景，则微调器达到最大值。

将微调器转动到位置 A 和 B 之间的中间位置 C。绿色 LED 必须亮起。

Datasensing S.r.l.

Strada S. Caterina 235 - 41122 Modena - Italy
电话：+39 059 420411 - 传真：+39 059 253973 - www.datasensing.com

本产品的保修期为 36 个月。有关详细信息，请参阅“一般销售条款和条件”。



有关处置报废电子电气设备 (WEEE) 的信息，请参阅网站 www.datasensing.com。

© 2007 - 2022 Datasensing S.r.l. ◆ 保留所有权利 ◆ 在不限制版权所有权，或未经 Datasensing S.r.l. 的书面许可的情况下，不得对此文档的任何一部分进行复制、存储或将其引入检索系统，不得以任何形式、通过任何方法对此文档进行传播，不得将此文档用于任何目的。◆ Datasensing 和 Datasensing 徽标是 Datasensing S.r.l. 的商标。◆ Datalogic 和 Datalogic 标志是 Datalogic S.p.A. 在美国和欧盟等许多国家或地区的注册商标。



S5N

IO-Link® parameters

PHYSICAL LAYER

Description	
IO-Link Revision	1.1
SIO Modus	YES
Min Cycle Time	5 ms (LED models) / 8 ms (Laser models)
Transmission Rate	38,4 kbit/s (COM2)
Process Data Length	PDInput: 24 Bit PDOOutput: 1 Bit
M-Sequence Capability	PREOPERATE: TYPE_0 OPERATE: TYPE_2_V ISDU: supported

FEATURES

Description	
Block Parameter	YES
Data Storage	YES
Supported Access Locks	Parameter (write) access Data Storage
Profile Characteristic	Device Profile: Smart Sensor Function Class: Device Identification Function Class: Binary Data Channel Function Class: Process Data Variable Function Class: Device Diagnosis Function Class: Teach Channel Function Class: Teach-in Single Value Function Class: Transducer Disable

SERVICE DATA

The following ISDUs will not be saved via Data Storage: Device Access Locks (index 0xC), Teach-in Channel (index 0x3A), Adjustment Mode (index 0x66)

System Parameters							
Index (dec)	Parameter Object Name	Length	Subindex (offset)	Value/Range	Description	Data Type	Access*
0x000C (12)	Device Access Locks	2 octets		Bit 1: Data Storage (0 = unlocked, 1 = locked)	Standardized Device locking functions: Bit 0: Parameter (write) access (not used) Bit 1: Data Storage Bit 2: Local parameterization (Not used) Bit 3: Local user interface (Not used) Bit 4-15: Reserved	RecordT	R/W
0x000D (13)	Profile Characteristics	2 octets 2 octets 2 octets 2 octets 2 octets 2 octets 2 octets		0x0001 0x8000 0x8001 0x8002 0x8003 0x8004 0x8007 0x800C	Smart Sensor Profile Device Identification Binary Data Channel (BDC) Process Data Variable (PDV) Device Diagnosis Teach Channel Teach-in single value Transducer Disable	ArrayT of UIntegerT16	RO
0x000E (14)	PDInput Descriptor	3 octets 3 octets 3 octets 3 octets		0x01.0x01.0x00 0x01.0x01.0x01 0x01.0x01.0x02 0x01.0x01.0x03 0x02.0x10.0x08	SSC1 (OUT0) SSC2 (OUT1) TEACH STATUS FLAG STABILITY (C01) / ALARM (B01) PDV1 (NORMALIZED DISTANCE (M03) / LIGHT RECEIVED (W03, B01, C01, T01))	ArrayT of OctetStringT3	RO
0x000F (15)	PDOOutput Descriptor	3 octets		0x01.0x01.0x00	TRANSDUCER DISABLE	ArrayT of OctetStringT3	RO

*RO = read only, WO = write only, R/W = read/write

Identification Parameters								
Index (dec)	Parameter Object Name	Length	Subindex (offset)	Value/Range	Description	Data Type	Access*	Remark
0x0010 (16)	Vendor Name	9 octets		DATALOGIC	Informative	StringT	RO	
0x0011 (17)	Vendor Text	19 octets		Empower your vision		StringT	RO	
0x0012 (18)	Product Name	15 octets		See "Device variant collection" on page 5	Detailed product name	StringT	RO	
0x0013 (19)	Product ID	5 octets		See "Device variant collection" on page 5	Product identification	StringT	RO	
0x0014 (20)	Product Text	21 octets		See "Device variant collection" on page 5		StringT	RO	
0x0015 (21)	Serial Number	9 octets			Unique serial number	StringT	RO	
0x0016 (22)	Hardware Revision	5 octets		RevAE		StringT	RO	
0x0017 (23)	Firmware Revision	5 octets		5.0.0		StringT	RO	
0x0018 (24)	Application Specific Tag	32 octets		*** (default)	Tag application defined by user	StringT	R/W	Saved in non-volatile memory
0x0019 (25)	Function Tag	32 octets		*** (default)	Additional tag for device function identification	StringT	R/W	Saved in non-volatile memory
0x001A (26)	Location Tag	32 octets		*** (default)	Additional tag for device function identification	StringT	R/W	Saved in non-volatile memory

Observation / Diagnostic Parameters								
Index (dec)	Parameter Object Name	Length	Subindex (offset)	Value/Range	Description	Data Type	Access*	Remark
0x0028 (40)	Process Data Input	3 octets			Read last valid Process Data Input from PDin channel	Device specific	RO	
0x0029 (41)	Process Data Output	1 octet			Read last valid Process Data Output from PDout channel	Device specific	RO	
0x0052 (82)	Device Temperature	2 octets 2 octets 2 octets 2 octets 2 octets	1(64) 2(48) 3(32) 4(16) 5(0)		Device temperature actual Device min. temperature since powerup Device max. temperature since powerup Device min. temperature during lifetime Device max. temperature during lifetime	IntegerT IntegerT IntegerT IntegerT IntegerT	RO RO RO RO RO	
0x0053 (83)	Device Temperature Threshold	2 octets 2 octets	1(16) 2(0)		Device min. temperature threshold (B01, C01, T01) Device max. temperature threshold (B01, C01, T01)	IntegerT IntegerT	R/W	Saved in non-volatile memory every hour. Events are generated if the device temperature exceeds the thresholds.
0x0057 (87)	Operating Hours	4 octets 4 octets 4 octets	1(64) 2(32) 3(0)	0...(2^32)-1	Operating Hours: device operating hours. Not resettable by user. Operating Hours Maintenance: device operating hours, reset on system command "Confirm Maintenance". Operating Hours Power Up: Time in hours since power up.	UIntegerT UIntegerT UIntegerT	RO RO RO	
0x0024 (36)	Device Status	1 octet		0x00 → Device is operating properly 0x01 → Maintenance Required 0x02 → Out of specification 0x03 → Functional Check 0x04 → Failure	Contains current status of the device	UIntegerT	RO	
0x0025 (37)	Detailed Device Status	3 octets			Information about currently pending Events. Implemented as dynamic list.	UIntegerT	RO	
0x00BE (190)	Excess gain	2 octets		100...900	Excess gain (EG) = 0 if signal is under threshold (B01 LED, C01, T01)	UIntegerT	RO	

*RO = read only, WO = write only, R/W = read/write

Teach-in Parameters								
Index (dec)	Parameter Object Name	Lenght	Subindex (offset)	Value/Range	Description	Data Type	Access*	Remark
0x003A (58)	TI Select	1 octet		0x00 = SSC1 (default, C/Q pin and DO pin)	Selection for Teach-in channel (volatile)	UIntegerT	R/W	C/Q and DO outputs are antivalent. Teach SSC1 equals to teach SSC2
0x003B (59)	TI Result	1 octet	1(0) 2(4) 3(5)	Teach-in State Flag SP1 TP1 Flag SP2 TP1	See IO-Link Smart Sensor Profile	UIntegerT4 BooleanT BooleanT	RO	
0x003C (60)	SSC1 Param	2 octets 2 octets	1(16) 2(0)	0-4095 Not used	Normalized distance (M03) / Switching threshold (W03) / Trimmer value (sensitivity adjustment) (Trimmer models)	UIntegerT	R/W	Saved in non-volatile memory
0x003D (61)	SSC1 Config	1 octet	1(24)	0x00: High Active (default C01, M03, W03) 0x01: Low Active (default B01, T01)	C/Q pin configuration	UIntegerT	R/W	Saved in non-volatile memory
		1 octet	2(16)	0x01: Single Point (default)		UIntegerT		
		2 octets	3(0)	Not used (M03) 0 ..10 Hysteresis (W03) 0 - 1 Hysteresis (Trimmer models)		UIntegerT		
0x003E (62)	SSC2 Param	2 octets 2 octets	1(16) 2(0)	0-4095 Non used	Normalized distance	UIntegerT	R/W	Saved in non-volatile memory
0x003F (63)	SSC2 Config	1 octet	1(24)	0x00: High Active (default B01, T01) 0x01: Low Active (default C01, M03, W03)	DO pin configuration	UIntegerT	R/W	Saved in non-volatile memory
		1 octet	2(16)	0x01: Single Point (default)		UIntegerT		
		2 octets	3(0)	Not used (M03) 0 ..10 Hysteresis (W03) 0 - 1 Hysteresis (Trimmer models)		UIntegerT		
0x0066 (102)	Adjustment mode	1 octet		0x00 = manual (default) 0x01 = IO-Link	Status of trimmer regulation (manual/IO-Link) (B01, C01, T01)	BooleanT	R/W	

*RO = read only, WO = write only, R/W = read/write

Device Specific Parameters								
Index (dec)	Parameter Object Name	Length	Subindex (offset)	Value/Range	Description	Data Type	Access*	Remark
0x0048 (72)	Delay Settings	1 octet	1(64)	0 = no delay (default) 0x2 = Delay ON 0x3 = One Shot 0x4 = Delay OFF	Select Delay mode (ON / OFF/ ONE SHOT)	UIntegerT	R/W	Saved in non-volatile memory
		4 octets	2(32)	0...(2 ³²)-1	Delay ON value = Delay [ms] *1000 / 141 (M03) Delay [ms] *1000 / 45 (W03) Delay [ms] *1000 / 157 (T01/C01/B01 LED emission) Delay [ms] *1000 / 67 (C01 Laser) Delay [ms] *1000 / 70 (B01 Laser)	UIntegerT	R/W	
		4 octets	3(0)	0...(2 ³²)-1	Delay OFF value = Delay [ms] *1000 / 141 (M03) Delay [ms] *1000 / 45 (W03) Delay [ms] *1000 / 157 (T01/C01/B01 LED emission) Delay [ms] *1000 / 67 (C01 Laser) Delay [ms] *1000 / 70 (B01 Laser)	UIntegerT	R/W	
0x00B4 (180)	Output type	1 octet	1(8)	0x01 = PNP (default) 0x03 = Push Pull ⁽¹⁾	Output type of C/Q pin when in SIO mode	UIntegerT	R/W	Saved in non-volatile memory
		1 octet	2(0)	0x01 = PNP (default) 0x02 = NPN 0x03 = Push Pull	Output type of DO pin	UIntegerT	R/W	

⁽¹⁾ The No Output configured in Push Pull mode with an NPN load does not reactivate after a short circuit condition. Remove the short circuit condition and cycle power to the sensor.

Standard Command						
Index (dec)	Command Name	Length	Value (dec)	Description	Access*	
0x0002 (2)	SP1 Single Value Teach	1 octet	0x41 (65)	Acquisition EASY (refer to User's Manual) (M03, W03) / Teach Set Point (B01, C01, T01)	WO	
0x0002 (2)	SP1 Teach TP1	1 octet	0x43 (67)	Acquisition FINE: Mark Detection (refer to User's Manual) (W03)	WO	
0x0002 (2)	SP1 Teach TP2	1 octet	0x44 (68)	Acquisition FINE: Background Detection (refer to User's Manual) (W03)	WO	
0x0002 (2)	Teach FINE	1 octet	0x4B (75)	Acquisition FINE (refer to User's Manual) (M03)	WO	
0x0002 (2)	Teach CANCEL	1 octet	0x4F (79)	Exit from teach FAIL status (M03) / Exit from Fine detection (W03)	WO	
0x0002 (2)	Restore Factory Settings	1 octet	0x82 (130)	Restore factory settings (Device Access Locks, Application Specific Tag, Function Tag, Location Tag, SSC1 Param, SSC2 Param, Delay Settings, Output Type, Adjust Mode)	WO	
0x0002 (2)	Confirm Maintenance	1 octet	0xA5 (165)	Reset Maintenance parameters (Operating Hours Maintenance, Minimum device temperature since powerup, Maximum device temperature since powerup, Device Status, Detailed Device Status)	WO	
0x0002 (2)	Disable IO-Link adjustment	1 octet	0xAB (171)	Disable teach via IO-Link, re-enable trimmer adjustment (B01, C01, T01)	WO	
0x0002 (2)	Start / Stop Ping	1 octet	0xAF (175)	Feature to identify the sensor by yellow led blinking	WO	

Events					
Event code (dec)	Event name	Event mode	Event type	Device status	Remarks
0x4220 (16928)	Temperature underrun	Appears / Disappears	Warning	Out of specification	only B01, C01, T01
0x4210 (16912)	Temperature overrun	Appears / Disappears	Warning	Out of specification	
0x5100 (20736)	General power supply fault	Appears / Disappears	Error	Failure	
0x7710 (30480)	Short circuit - Check installation	Appears / Disappears	Error	Failure	
0x8C40 (35904)	Maintenance required - Lens cleaning	Appears / Disappears	Notification	Maintenance required	only B01
0x8CA0 (36000)	Laser fault	Appears / Disappears	Error	Failure	only Laser models

PROCESS DATA

Process Data Output							
Byte 0							
7	6	5	4	3	2	1	0
Not used							TRANSDUCER DISABLE
Process Data Input							
Byte 2							
23	22	21	20	19	18	17	16
PDV1 (Normalized distance (M03) ⁽²⁾ / LIGHT RECEIVED (W03, B01, C01, T01) (MSB))							
Byte 1							
15	14	13	12	11	10	9	8
PDV1 (Normalized distance (M03) ⁽²⁾ / LIGHT RECEIVED (W03, B01, C01, T01) (LSB))							
Byte 0							
7	6	5	4	3	2	1	0
Not used				Not used (W03, M03, T01), Stability (C01) Alarm (B01)	TEACH-IN	SSC2 (DO pin)	SSC1 (C/Q pin)

⁽²⁾ Process data will not be valid in case of out-of-range values.

DEVICE VARIANT COLLECTION

Product name	Product ID	Product text	Device ID
S5N-PA-5-C01-OZ	02210	Diffuse proximity	2
S5N-MA-5-C01-OZ	22200	Diffuse proximity	
S5N-PA-5-M03-OZ	02230	Background suppression	3
S5N-MA-5-M03-OZ	22170	Background suppression	
S5N-PA-5-W03-OZ	02240	Mark reader	4
S5N-PL-5-C01-OZ	02260	Diffuse proximity laser	5
S5N-ML-5-C01-OZ	22190	Diffuse proximity laser	
S5N-PL-5-B01-OZ	02250	Reflex polarized laser	6
S5N-ML-5-B01-OZ	22180	Reflex polarized laser	
S5N-PA-5-B01-OZ	02200	Reflex polarized	7
S5N-MA-5-B01-OZ	22160	Reflex polarized	
S5N-PA-5-T01-OZ	02220	Reflex transparent	8

EN	CE Compliance
<p>CE marking states the compliance of the product with essential requirements listed in the applicable European directive. Since the directives and applicable standards are subject to continuous updates, and since the manufacturer promptly adopts these updates, therefore the EU declaration of conformity is a living document. The EU declaration of conformity is available for competent authorities and customers through the manufacturer's commercial reference contacts. Since April 20th, 2016 the main European directives applicable to the products require inclusion of an adequate analysis and assessment of the risk(s). This evaluation was carried out in relation to the applicable points of the standards listed in the Declaration of Conformity. These products are mainly designed for integration purposes into more complex systems. For this reason, it is under the responsibility of the system integrator to do a new risk assessment regarding the final installation.</p> <p>Warning This is a Class A product. In a domestic environment this product may cause radio interference in which case the user may be required to take adequate measures.</p>	

IT	Conformità CE
<p>La marcatura CE dichiara la conformità del prodotto con i requisiti essenziali elencati nella direttiva europea applicabile. Essendo le direttive e le normative applicabili soggette a continui aggiornamenti, e dato che il costruttore adotta immediatamente tali aggiornamenti, la dichiarazione di conformità CE è un documento vivo. La dichiarazione di conformità CE è disponibile per le autorità competenti e i clienti tramite i contatti commerciali di riferimento al costruttore. Dal 20 aprile 2016, le principali direttive europee applicabili ai prodotti richiedono l'inserimento di un'adeguata analisi e valutazione dell/i rischi(o). Tale valutazione è stata realizzata in relazione ai punti applicabili delle normative elencate nella Dichiarazione di Conformità. Questi prodotti sono progettati principalmente per essere integrati in sistemi più complessi. Per questo motivo, l'integratore di sistemi è responsabile della realizzazione di una nuova valutazione dei rischi riguardante l'installazione finale.</p> <p>Attenzione Si tratta di un prodotto di Classe A. In un ambiente domestico questo prodotto può generare interferenze radio. In tal caso è necessario prendere le dovute misure.</p>	

DE	EG-Konformität
<p>Die CE-Kennzeichnung bestätigt die Konformität des Produkts mit den wesentlichen Anforderungen der geltenden europäischen Richtlinien. Da die Richtlinien und anwendbaren Normen laufend aktualisiert werden und der Hersteller diese Aktualisierungen umgehend übernimmt, ist die EU-Konformitätserklärung ein fortschreitendes Dokument. Die EU-Konformitätserklärung ist für zuständige Behörden und Kunden über die Handelskontakte von dem Hersteller erhältlich. Seit dem 20. April 2016 erfordern die wichtigsten für diese Produkte anwendbaren Europäischen Richtlinien die Integration einer angemessenen Analyse und der Bewertung der Risiken. Diese Bewertung wird in Bezug auf die anwendbaren Punkte der in der Konformitätserklärung aufgelisteten Normen durchgeführt. Diese Produkte werden in erster Linie für die Integration in komplexere Systeme ausgelegt. Aus diesem Grund liegt es in der Verantwortung des Systemintegrators, eine neue Risikobewertung der Endinstallation vorzunehmen.</p> <p>Warnung Dies ist ein Produkt nach Klasse A. In einem häuslichen Umfeld kann dieses Produkt Funkstörungen auslösen, gegebenenfalls hat der Benutzer dann angebrachte Maßnahmen zu ergreifen.</p>	

FR	Conformité CE
<p>La marque CE indique la conformité du produit aux exigences essentielles énoncées dans la directive européenne applicable. Les directives et les normes applicables sont sujettes à des mises à jour de manière continue et le constructeur adopte rapidement ces mises à jour ; la déclaration de conformité UE est par conséquent un document vivant. La déclaration de conformité UE est disponible aux autorités compétentes et aux clients à travers les interlocuteurs commerciaux de référence des constructeurs. Depuis le 20 Avril 2016 les principales directives européennes applicables aux produits exigent l'inclusion d'une analyse et d'une évaluation adéquates du/des risque/s. Cette évaluation a été réalisée en relation avec les points applicables des normes indiquées dans la Déclaration de Conformité. Ces produits sont principalement conçus à des fins d'intégration dans des systèmes plus complexes. Pour cette raison, il est de la responsabilité de l'intégrateur de système d'effectuer une nouvelle évaluation des risques concernant l'installation finale.</p> <p>Avertissement Ceci est un produit de Classe A. Dans un environnement domestique, ce produit peut provoquer des interférences radio auquel cas l'utilisateur peut se trouver dans l'obligation de prendre des mesures adéquates.</p>	

ES	Conformidad CE
<p>La marca CE establece la conformidad del producto con los requisitos fundamentales enumerados en la directiva europea aplicable. Debido a que las directivas y normativas aplicables están sujetas a actualización continua, como el constructor adopta estas actualizaciones de inmediato, la declaración de conformidad UE es un documento activo. La declaración de conformidad UE está disponible para las autoridades competentes y para los clientes a través de los contactos comerciales de referencia del constructor. Desde el 20 de abril de 2016, las principales directivas europeas aplicables a los productos exigen la inclusión de un idóneo análisis y evaluación de riesgos. Esta evaluación ha sido efectuada sobre los puntos aplicables de la normativa indicada en la Declaración de Conformidad. Estos productos han sido diseñados a fin de ser integrados en sistemas más complejos. Por ello, es responsabilidad del integrador del sistema efectuar una nueva evaluación de riesgos relativa a la instalación final.</p> <p>Advertencia Este es un producto de Clase A. En un entorno doméstico, este producto puede causar interferencias radioeléctricas; en este caso, el usuario debería tomar medidas adecuadas.</p>	

NL	EU-conformiteitsverklaring
<p>Met de CE-markering wordt verklaard dat het product voldoet aan de essentiële eisen zoals vermeld in de toepasselijke Europese richtlijnen. Daar de richtlijnen en de toepasselijke normen onderhevig zijn aan voortdurende aanpassingen, en de fabrikant deze aanpassingen direct toepast, is de EU-conformiteitsverklaring een levend document. De EU-conformiteitsverklaring is beschikbaar voor bevoegde autoriteiten en klanten via contactgegevens voor commerciële referentie. Sinds 20 april 2016 vereisen de belangrijkste Europese richtlijnen de inclusie van een adequate risicoanalyse- en beoordeling. Deze beoordeling werd uitgevoerd met betrekking tot de toepasselijke punten van de normen zoals vermeld in de Conformiteitsverklaring. Deze producten zijn voornamelijk ontworpen voor integratie in complexere systemen. Om deze reden is het de verantwoordelijkheid van de systeemintegrator om een nieuwe risicobeoordeling uit te voeren met betrekking tot de definitieve installatie.</p> <p>Waarschuwing Dit is een Klasse A product. In een woonomgeving kan dit product radiostoring veroorzaken, in welk geval de gebruiker mogelijk verplicht is om adequate maatregelen te treffen.</p>	



S5N-PA/MA...M

Background suppression proximity

INSTRUCTION MANUAL



Information on IO-Link communication is available on the last page of this manual.

CONTROLS

OUTPUT LED

The yellow LED ON indicates that the N.O. (normally open) output status is closed.

READY LED

The green LED indicates a normal operating function. If the green LED flashes, the acquisition has failed. Please refer to the "SETTING" paragraph for setup procedure indications.

SET PUSHBUTTON

A long pressure on the pushbutton activates the self-setting procedure.

INSTALLATION

S5N-PA...M: The sensor can be fixed by means of the M18x1 threaded body through a \varnothing 18 mm hole, using the specific washer two CH.24 nuts enclosed (1.5 Nm maximum tightening torque). Alternatively, the sensor can be mounted through the two housing's holes using two screws (M3x22 or longer) and washer. Amongst the various possible solutions, we suggest to choose the combination that offers the best visibility of the signalling LEDs and the easiest access to the SET pushbutton. 22 mm nuts, h=8 mm, (2 Nm maximum tightening torque) are available to guarantee an improved torque.

S5N-MA...M: The sensor can be fixed by means of the M18x1 threaded body through a \varnothing 18 mm hole, using the two CH.24 nuts enclosed (22 Nm maximum tightening torque).

For both plastic version and metallic version are available various orientable fixing brackets to ease the sensor positioning (please refer to the accessories listed in the general catalogue).

The operating distance is measured from the front surface of the sensor lens. To improve the detection, the object has to be moved closer or further away from the front surface of the sensor lens. In case of lateral translation, the object must move as indicated in the figure.



CONNECTIONS

The connections are compliant to the EN 60947-5-2 standard.

M12 CONNECTOR

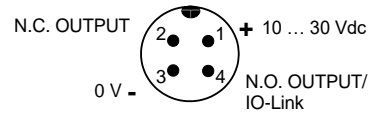

DIMENSIONS

S5N-PA VERSION

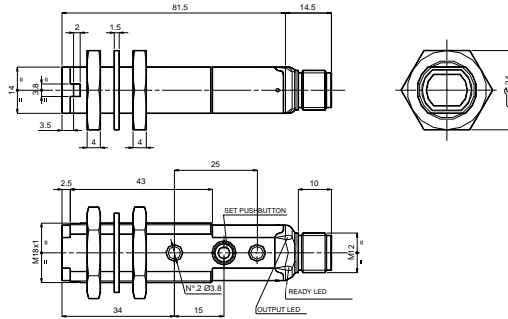

S5N-MA VERSION

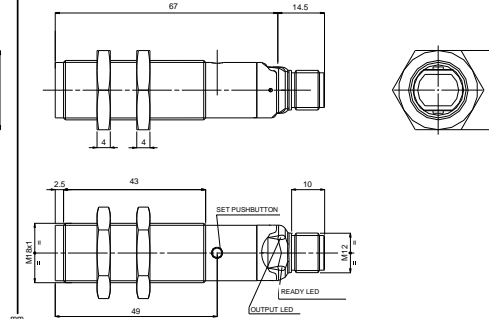

TECHNICAL DATA

	S5N-PA PLASTIC VERSIONS	S5N-MA METALLIC VERSIONS
Power supply:	10 ... 30 Vdc (limit values)	
Ripple:	2 Vpp max.	
Current consumption (output current excluded):	30 mA max.	
Outputs:	N.A. and N.C.; PNP or NPN (short-circuit protection)	
Output current:	100 mA max.	
Capacitive load:	C _{max} ≤ 1.5 uF @24V, I _{load} = 100mA C _{max} ≤ 3.5 uF @24V, I _{load} = 10mA	
Output saturation voltage:	2 V max.	
Response time:	1 ms	
Switching frequency:	500 Hz	
Indicators:	OUTPUT LED (YELLOW) / READY LED (GREEN)	
Setting:	SET pushbutton	
Operating mode:	LIGHT mode on N.O. output / DARK mode on N.C. output	
Data retention:	non volatile EEPROM memory	
Operating temperature:	-25 ... 55 °C	
Storage temperature:	-25 ... 70 °C	
Insulating strength:	500 Vac 1 min., between electronics and housing	
Insulating resistance:	>20 MΩ 500 Vdc, between electronics and housing	
Operating distance (typical values):	background suppression 50...150 mm	
Emission type:	RED (630 nm)	
Ambient light rejection:	according to EN 60947-5-2	
Vibrations:	0.5 mm amplitude, 10 ... 55 Hz frequency, for every axis (EN60068-2-6)	
Shock resistance:	11 ms (30 G) 6 shock for every axis (EN60068-2-27)	
Housing material:	PBT	Nickel plated brass
Lens material:	PMMA	
Mechanical protection:	IP67 Metal versions type 1 enclosure	
Connections:	M12 - 4 pole connector	
Weight:	25 g. max. connector vers.	60 g. max. connector vers.
AtEx 2014/34/EU	I I 3G EX nA II T6 ; I I 3D EX tD A22 IP67 T85°C	
Emission:	Exempt Risk Group (RG0) according to IEC 62471	

SETTING

EASY TOUCH™

The sensor uses the patent-covered EASY TOUCH™ technology that allows a rapid and safe self-setting of the product.

Two different setting possibilities are available:

- **EASY TOUCH™**: a long pressure of the SET pushbutton allows self-setting.
- **FINE DETECTION**: to be used only in particularly critical conditions; this setting procedure is used only when the EASY TOUCH™ is not sufficient.

Setting of S5N-PA/MA...M

To achieve a correct sensor setting, the background or the object to be suppressed has to be present during self-setting.

- EASY TOUCH™ (standard detection)

Place the background or the object to be suppressed inside the operating range.

Press the SET pushbutton until the READY LED turns OFF (1s).

Release the SET pushbutton pressed until the READY LED turns ON.

The sensor is now ready to detect all objects in the set range distinguishing them from the suppressed background.

- Fine detection

Place the background or the object to be suppressed inside the operating range.

Press the SET pushbutton. The READY LED turns OFF.

Keep the SET pushbutton pressed until the READY LED turns on (3s).

The sensor performs a fine adjustment and is ready to detect objects also very near the suppressed background.

If the green LED flashes, the acquisition has failed.

Datasensing S.r.l.

Strada S. Caterina 235 - 41122 Modena - Italy
Tel: +39 059 420411 - Fax: +39 059 253973 - www.datasensing.com

The warranty period for this product is 36 months. See General Terms and Conditions of Sales for further details.



For information about the disposal of Waste Electrical and Electronic Equipment (WEEE), please refer to the website at www.datasensing.com.

© 2018 - 2022 Datasensing S.r.l. • ALL RIGHTS RESERVED. • Without limiting the rights under copyright, no part of this documentation may be reproduced, stored in or introduced into a retrieval system, or transmitted in any form or by any means, or for any purpose, without the express written permission of Datasensing S.r.l. • Datasensing and the Datasensing logo are trademarks of Datasensing S.r.l. • Datalogic and the Datalogic logo are registered trademarks of Datalogic S.p.A. in many countries, including the U.S and the E.U.



S5N-PA/MA...M

Taster mit Hintergrundausblendung

BEDIENUNGSANLEITUNG



Informationen zur IO-Link-Kommunikation finden Sie auf der letzten Seite dieses Handbuchs.

ANZEIGE-, UND BEDIENELEMENTE

AUSGANGS LED

Die gelbe LED signalisiert, Ausgang N.O. (normalerweise geöffnet) ist geschlossen.

READY LED

Die grüne LED zeigt eine normale Betriebsfunktion an. Wenn die grüne READY LED blinkt, ist die Erfassung fehlgeschlagen. Die Hinweise zur Einrichtung finden Sie im Abschnitt "EINSTELLUNG".

SET TASTE

Ein langer Testendruck aktiviert die Einstellprozedur.

INSTALLATION

S5N-PA ... M: Der Sensor ermöglicht aufgrund seiner M18x1 Gewindebauform und unter Verwendung von zwei mitgelieferten Muttern (SW 24 mm/max. Drehmoment 1.5 Nm) sowie einer speziellen Druckscheibe, die Montage durch eine einfache Bohrung mit Ø 18 mm. Zudem kann der Sensor auch mit zwei Schrauben (M3x22 oder länger) und Unterlegscheiben mittels Gehäusebohrungen befestigt werden. Wählen Sie stets eine Befestigungsmöglichkeit, mit der beste Einsicht und einfachster Zugriff von Anzeige- und Bedienelemente gewährleistet ist.

Sensorzubehör: Muttern mit SW 22 mm/h=8mm (max. Drehm. 2 Nm) garantieren verbesserte Sensorbefestigung.

S5N-MA ... M: Der Sensor ermöglicht aufgrund seiner M18x1 Gewindebauform und unter Verwendung von zwei mitgelieferten Muttern (SW 24 mm/max. Drehmoment 22 Nm) die Montage durch eine einfache Bohrung mit Ø 18 mm.

Eine Vielzahl an Haltewinkeln garantiert für beide Versionen (Metall und Kunststoff) verbesserte und einfache Sensorbefestigung (s. auch Kapitel Zubehör in Katalog od. Datenblatt). Angaben bzgl. Reich-/Tastweite beziehen sich ab Optikfläche.

Die Erfassung eines Objektes wird verbessert, wenn die Entfernung von Objekt zur Optikfläche vergrößert oder verringert wird und die Bewegungsrichtung des Objektes gem. nebenstehender Abbildung beachtet wird.



ANSCHLUSS

Der Anschluß entspricht der EN 60957-5-2.

M12 STECKER

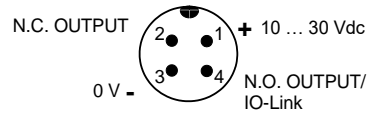

ABMESSUNGEN

S5N-PA VERSION

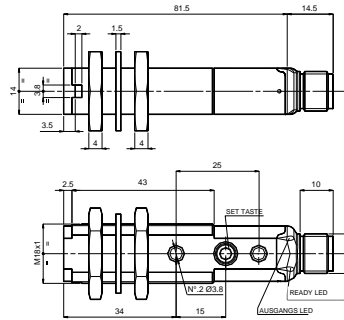

S5N-MA VERSION

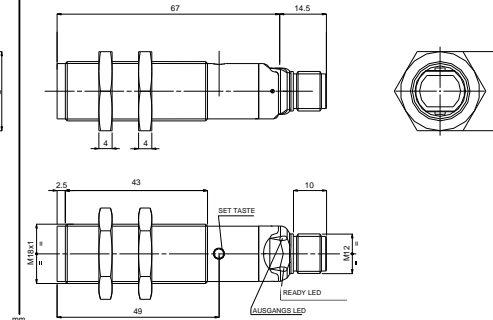

TECHNISCHE DATEN

	S5N-PA KUNSTSTOFF VERSION	S5N-MA METALL VERSION
Betriebsspannung:	10 ... 30 Vdc (begrenzte Werte)	
Welligkeit:	2 Vpp max.	
Stromaufnahme (ohne Last):	30 mA max.	
Ausgänge:	NO und NC; PNP oder NPN (kurzschlußfest)	
Ausgangsstrom:	100 mA max.	
Kapazitive Last:	C _{max} ≤ 1.5 µF @24V, I _{load} = 100mA C _{max} ≤ 3.5 µF @24V, I _{load} = 10mA	
Sättigungsspannung:	2 V max.	
Ansprechzeit:	1 ms	
Schaltfrequenz:	500 Hz	
Anzeigen:	OUTPUT LED (gelb) / READY LED (grün)	
Empfindlichkeitseinstellung:	SET Taste	
Betriebsart:	Hell bei Ausgang N.O. / Dunkel bei Ausgang N.C.	
Datenspeicherung:	Nichtflüchtiger EEPROM Speicher	
Betriebstemperatur:	-25 ... 55°C	
Lagertemperatur:	-25 ... 70°C	
Dielektrische Durchschlagsfestigkeit:	500 Vca 1 min. zwischen elektronischen Teilen und Gehäuse	
Isolationswiderstand:	>20 MΩ 500 Vdc, zwischen elektronischen Teilen und Gehäuse	
Tastweiten (typische Werte):	Hintergrundausblendung 50 ... 150 mm	
Sender, Wellenlänge:	Rot, 630 nm	
Umgebungshelligkeit:	gem. EN 60947-5-2	
Vibration:	Amplitude 0.5 mm, Schaltfrequenz 10 ... 55Hz, für allen Achsen (EN60068-2-6)	
Schockbeständigkeit:	11 ms (30 G) 6 Schocks für allen Achsen (EN60068-2-27)	
Gehäuse:	PBT	Messing vernickelt
Linien:	PMMA	
Schutzart:	IP67 Metall-Versionen Gehäuseart 1	
Anschluß:	M12 Stecker 4-polig	
Gewicht:	25 g Stecker Vers.	60 g Stecker Vers.
ATEX 2014/34/EU	II 3G EX nA II T6 ; II 3D EX ID A22 IP67 T85°C	
Emissionen:	freie Risikogruppe (RG 0) nach IEC 62471	

EINSTELLUNG

EASY TOUCH™

Der Sensor verfügt über die patentierte EASYTOUCH™ Teach-In-Einstellung. Dadurch ist stets schnelle, präzise und automatische Einstellung der Schaltschwelle garantiert.

Zwei unterschiedliche Einstellungen sind möglich:

- EASYtouch™ ; ein langer Tastendruck der SET Taste aktiviert die Einstellprozedur.
- Feineinstellung; nur anwenden, wenn die EASYTOUCH™ Teach-In-Einstellung nicht ausreichend sein sollte, oder wenn kritische Konstellationen bestehen.

Einstellung S5N-PA/MA ... M

Um eine korrekte Einstellung zu erreichen, muß während der Teach-In-Einstellung das auszublendende Objekt oder der Hintergrund verwendet werden.

- EASYTOUCH™ (Standard Einstellung)

Sensor montieren und auszublendendes Objekt oder Hintergrund innerhalb der vorgeschriebenen Tastweite platzieren.

SET Taste solange drücken bis READY LED erlischt (1s).

SET Taste loslassen und warten bis die READY LED aufleuchtet.

Der Sensor ist nun Betriebsbereit und detektiert alle Objekte innerhalb dieses erlernten Arbeitsbereiches.

- Feineinstellung

Sensor montieren und auszublendendes Objekt oder Hintergrund innerhalb der vorgeschriebenen Tastweite platzieren.

SET Taste solange drücken bis READY LED erlischt.

SET Taste weiter gedrückt halten bis die READY LED aufleuchtet (3s).

Nach loslassen der SET Taste nimmt der Sensor eine Feineinstellung vor und ist danach in der Lage auch Objekte unmittelbar vor dem auszublendeten Hintergrund zu erfassen.

Wenn die grüne READY LED blinkt, ist die Erfassung fehlgeschlagen.

Datasensing S.r.l.

Strada S. Caterina 235 - 41122 Modena - Italy

Tel: +39 059 420411 - Fax: +39 059 253973 - www.datasensing.com

Die Gewährleistungsfrist für dieses Produkt beträgt 36 Monate. Für weitere Informationen siehe allgemeine Verkaufsbedingungen unter www.datasensing.com.



Informationen zur Entsorgung von Elektro- und Elektronik- Altgeräten (WEEE) erhalten Sie auf der Webseite www.datasensing.com.

© 2018 - 2022 Datasensing S.r.l. ♦ ALLE RECHTE VORBEHALTEN. ♦ Ohne die im Urheberrecht festgelegten Rechte einzuschränken, darf kein Teil dieses Dokuments ohne die ausdrückliche schriftliche Erlaubnis von Datasensing S.r.l., in einem Datenabfragesystem gespeichert oder eingeführt oder in irgendeiner Form, mittels irgendetwcher Methode oder für irgendetwelchen Zweck übermittelt werden. ♦ Datasensing und das Logo von Datasensing sind Handelsmarken von Datasensing S.r.l. ♦ ♦ Datasensing und das Logo von Datasensing sind Handelsmarken von Datasensing S.r.l. ♦



S5N-PA/MA...M

proximité suppression de fond

MANUEL D'INSTRUCTIONS



Les informations sur la communication IO-Link sont disponibles à la dernière page de ce manuel.

CONTRÔLES

LED DE SORTIE

La LED jaune allumée indique l'état de la sortie NO (normalement ouvert) fermé.

LED READY

La LED verte indique un fonctionnement normal. Si la LED verte clignote, l'acquisition a échoué. Veuillez vous référer au paragraphe "RÉGLAGE" pour les indications relatives à la procédure de configuration.

TOUCHE SET

La pression de ce bouton active la procédure de réglage.

INSTALLATION

S5N-PA...M: L'installation du capteur peut être effectuée grâce au filetage M18x1 du corps sur un trou débouchant (∅ 18mm) à l'aide de la rondelle appropriée et des deux écrous CH.24 (couple maximum de serrage 1.5Nm) fournis ou bien, grâce aux deux trous traversants du corps, au moyen de deux vis (M3x22 ou d'une longueur supérieure) dotées des rondelles de serrage.

Parmi les différentes combinaisons possibles choisir celle qui offre la meilleure visibilité des LED de signalisation et l'accès au bouton. Des écrous CH.22, h=8mm, (couple maxi de serrage 2Nm) sont disponibles en vue d'une plus grande force de serrage.

S5N-MA...M: L'installation du capteur peut être effectuée grâce au filetage M18x1 du corps sur un trou débouchant (∅ 18mm) à l'aide des deux écrous CH.24 (couple maximum de serrage 1.5Nm) fournis ou bien.

Des écrous ainsi que de nombreuses équerres orientables, en vue de faciliter le positionnement du capteur (voir accessoires au catalogue) sont disponibles soit pour le boîtier plastique que pour le boîtier métallique.



La distance opérationnelle est mesurée à partir de la surface frontale de la lentille du capteur.

En vue d'une meilleure détection, l'objet doit se déplacer, en s'approchant ou en s'éloignant de la surface des lentilles. En cas de translation latérale, l'objet doit se déplacer suivant l'indication reportée sur la figure.

CONNEXIONS

Les connexions sont configurées en conformité avec la norme EN 60947-5-2.

CONNECTEUR M12

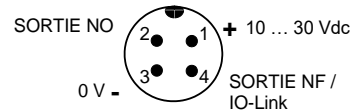

DIMENSIONS

VERSION S5N-PA

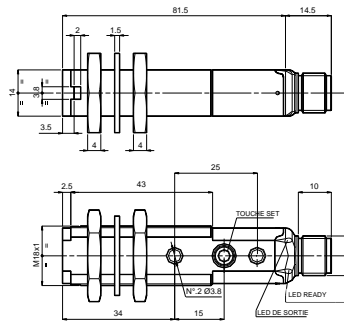

VERSION S5N-MA

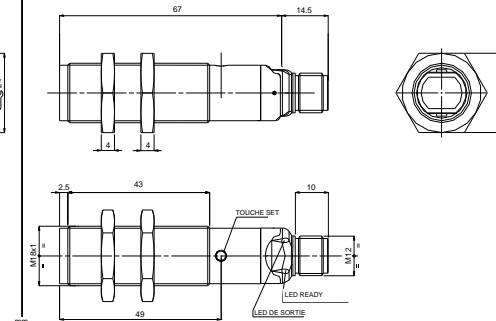

DONNEES TECHNIQUES

	VERSION PLASTIQUE S5N-PA	VERSION METALLIQUE S5N-MA
Alimentation:	10 ... 30 Vcc valeurs limites	
Ondulation:	2 Vpp max.	
Consommation (hors courant de sortie):	30 mA max.	
Sortie:	NO et NF; PNP ou NPN (protection contre le court-circuit)	
Courant de sortie:	100 mA max.	
Charge capacitive:	C _{max} ≤ 1.5 uF @24V, I _{load} = 100mA C _{max} ≤ 3.5 uF @24V, I _{load} = 10mA	
Tension de saturation en sortie:	2 V max.	
Temps de réponse:	1 ms	
Fréquence de commutation:	500 Hz	
Indicateurs:	LED DE SORTIE (JAUNE) / LED READY/ERROR (VERTE)	
Ajustement:	touche SET	
Mode opérationnel:	clair sur NO / sombre sur NF	
Mémoire:	mémoire EEPROM non volatile	
Température de fonctionnement:	-25 ... 55 °C	
Température de stockage:	-25 ... 70 °C	
Rigidité diélectrique:	500 Vca / 1 min. entre composants électroniques et boîtier	
Résistance d'isolement:	≥20 MΩ / 500 Vcc, entre composants électroniques et boîtier	
Distance de détection (valeurs typiques):	suppr. de fond 50...150 mm	
Type d'émission:	Rot (630 nm)	
Réjection à la lumière ambiante:	EN 60947-5-2	
Vibrations:	0.5 mm amplitude, 10 ... 55Hz fréquence, pour chaque axes (EN60068-2-6)	
Résistance aux chocs:	11 ms (30 G) 6 chocs pour chaque axes (EN60068-2-27)	
Boîtier:	PBT	laiton au nickelé
Lentilles:	PMMA	
Classe de protection:	IP67 Boîtier type 1, versions en métal	
Connexions:	connecteur M12 4-pôles	
Poids:	25 g. max versions connecteur	60 g. max versions connecteur
AtEx 2014/34/EU	II 3G EX nA II T6 ; II 3D EX tD A22 IP67 T85°C	
Émissions:	Groupe de risque exempté (RG 0) selon IEC 62471	

REGLAGES

EASY TOUCH™

Le détecteur utilise la technologie brevetée du mode d'apprentissage *EASY TOUCH™*. Il permet un paramétrage rapide et sûr du produit.

Deux modes de réglages sont possibles:

- *EASY TOUCH™*, en appuyant sur la touche SET de manière prolongée, on obtient une acquisition standard.
- *ACQUISITION FINE*, à utiliser uniquement dans des conditions particulières lorsque le mode *EASY TOUCH™* s'est avéré insuffisant.

Réglage S5N-PA/MA...M

Pour un réglage correcte de cette version, il faut durant l'apprentissage détecter l'arrière plan ou l'objet à NE PAS détecter.

- *EASY TOUCH™ (Acquisition standard)*

Positionner, à l'intérieur de la distance de détection, l'arrière plan ou l'objet à NE PAS détecter.

Appuyer sur la touche SET jusqu'à l'extinction de la LED verte READY (1s).

Relâcher la touche SET et la LED READY s'allume de nouveau.

Le détecteur peut à présent détecter n'importe quel objet dans le champs de détection par rapport à l'arrière plan.

- *Acquisition fine*

Positionner dans le champs de détection, l'arrière plan ou l'objet à NE PAS détecter.

Appuyer sur la touche SET jusqu'à l'extinction de la LED READY et la maintenir appuyée jusqu'à ce que la LED verte READY s'allume de nouveau (3s).

le détecteur se met en réglage fin et peut détecter les objets qui se distinguent difficilement de l'arrière plan.

Si la LED verte clignote, l'acquisition a échoué.

Datasensing S.r.l.

Strada S. Caterina 235 - 41122 Modena - Italy
Tel: +39 059 420411 - Fax: +39 059 253973 - www.datasensing.com

La période de garantie pour ce produit est de 36 mois. Voir les Conditions Générales de Vente sur www.datasensing.com pour plus de détails.



Pour toute information relative à l'élimination des déchets électroniques (WEEE), veuillez consulter le site internet www.datasensing.com.

© 2018 – 2021 Datasensing S.r.l. ♦ TOUS DROITS RÉSERVÉS. ♦ Aucune partie de cette documentation ne peut être reproduite, stockée ou introduite dans un système de recherche, ni transmise sous quelque forme ou par quelque moyen que ce soit, ni à quelque fin que ce soit, sans l'autorisation écrite expresse de Datasensing S.r.l. ♦ Datasensing et le logo Datasensing sont des marques de commerce de Datasensing S.r.l. ♦ ♦ Datasensing et le logo Datasensing sont des marques de commerce de Datasensing S.r.l. ♦



S5N-PA/MA...M

Tasteggio a soppressione di sfondo

MANUALE ISTRUZIONI



Le informazioni relative alla comunicazione IO-Link sono disponibili nell'ultima pagina del presente manuale.

CONTROLLI

LED DI USCITA

Il LED giallo acceso indica lo stato dell'uscita N.A. (normalmente aperto) chiusa.

LED READY

Il LED verde acceso indica lo stato di funzionamento normale.

Se il LED verde READY lampeggia, l'acquisizione è fallita.

Fare riferimento al paragrafo "REGOLAZIONI" per le indicazioni durante le procedure di acquisizione.

TASTO SET

La pressione prolungata del tasto attiva la procedura di impostazione in autoapprendimento.

INSTALLAZIONE

S5N-PA...M: L'installazione del sensore può essere effettuata grazie alla filettatura M18x1 del corpo su foro passante (\varnothing 18 mm) utilizzando l'apposita rondella ed i due dadi CH.24 (coppia max. di serraggio 1.5 Nm) in dotazione oppure, grazie ai due fori passanti del corpo, tramite due viti (M3x22 o di maggiore lunghezza) con rondelle di serraggio. Tra le varie combinazioni possibili scegliere quella che offre la maggiore visibilità dei LED di segnalazione e l'accesso al tasto. Sono disponibili dadi CH.22, h=8 mm, (coppia max. di serraggio 2 Nm) per una maggiore forza di serraggio.

S5N-MA...M: L'installazione del sensore può essere effettuata grazie alla filettatura M18x1 del corpo su foro passante (\varnothing 18 mm) utilizzando i due dadi CH.24 (coppia max. di serraggio 22 Nm) in dotazione.

Sia per la versione plastica che metallica sono disponibili numerose staffe orientabili per facilitare il posizionamento del sensore (vedi accessori a catalogo).

La distanza operativa è misurata a partire dalla superficie frontale della lente del sensore.

Per una migliore rilevazione, l'oggetto deve muoversi in avvicinamento od allontanamento da tale superficie.

In caso di traslazione laterale, l'oggetto si deve muovere come indicato in figura.



CONNESSIONI

Le connessioni sono configurate in conformità con la norma EN 60947-5-2.

CONNETTORE M12

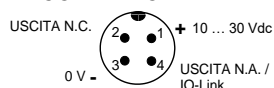

DIMENSIONI D'INGOMBRO

VERSIONE S5N-PA

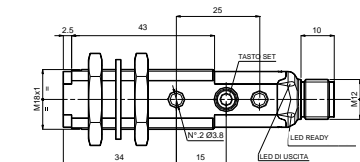
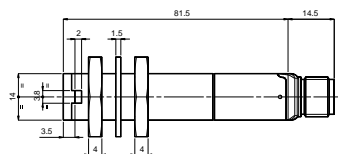

VERSIONE S5N-MA

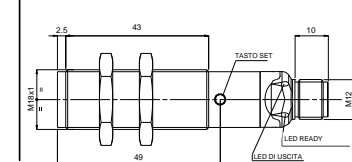
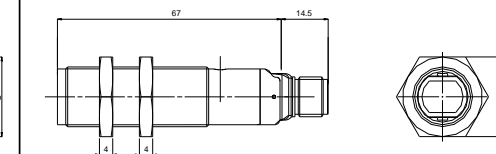

DATI TECNICI

	VERSIONE PLASTICA S5N-PA	VERSIONE METALLICA S5N-MA
Tensione di alimentazione:	10 ... 30 Vcc valori limite	
Tensione di ripple:	2 Vpp max.	
Assorbimento (esclusa corrente di uscita):	30 mA max.	
Uscite:	N.A. e N.C.; PNP o NPN (protezione contro il cortocircuito)	
Corrente di uscita:	100 mA max.	
Carico capacitivo:	C _{max} ≤ 1.5 uF @24V, I _{load} = 100mA C _{max} ≤ 3.5 uF @24V, I _{load} = 10mA	
Tensione di saturazione dell'uscita:	2 V max.	
Tempo di risposta:	1 ms	
Frequenza di commutazione:	500 Hz	
Indicatori:	LED DI USCITA (GIALLO) / LED READY (VERDE)	
Impostazione:	tasto SET	
Modalità operativa:	modo LUCE su uscita N.A. / modo BUIO su uscita N.C.	
Ritenzione dati:	memoria non volatile EEPROM	
Temperatura di funzionamento:	-25 ... 55 °C	
Temperatura di immagazzinamento:	-25 ... 70 °C	
Rigidità dielettrica:	500 Vca 1 min tra parti elettroniche e contenitore	
Resistenza d'isolamento	>20 MΩ 500 Vcc tra parti elettroniche e contenitore	
Distanza operativa (valori tipici):	soppr. di sfondo 50...150 mm	
Tipo di emissione:	rossa (630 nm)	
Reiezione alla luce ambiente:	come prescritto da EN 60947-5-2	
Vibrazioni:	ampiezza 0.5 mm, frequenza 10 ... 55 Hz, per ogni asse (EN60068-2-6)	
Resistenza agli urti:	11 ms (30 G) 6 shock per ogni asse (EN60068-2-27)	
Materiale contenitore:	PBT	Ottone nichelato
Materiale lenti:	PMMA	
Protezione meccanica:	IP67 Contenitore tipo 1, versioni metalliche	
Collegamenti:	connettore M12 a 4 poli	
Peso:	25 g. max. vers. a conn.	60 g. max. vers. a conn.
AtEx 2014/34/EU	I 1 3G EX nA II T6 ; I 1 3D EX tD A22 IP67 T85°C	
Emissioni:	Gruppo di rischio esente (RG 0) secondo IEC 62471	

REGOLAZIONI

EASY TOUCH™

Il sensore utilizza la tecnologia brevettata EASY TOUCH™ che permette una rapida e sicura impostazione del prodotto in autoapprendimento.

Sono previste due diverse possibilità di impostazione:

- **EASY TOUCH™**, con una sola pressione prolungata del tasto SET si ottiene la regolazione in autoapprendimento.
- **ACQUISIZIONE FINE**, da utilizzarsi solamente in condizioni particolarmente critiche. Si accede a questa modalità operativa solamente qualora l'EASY TOUCH™ non sia risultato sufficiente.

Impostazione S5N-PA/MA...M

Per settare correttamente questa versione, durante l'autoapprendimento è sempre necessario rilevare lo sfondo o comunque l'oggetto che NON si vuole rilevare.

- EASY TOUCH™ (acquisizione standard)

Posizionare, entro la distanza operativa, lo sfondo o l'oggetto che NON deve essere rilevato.

Premere il tasto SET fino allo spegnimento del LED READY (1s).

Rilasciare il tasto SET ed attendere l'accensione del LED READY.

Il sensore è ora pronto a rilevare qualunque oggetto nel campo operativo rispetto allo sfondo.

- Acquisizione fine

Posizionare, entro la distanza operativa, lo sfondo o l'oggetto che NON deve essere rilevato.

Premere il tasto SET e mantenerlo premuto fino all'accensione del LED READY (3s).

Il sensore attua in questo caso, una taratura fine ed è pronto alla rilevazione di oggetti che si discostano minimamente dallo sfondo.

Se il LED verde READY lampeggia, l'acquisizione è fallita.

Datasensing S.r.l.

Strada S. Caterina 235 - 41122 Modena - Italy

Tel: +39 059 420411 - Fax: +39 059 253973 - www.datasensing.com

Il periodo di garanzia per questo prodotto è di 36 mesi. Per maggiori dettagli vedere Condizioni Generali di Vendita su www.datasensing.com.



Per informazioni sullo smaltimento delle apparecchiature elettriche ed elettroniche (WEEE) consultare il sito Web www.datasensing.com.

© 2018 - 2022 Datasensing S.r.l. • TUTTI I DIRITTI RISERVATI. • Senza con ciò limitare i diritti coperti dal copyright, nessuna parte della presente documentazione può essere riprodotta, memorizzata o introdotta in un sistema di recupero o trasmessa in qualsiasi forma o con qualsiasi mezzo, o per qualsiasi scopo, senza l'espresso consenso scritto di Datasensing S.r.l. • Datasensing e il logo Datasensing sono marchi di Datasensing S.r.l. • Datasensing e il logo Datasensing sono marchi di Datasensing S.r.l. ♦



S5N-PA/MA...M

背景抑制邻近

说明手册



有关 IO-Link 通信的信息，请参阅本手册最后一页。

控制

输出 LED

黄色 LED 亮起表示 N.O. (常开) 输出状态为已关闭。

就绪 LED

绿色 LED 表示正常运行功能。
如果绿色 LED 闪烁，则采集失败。
请参阅“设置”段落了解设置步骤指示。

SET 按钮

长按按钮可激活自设置步骤。

安装

S5N-PA...M: 使用带两个封闭式 CH.24 螺母的专用垫圈 (最大拧紧扭矩 1.5 Nm)，可以通过 M18x1 螺纹体经 $\varnothing 18$ mm 孔将传感器固定。或者，可以使用两个螺钉 (M3x22 或更长) 和垫圈通过外壳的两个孔安装传感器。

在各种可能的解决方案中，我们建议选择能够提供信号 LED 的最佳可见性和最方便使用 SET 按钮的组合。

22 mm 螺母、h=8 mm (2 Nm 最大拧紧扭矩) 可用于保证更高的扭矩。

S5N-MA...M: 使用两个封闭式 CH.24 螺母 (最大拧紧扭矩 22 Nm)，可以通过 M18x1 螺纹体经 $\varnothing 18$ mm 孔将传感器固定。

对于塑料版本和金属版本，各种可定向固定支架可用于简化传感器定位 (请参阅总目录中列出的附件)。

从传感器镜头的前表面开始测量工作距离。

为提高检测效率，必须使物体靠近或远离传感器镜头的前表面。

在横向平移的情况下，物体必须按如图所示方式移动。



连接

连接符合 EN 60947-5-2 标准。

M12 连接器

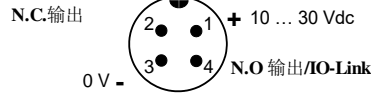

尺寸

S5N-PA 版本

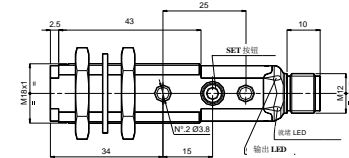
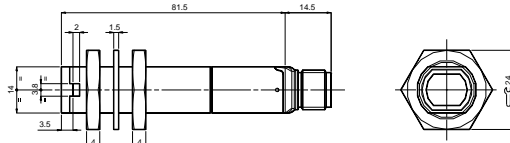

S5N-MA 版本

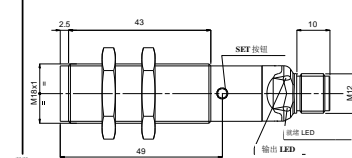
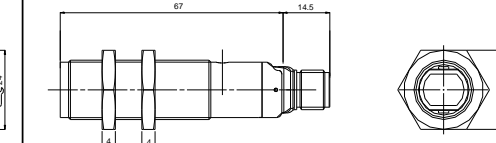

技术数据

	S5N-PA 塑料版本	S5N-MA 金属版本
电源:	10 ... 30 Vdc (极限值)	
纹波:	最大 2 Vpp	
电流消耗 (不包括输出电流):	最大 30 mA。	
输出:	N.A. 和 N.C.: PNP 或 NPN (短路保护)	
输出电流:	最大 100 mA。	
电容性负载:	C _{max} ≤ 1.5 uF @24V, I _{load} = 100mA C _{max} ≤ 3.5 uF @24V, I _{load} = 10mA	
输出饱和电压:	最大 2 V。	
响应时间:	1 ms	
开关频率:	500 Hz	
指示灯:	输出 LED (黄色) / 就绪 LED (绿色)	
设置:	SET 按钮	
工作模式:	N.O. 输出时为 LIGHT 模式/N.C. 输出时为 DARK 模式	
数据保留:	非易失性 EEPROM 存储器	
工作温度:	-25 ... 55 °C	
储存温度:	-25 ... 70 °C	
绝缘强度:	500 Vac 1 min., 电子设备与外壳之间	
绝缘电阻:	>20 MΩ 500 Vdc, 电子设备与外壳之间	
工作距离 (典型值):	背景抑制 50...150 mm	
发射类型:	红色 (630 nm)	
环境光抑制:	符合 EN 60947-5-2	
振动:	每个轴 0.5 mm 振幅, 10 ... 55 Hz 频率 (EN60068-2-6)	
抗冲击性:	每个轴 11 ms (30 G) 6 次冲击 (EN60068-2-27)	
外壳材料:	PBT	镀镍黄铜
镜头材料:	PMMA	
机械保护:	IP67 金属版本 1 型外壳	
连接:	M12 - 4 针连接器	
重量:	连接器版本最大 25 g.	连接器版本最大 60 g.
AtEx 2014/34/EU	I I 3G EX nA II T6 ; I I 3D EX tD A22 IP67 T85 °C	
发射:	免除风险组 (RG0) 符合 IEC 62471	

设置

EASY TOUCH™

传感器使用获得专利的 EASY TOUCH™ 技术，可对产品进行快速安全的自设置。

提供两种不同的设置可能性:

- EASY TOUCH™: 长按 SET 按钮可进行自设置。
- 精细检测: 仅在特别关键的情况下使用; 此设置步骤仅在 EASY TOUCH™ 不充分时使用。

S5N-PA/MA...M 设置

为实现正确的传感器设置，自设置期间必须存在背景或要抑制的物体。

- EASY TOUCH™ (标准检测)

将背景或要抑制的物体放在工作范围内。

按下 SET 按钮，直到就绪 LED 熄灭 (1s)。

松开 SET 按钮，等待就绪 LED 亮起。

传感器现在准备好检测设置范围内的所有物体，从而将其与抑制背景区分开。

- 精细检测

将背景或要抑制的物体放在工作范围内。

按下 SET 按钮。就绪 LED 熄灭。

按住 SET 按钮，直到就绪 LED 亮起 (3s)。

传感器会进行微调，并准备好检测也非常靠近抑制背景的物体。

如果绿色 LED 闪烁，则采集失败。

Datasensing S.r.l.

Strada S. Caterina 235 - 41122 Modena - Italy

电话: +39 059 420411 - 传真: +39 059 253973 - www.datasensing.com

本产品的保修期为 36 个月。有关详细信息，请参阅“一般销售条款和条件”。



有关处置报废电子电气设备 (WEEE) 的信息，请参阅网站 www.datasensing.com。

© 2018 - 2022 Datasensing S.r.l. ◆ 保留所有权利。◆ 在不限版权所有权，或未经 Datasensing S.r.l. 的书面许可的情况下，不得对此文档的任何一部分进行复制、存储或将其引入检索系统，不得以任何形式、通过任何方法对此文档进行传播，不得将此文档用于任何目的。◆ Datasensing 和 Datasensing 徽标是 Datasensing S.r.l. 的商标。◆ Datalogic 和 Datalogic 标志是 Datalogic S.p.A. 在美国和欧盟等诸多国家或地区的注册商标。



S5N

IO-Link® parameters

PHYSICAL LAYER

Description	
IO-Link Revision	1.1
SIO Modus	YES
Min Cycle Time	5 ms (LED models) / 8 ms (Laser models)
Transmission Rate	38,4 kbit/s (COM2)
Process Data Length	PDInput: 24 Bit PDOOutput: 1 Bit
M-Sequence Capability	PREOPERATE: TYPE_0 OPERATE: TYPE_2_V ISDU: supported

FEATURES

Description	
Block Parameter	YES
Data Storage	YES
Supported Access Locks	Parameter (write) access Data Storage
Profile Characteristic	Device Profile: Smart Sensor Function Class: Device Identification Function Class: Binary Data Channel Function Class: Process Data Variable Function Class: Device Diagnosis Function Class: Teach Channel Function Class: Teach-in Single Value Function Class: Transducer Disable

SERVICE DATA

The following ISDUs will not be saved via Data Storage: Device Access Locks (index 0xC), Teach-in Channel (index 0x3A), Adjustment Mode (index 0x66)

System Parameters							
Index (dec)	Parameter Object Name	Lenght	Subindex (offset)	Value/Range	Description	Data Type	Access*
0x000C (12)	Device Access Locks	2 octets		Bit 1: Data Storage (0 = unlocked, 1 = locked)	Standardized Device locking functions: Bit 0: Parameter (write) access (not used) Bit 1: Data Storage Bit 2: Local parameterization (Not used) Bit 3: Local user interface (Not used) Bit 4-15: Reserved	RecordT	R/W
0x000D (13)	Profile Characteristics	2 octets 2 octets 2 octets 2 octets 2 octets 2 octets 2 octets		0x0001 0x8000 0x8001 0x8002 0x8003 0x8004 0x8007 0x800C	Smart Sensor Profile Device Identification Binary Data Channel (BDC) Process Data Variable (PDV) Device Diagnosis Teach Channel Teach-in single value Transducer Disable	ArrayT of UIntegerT16	RO
0x000E (14)	PDInput Descriptor	3 octets 3 octets 3 octets 3 octets		0x01.0x01.0x00 0x01.0x01.0x01 0x01.0x01.0x02 0x01.0x01.0x03 0x02.0x10.0x08	SSC1 (OUT0) SSC2 (OUT1) TEACH STATUS FLAG STABILITY (C01) / ALARM (B01) PDV1 (NORMALIZED DISTANCE (M03) / LIGHT RECEIVED (W03, B01, C01, T01))	ArrayT of OctetStringT3	RO
0x000F (15)	PDOOutput Descriptor	3 octets		0x01.0x01.0x00	TRANSDUCER DISABLE	ArrayT of OctetStringT3	RO

*RO = read only, WO = write only, R/W = read/write

Identification Parameters								
Index (dec)	Parameter Object Name	Length	Subindex (offset)	Value/Range	Description	Data Type	Access*	Remark
0x0010 (16)	Vendor Name	9 octets		DATALOGIC	Informative	StringT	RO	
0x0011 (17)	Vendor Text	19 octets		Empower your vision		StringT	RO	
0x0012 (18)	Product Name	15 octets		See "Device variant collection" on page 5	Detailed product name	StringT	RO	
0x0013 (19)	Product ID	5 octets		See "Device variant collection" on page 5	Product identification	StringT	RO	
0x0014 (20)	Product Text	21 octets		See "Device variant collection" on page 5		StringT	RO	
0x0015 (21)	Serial Number	9 octets			Unique serial number	StringT	RO	
0x0016 (22)	Hardware Revision	5 octets		RevAE		StringT	RO	
0x0017 (23)	Firmware Revision	5 octets		5.0.0		StringT	RO	
0x0018 (24)	Application Specific Tag	32 octets		*** (default)	Tag application defined by user	StringT	R/W	Saved in non-volatile memory
0x0019 (25)	Function Tag	32 octets		*** (default)	Additional tag for device function identification	StringT	R/W	Saved in non-volatile memory
0x001A (26)	Location Tag	32 octets		*** (default)	Additional tag for device function identification	StringT	R/W	Saved in non-volatile memory

Observation / Diagnostic Parameters								
Index (dec)	Parameter Object Name	Length	Subindex (offset)	Value/Range	Description	Data Type	Access*	Remark
0x0028 (40)	Process Data Input	3 octets			Read last valid Process Data Input from PDin channel	Device specific	RO	
0x0029 (41)	Process Data Output	1 octet			Read last valid Process Data Output from PDout channel	Device specific	RO	
0x0052 (82)	Device Temperature	2 octets 2 octets 2 octets 2 octets 2 octets	1(64) 2(48) 3(32) 4(16) 5(0)		Device temperature actual Device min. temperature since powerup Device max. temperature since powerup Device min. temperature during lifetime Device max. temperature during lifetime	IntegerT IntegerT IntegerT IntegerT IntegerT	RO RO RO RO RO	
0x0053 (83)	Device Temperature Threshold	2 octets 2 octets	1(16) 2(0)		Device min. temperature threshold (B01, C01, T01) Device max. temperature threshold (B01, C01, T01)	IntegerT IntegerT	R/W	Saved in non-volatile memory every hour. Events are generated if the device temperature exceeds the thresholds.
0x0057 (87)	Operating Hours	4 octets 4 octets 4 octets	1(64) 2(32) 3(0)	0...(2^32)-1	Operating Hours: device operating hours. Not resettable by user. Operating Hours Maintenance: device operating hours, reset on system command "Confirm Maintenance". Operating Hours Power Up: Time in hours since power up.	UIntegerT UIntegerT UIntegerT	RO RO RO	
0x0024 (36)	Device Status	1 octet		0x00 → Device is operating properly 0x01 → Maintenance Required 0x02 → Out of specification 0x03 → Functional Check 0x04 → Failure	Contains current status of the device	UIntegerT	RO	
0x0025 (37)	Detailed Device Status	3 octets			Information about currently pending Events. Implemented as dynamic list.	UIntegerT	RO	
0x00BE (190)	Excess gain	2 octets		100...900	Excess gain (EG) = 0 if signal is under threshold (B01 LED, C01, T01)	UIntegerT	RO	

*RO = read only, WO = write only, R/W = read/write

Teach-in Parameters								
Index (dec)	Parameter Object Name	Lenght	Subindex (offset)	Value/Range	Description	Data Type	Access*	Remark
0x003A (58)	TI Select	1 octet		0x00 = SSC1 (default, C/Q pin and DO pin)	Selection for Teach-in channel (volatile)	UIntegerT	R/W	C/Q and DO outputs are antivalent. Teach SSC1 equals to teach SSC2
0x003B (59)	TI Result	1 octet	1(0) 2(4) 3(5)	Teach-in State Flag SP1 TP1 Flag SP2 TP1	See IO-Link Smart Sensor Profile	UIntegerT4 BooleanT BooleanT	RO	
0x003C (60)	SSC1 Param	2 octets 2 octets	1(16) 2(0)	0-4095 Not used	Normalized distance (M03) / Switching threshold (W03) / Trimmer value (sensitivity adjustment) (Trimmer models)	UIntegerT	R/W	Saved in non-volatile memory
0x003D (61)	SSC1 Config	1 octet	1(24)	0x00: High Active (default C01, M03, W03) 0x01: Low Active (default B01, T01)	C/Q pin configuration	UIntegerT	R/W	Saved in non-volatile memory
		1 octet	2(16)	0x01: Single Point (default)		UIntegerT		
		2 octets	3(0)	Not used (M03) 0 ..10 Hysteresis (W03) 0 - 1 Hysteresis (Trimmer models)		UIntegerT		
0x003E (62)	SSC2 Param	2 octets 2 octets	1(16) 2(0)	0-4095 Non used	Normalized distance	UIntegerT	R/W	Saved in non-volatile memory
0x003F (63)	SSC2 Config	1 octet	1(24)	0x00: High Active (default B01, T01) 0x01: Low Active (default C01, M03, W03)	DO pin configuration	UIntegerT	R/W	Saved in non-volatile memory
		1 octet	2(16)	0x01: Single Point (default)		UIntegerT		
		2 octets	3(0)	Not used (M03) 0 ..10 Hysteresis (W03) 0 - 1 Hysteresis (Trimmer models)		UIntegerT		
0x0066 (102)	Adjustment mode	1 octet		0x00 = manual (default) 0x01 = IO-Link	Status of trimmer regulation (manual/IO-Link) (B01, C01, T01)	BooleanT	R/W	

*RO = read only, WO = write only, R/W = read/write

Device Specific Parameters								
Index (dec)	Parameter Object Name	Length	Subindex (offset)	Value/Range	Description	Data Type	Access*	Remark
0x0048 (72)	Delay Settings	1 octet	1(64)	0 = no delay (default) 0x2 = Delay ON 0x3 = One Shot 0x4 = Delay OFF	Select Delay mode (ON / OFF/ ONE SHOT)	UIntegerT	R/W	Saved in non-volatile memory
		4 octets	2(32)	0...(2^32)-1	Delay ON value = Delay [ms] *1000 / 141 (M03) Delay [ms] *1000 / 45 (W03) Delay [ms] *1000 / 157 (T01/C01/B01 LED emission) Delay [ms] *1000 / 67 (C01 Laser) Delay [ms] *1000 / 70 (B01 Laser)	UIntegerT	R/W	
		4 octets	3(0)	0...(2^32)-1	Delay OFF value = Delay [ms] *1000 / 141 (M03) Delay [ms] *1000 / 45 (W03) Delay [ms] *1000 / 157 (T01/C01/B01 LED emission) Delay [ms] *1000 / 67 (C01 Laser) Delay [ms] *1000 / 70 (B01 Laser)	UIntegerT	R/W	
0x00B4 (180)	Output type	1 octet	1(8)	0x01 = PNP (default) 0x03 = Push Pull ⁽¹⁾	Output type of C/Q pin when in SIO mode	UIntegerT	R/W	Saved in non-volatile memory
		1 octet	2(0)	0x01 = PNP (default) 0x02 = NPN 0x03 = Push Pull	Output type of DO pin	UIntegerT	R/W	

⁽¹⁾ The No Output configured in Push Pull mode with an NPN load does not reactivate after a short circuit condition. Remove the short circuit condition and cycle power to the sensor.

Standard Command						
Index (dec)	Command Name	Length	Value (dec)	Description	Access*	
0x0002 (2)	SP1 Single Value Teach	1 octet	0x41 (65)	Acquisition EASY (refer to User's Manual) (M03, W03) / Teach Set Point (B01, C01, T01)	WO	
0x0002 (2)	SP1 Teach TP1	1 octet	0x43 (67)	Acquisition FINE: Mark Detection (refer to User's Manual) (W03)	WO	
0x0002 (2)	SP1 Teach TP2	1 octet	0x44 (68)	Acquisition FINE: Background Detection (refer to User's Manual) (W03)	WO	
0x0002 (2)	Teach FINE	1 octet	0x4B (75)	Acquisition FINE (refer to User's Manual) (M03)	WO	
0x0002 (2)	Teach CANCEL	1 octet	0x4F (79)	Exit from teach FAIL status (M03) / Exit from Fine detection (W03)	WO	
0x0002 (2)	Restore Factory Settings	1 octet	0x82 (130)	Restore factory settings (Device Access Locks, Application Specific Tag, Function Tag, Location Tag, SSC1 Param, SSC2 Param, Delay Settings, Output Type, Adjust Mode)	WO	
0x0002 (2)	Confirm Maintenance	1 octet	0xA5 (165)	Reset Maintenance parameters (Operating Hours Maintenance, Minimum device temperature since powerup, Maximum device temperature since powerup, Device Status, Detailed Device Status)	WO	
0x0002 (2)	Disable IO-Link adjustment	1 octet	0xAB (171)	Disable teach via IO-Link, re-enable trimmer adjustment (B01, C01, T01)	WO	
0x0002 (2)	Start / Stop Ping	1 octet	0xAF (175)	Feature to identify the sensor by yellow led blinking	WO	

Events					
Event code (dec)	Event name	Event mode	Event type	Device status	Remarks
0x4220 (16928)	Temperature underrun	Appears / Disappears	Warning	Out of specification	only B01, C01, T01
0x4210 (16912)	Temperature overrun	Appears / Disappears	Warning	Out of specification	
0x5100 (20736)	General power supply fault	Appears / Disappears	Error	Failure	
0x7710 (30480)	Short circuit - Check installation	Appears / Disappears	Error	Failure	
0x8C40 (35904)	Maintenance required - Lens cleaning	Appears / Disappears	Notification	Maintenance required	only B01
0x8CA0 (36000)	Laser fault	Appears / Disappears	Error	Failure	only Laser models

PROCESS DATA

Process Data Output							
Byte 0							
7	6	5	4	3	2	1	0
Not used							TRANSDUCER DISABLE
Process Data Input							
Byte 2							
23	22	21	20	19	18	17	16
PDV1 (Normalized distance (M03) ⁽²⁾ / LIGHT RECEIVED (W03, B01, C01, T01) (MSB))							
Byte 1							
15	14	13	12	11	10	9	8
PDV1 (Normalized distance (M03) ⁽²⁾ / LIGHT RECEIVED (W03, B01, C01, T01) (LSB))							
Byte 0							
7	6	5	4	3	2	1	0
Not used				Not used (W03, M03, T01), Stability (C01) Alarm (B01)	TEACH-IN	SSC2 (DO pin)	SSC1 (C/Q pin)

⁽²⁾ Process data will not be valid in case of out-of-range values.

DEVICE VARIANT COLLECTION

Product name	Product ID	Product text	Device ID
S5N-PA-5-C01-OZ	02210	Diffuse proximity	2
S5N-MA-5-C01-OZ	22200	Diffuse proximity	
S5N-PA-5-M03-OZ	02230	Background suppression	3
S5N-MA-5-M03-OZ	22170	Background suppression	
S5N-PA-5-W03-OZ	02240	Mark reader	4
S5N-PL-5-C01-OZ	02260	Diffuse proximity laser	5
S5N-ML-5-C01-OZ	22190	Diffuse proximity laser	
S5N-PL-5-B01-OZ	02250	Reflex polarized laser	6
S5N-ML-5-B01-OZ	22180	Reflex polarized laser	
S5N-PA-5-B01-OZ	02200	Reflex polarized	7
S5N-MA-5-B01-OZ	22160	Reflex polarized	
S5N-PA-5-T01-OZ	02220	Reflex transparent	8

EN	CE Compliance
<p>CE marking states the compliance of the product with essential requirements listed in the applicable European directive. Since the directives and applicable standards are subject to continuous updates, and since the manufacturer promptly adopts these updates, therefore the EU declaration of conformity is a living document. The EU declaration of conformity is available for competent authorities and customers through the manufacturer's commercial reference contacts. Since April 20th, 2016 the main European directives applicable to the products require inclusion of an adequate analysis and assessment of the risk(s). This evaluation was carried out in relation to the applicable points of the standards listed in the Declaration of Conformity. These products are mainly designed for integration purposes into more complex systems. For this reason, it is under the responsibility of the system integrator to do a new risk assessment regarding the final installation.</p> <p>Warning This is a Class A product. In a domestic environment this product may cause radio interference in which case the user may be required to take adequate measures.</p>	

IT	Conformità CE
<p>La marcatura CE dichiara la conformità del prodotto con i requisiti essenziali elencati nella direttiva europea applicabile. Essendo le direttive e le normative applicabili soggette a continui aggiornamenti, e dato che il costruttore adotta immediatamente tali aggiornamenti, la dichiarazione di conformità CE è un documento vivo. La dichiarazione di conformità CE è disponibile per le autorità competenti e i clienti tramite i contatti commerciali di riferimento al costruttore. Dal 20 aprile 2016, le principali direttive europee applicabili ai prodotti richiedono l'inserimento di un'adeguata analisi e valutazione dell/i rischi(o). Tale valutazione è stata realizzata in relazione ai punti applicabili delle normative elencate nella Dichiarazione di Conformità. Questi prodotti sono progettati principalmente per essere integrati in sistemi più complessi. Per questo motivo, l'integratore di sistemi è responsabile della realizzazione di una nuova valutazione dei rischi riguardante l'installazione finale.</p> <p>Attenzione Si tratta di un prodotto di Classe A. In un ambiente domestico questo prodotto può generare interferenze radio. In tal caso è necessario prendere le dovute misure.</p>	

DE	EG-Konformität
<p>Die CE-Kennzeichnung bestätigt die Konformität des Produkts mit den wesentlichen Anforderungen der geltenden europäischen Richtlinien. Da die Richtlinien und anwendbaren Normen laufend aktualisiert werden und der Hersteller diese Aktualisierungen umgehend übernimmt, ist die EU-Konformitätserklärung ein fortschreitendes Dokument. Die EU-Konformitätserklärung ist für zuständige Behörden und Kunden über die Handelskontakte von dem Hersteller erhältlich. Seit dem 20. April 2016 erfordern die wichtigsten für diese Produkte anwendbaren Europäischen Richtlinien die Integration einer angemessenen Analyse und der Bewertung der Risiken. Diese Bewertung wird in Bezug auf die anwendbaren Punkte der in der Konformitätserklärung aufgelisteten Normen durchgeführt. Diese Produkte werden in erster Linie für die Integration in komplexere Systeme ausgelegt. Aus diesem Grund liegt es in der Verantwortung des Systemintegrators, eine neue Risikobewertung der Endinstallation vorzunehmen.</p> <p>Warnung Dies ist ein Produkt nach Klasse A. In einem häuslichen Umfeld kann dieses Produkt Funkstörungen auslösen, gegebenenfalls hat der Benutzer dann angebrachte Maßnahmen zu ergreifen.</p>	

FR	Conformité CE
<p>La marque CE indique la conformité du produit aux exigences essentielles énoncées dans la directive européenne applicable. Les directives et les normes applicables sont sujettes à des mises à jour de manière continue et le constructeur adopte rapidement ces mises à jour ; la déclaration de conformité UE est par conséquent un document vivant. La déclaration de conformité UE est disponible aux autorités compétentes et aux clients à travers les interlocuteurs commerciaux de référence des constructeurs. Depuis le 20 Avril 2016 les principales directives européennes applicables aux produits exigent l'inclusion d'une analyse et d'une évaluation adéquates du/des risque/s. Cette évaluation a été réalisée en relation avec les points applicables des normes indiquées dans la Déclaration de Conformité. Ces produits sont principalement conçus à des fins d'intégration dans des systèmes plus complexes. Pour cette raison, il est de la responsabilité de l'intégrateur de système d'effectuer une nouvelle évaluation des risques concernant l'installation finale.</p> <p>Avertissement Ceci est un produit de Classe A. Dans un environnement domestique, ce produit peut provoquer des interférences radio auquel cas l'utilisateur peut se trouver dans l'obligation de prendre des mesures adéquates.</p>	

ES	Conformidad CE
<p>La marca CE establece la conformidad del producto con los requisitos fundamentales enumerados en la directiva europea aplicable. Debido a que las directivas y normativas aplicables están sujetas a actualización continua, como el constructor adopta estas actualizaciones de inmediato, la declaración de conformidad UE es un documento activo. La declaración de conformidad UE está disponible para las autoridades competentes y para los clientes a través de los contactos comerciales de referencia del constructor. Desde el 20 de abril de 2016, las principales directivas europeas aplicables a los productos exigen la inclusión de un idóneo análisis y evaluación de riesgos. Esta evaluación ha sido efectuada sobre los puntos aplicables de la normativa indicada en la Declaración de Conformidad. Estos productos han sido diseñados a fin de ser integrados en sistemas más complejos. Por ello, es responsabilidad del integrador del sistema efectuar una nueva evaluación de riesgos relativa a la instalación final.</p> <p>Advertencia Este es un producto de Clase A. En un entorno doméstico, este producto puede causar interferencias radioeléctricas; en este caso, el usuario debería tomar medidas adecuadas.</p>	

NL	EU-conformiteitsverklaring
<p>Met de CE-markering wordt verklaard dat het product voldoet aan de essentiële eisen zoals vermeld in de toepasselijke Europese richtlijnen. Daar de richtlijnen en de toepasselijke normen onderhevig zijn aan voortdurende aanpassingen, en de fabrikant deze aanpassingen direct toepast, is de EU-conformiteitsverklaring een levend document. De EU-conformiteitsverklaring is beschikbaar voor bevoegde autoriteiten en klanten via contactgegevens voor commerciële referentie. Sinds 20 april 2016 vereisen de belangrijkste Europese richtlijnen de inclusie van een adequate risicoanalyse- en beoordeling. Deze beoordeling werd uitgevoerd met betrekking tot de toepasselijke punten van de normen zoals vermeld in de Conformiteitsverklaring. Deze producten zijn voornamelijk ontworpen voor integratie in complexere systemen. Om deze reden is het de verantwoordelijkheid van de systeemintegrator om een nieuwe risicobeoordeling uit te voeren met betrekking tot de definitieve installatie.</p> <p>Waarschuwing Dit is een Klasse A product. In een woonomgeving kan dit product radiostoring veroorzaken, in welk geval de gebruiker mogelijk verplicht is om adequate maatregelen te treffen.</p>	

S5N-PL/ML SERIES INSTRUCTION MANUAL



Information on IO-Link communication is available on the last page of this manual.



IEC 60825-1 "Caution – use of controls or adjustments or performance of procedures other than those specified herein may result in hazardous radiation exposure"

CONTROLS

OUTPUT LED (S5N-PL/ML...B01/C01)

The yellow LED ON indicates that the N.O. (normally open) output status is closed.

POWER ON LED

The green LED indicates that the sensor is operating.

TRIMMER (S5N-PL/ML...B01/C01)

The trimmer can be used to adjust sensitivity; the operating distance increases turning the trimmer clockwise.

WARNING: The trimmer rotation is limited to 270° by a mechanical stop.

Do not apply excessive torque when adjusting (max 40 Nmm).

INSTALLATION

S5N-PL: The sensor can be fixed by means of the M18x1 threaded body through a \varnothing 18 mm hole, using the specific washer and the two CH.24 nuts enclosed (1.5 Nm maximum tightening torque). Alternatively, the sensor can be mounted through the two housing's holes using two screws (M3x22 or longer) and washer. Amongst the various possible solutions, we suggest to choose the combination that offers the best visibility of the signalling LEDs and the easiest access to the trimmer. 22 mm nuts, h=8 mm, (2 Nm maximum tightening torque) are available to guarantee an improved torque.

S5N-ML: The sensor can be fixed by means of the M18x1 threaded body through a \varnothing 18 mm hole, using the two CH.24 nuts enclosed (22 Nm maximum tightening torque).

For both plastic version and metallic version are available various orientable fixing brackets to ease the sensor positioning (please refer to the accessories listed in the general catalogue).

The operating distance is measured from the front surface of the sensor lens.

In case of lateral translation, the object must move as indicated in the figure.



CONNECTIONS

The connections are compliant to the EN 60947-5-2 standard.

M12 CONNECTOR

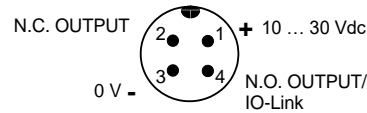

DIMENSIONS

S5N-PL VERSIONS

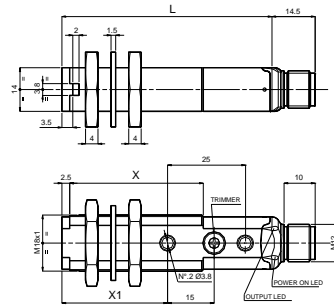

	MODELS	
	B/C/F version	G version
L	67	57
X	43	42
X1	34	24

S5N-ML VERSIONS

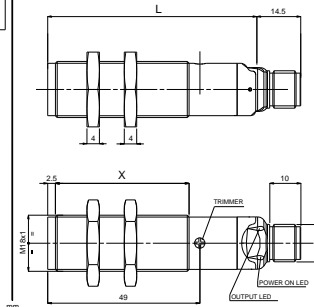

	MODELS	
	B/C/F version	G version
L	67	57
X	43	38

TECHNICAL DATA

	S5N-PL PLASTIC VERSIONS	S5N-ML METALLIC VERSIONS
Power supply:	10 ... 30 Vdc (limit values)	
Ripple:	2 Vpp max.	
Current consumption (output current excluded):	35 mA max. (mod.B01/C01/F01) 30 mA max (mod.G00)	
Outputs:	N.O. and N.C.; PNP or NPN (short-circuit protection)	
Output current:	100 mA max.	
Capacitive load:	C _{max} <= 1.5 uF @24V, I _{load} = 100mA C _{max} <= 3.5 uF @24V, I _{load} = 10mA	
Output saturation voltage:	2 V max.	
Response time:	333 µs	
Switching frequency:	1.5 kHz	
Indicators:	OUTPUT LED (YELLOW) (mod.B01/C01/F01) / POWER ON LED (GREEN)	
Setting:	sensitivity trimmer (mod.B01/C01/F01)	
Operating mode:	LIGHT mode on N.O. output / DARK mode on N.C. output (mod.C01) DARK mode on N.O. output / LIGHT mode on N.C. output (mod.B01/F01)	
Operating temperature:	-10 ... 50 °C	
Storage temperature:	-25 ... 70 °C	
Insulating strength:	500 Vac 1 min., between electronics and housing	
Insulating resistance:	>20 MΩ 500 Vdc, between electronics and housing	
Operating distance (typical values):	B01: 0.1...16 m on R2 C01: 0...35 cm	
Emission type:	RED LASER: Class 1 IEC 60825-1 (2014) (mod.B01/C01/G00) Class 1 CDRH 21 CFR PART 1040.10 (mod.B01/C01/G00) Max. power ≤ 1 mW; Pulse = 5 µS; λ = 645...660nm; Frequency ≤ 25 kHz	
Ambient light rejection:	according to EN 60947-5-2	
Vibrations:	0.5 mm amplitude, 10 ... 55 Hz frequency, for every axis (EN60068-2-6)	
Shock resistance:	11 ms (30 G) 6 shock for every axis (EN60068-2-27)	
Housing material:	PBT	Nickel plated brass
Lens material:	PMMA	
Mechanical protection:	IP67 Metal versions type 1 enclosure	
Connections:	M12 - 4 pole connector	
Weight:	25 g. max. connector vers.	60 g. max. connector vers.

SETTING

Setting of S5N-PL/ML...B01

Position the sensor and reflector on opposite sides. Turn the sensitivity trimmer to the maximum position. Moving the sensor both vertically and horizontally, determine the power ON and OFF points of the OUTPUT LED and then mount the sensor in the middle of the points defined. If necessary reduce sensitivity in order to detect very small targets.

In order to improve alignment, repeat the procedure detailed above whilst progressively reducing the sensitivity.

Setting of S5N-PL/ML...C01

Turn the sensitivity trimmer to minimum: the OUTPUT LED is OFF.

Position the target to detect in front of the sensor.

Turn the sensitivity trimmer clockwise until the OUTPUT LED turns ON (Target detected state, pos.A).

Remove the target, the OUTPUT LED turns OFF.

Turn the sensitivity trimmer clockwise until the OUTPUT LED turns ON (Background detected state, pos.B).

The trimmer reaches maximum if the background is not detected.

Turn the trimmer to the intermediate position C, between the two positions A and B.



Datasensing S.r.l.

Strada S. Caterina 235 - 41122 Modena - Italy
Tel: +39 059 420411 - Fax: +39 059 253973 - www.datasensing.com

The warranty period for this product is 36 months. See General Terms and Conditions of Sales for further details.



For information about the disposal of Waste Electrical and Electronic Equipment (WEEE), please refer to the website at www.datasensing.com.

© 2018 - 2022 Datasensing S.r.l. • ALL RIGHTS RESERVED. • Without limiting the rights under copyright, no part of this documentation may be reproduced, stored in or introduced into a retrieval system, or transmitted in any form or by any means, or for any purpose, without the express written permission of Datasensing S.r.l. • Datasensing and the Datasensing logo are trademarks of Datasensing S.r.l. • Datalogic and the Datalogic logo are registered trademarks of Datalogic S.p.A. in many countries, including the U.S and the E.U.

S5N-PL/ML SERIE BEDIENUNGSANLEITUNG



Informationen zur IO-Link-Kommunikation finden Sie auf der letzten Seite dieses Handbuchs.



IEC 60825-1 "Vorsicht – Die Verwendung von Steuerungen oder die Anpassung oder Durchführung von Verfahren, die nicht in dieser Anleitung beschrieben sind, können zu einer gefährlichen Strahlenbelastung führen"

ANZEIGE-, UND BEDIENELEMENTE

AUSGANGS LED (S5N-PL/ML...B01/C01)

Die gelbe LED signalisiert, Ausgang N.O. (normalerweise geöffnet) ist geschlossen.

POWER ON LED

Die grüne LED signalisiert Betriebsbereitschaft.

TRIMMER (S5N-PL/ML...B01/C01)

Mit dem Trimmer kann die Empfindlichkeit eingestellt werden. Drehung im Uhrzeigersinn vergrößert die Reich- oder Tastweite.

Achtung: Der Drehwinkel des Trimmers ist auf 270° mechanisch begrenzt.

Wenden Sie keine extreme Kraft bei der Einstellung an (max. 40 Nmm).

INSTALLATION

S5N-PL: Der Sensor ermöglicht aufgrund seiner M18x1 Gewindebauform und unter Verwendung von zwei mitgelieferten Muttern (SW 24 mm/max. Drehmoment 1.5 Nm) sowie einer speziellen Druckscheibe, die Montage durch eine einfache Bohrung mit Ø 18 mm.

Zudem kann der Sensor auch mit zwei Schrauben (M3x22 oder länger) und Unterlegscheiben mittels Gehäusebohrungen befestigt werden. Wählen Sie stets eine Befestigungsmöglichkeit, mit der beste Einsicht und einfachster Zugriff von Anzeige- und Bedienelemente gewährleistet ist.

Muttern mit SW 22 mm/h=8 mm (max. Drehm. 2 Nm) garantieren verbesserte Sensorbefestigung.

S5N-ML: Der Sensor ermöglicht aufgrund seiner M18x1 Gewindebauform und unter Verwendung von zwei mitgelieferten Muttern (SW 24 mm/max. Drehmoment 22 Nm) die Montage durch eine einfache Bohrung mit Ø 18 mm.

Eine Vielzahl an Haltewinkeln garantiert für beide Versionen (Metall und Kunststoff) verbesserte und einfache Sensorbefestigung (s. auch Kapitel Zubehör in Katalog od. Datenblatt).

Die Erfassung eines Objektes wird verbessert, wenn die Entfernung von Objekt zur Optikfläche vergrößert oder verringert wird und die Bewegungsrichtung des Objektes gem. nebenstehender Abbildung beachtet wird.



ANSCHLUSS

Der Anschluß entspricht der EN 60957-5-2

M12 STECKER

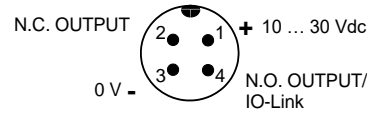

ABMESSUNGEN

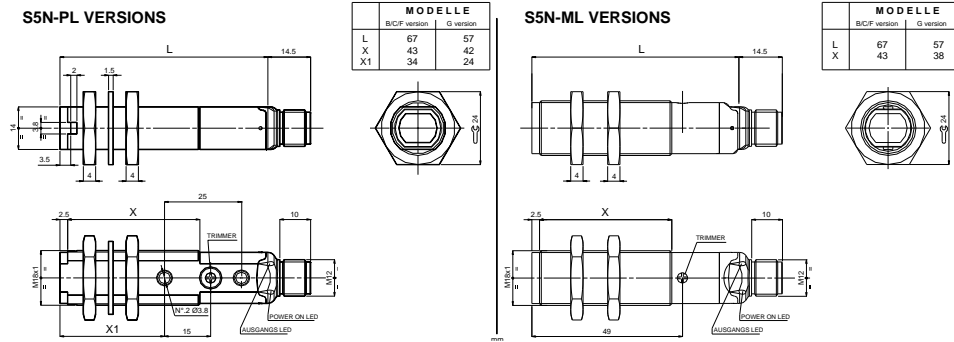

TECHNISCHE DATEN

	S5N-PL KUNSTSTOFF VERSION	S5N-ML METALL VERSION
Betriebsspannung:	10 ... 30 Vdc (begrenzte Werte)	
Welligkeit:	2 Vpp max.	
Stromaufnahme (ohne Last):	35 mA max. (bei Mod. B01/C01/F01) 30 mA max. (bei Mod. G00)	
Ausgänge:	N.O. und N.C.; PNP oder NPN (kurzschlußfest)	
Ausgangsstrom:	100 mA max.	
Kapazitive Last:	C _{max} ≤ 1.5 uF @24V, I _{load} = 100mA C _{max} ≤ 3.5 uF @24V, I _{load} = 10mA	
Sättigungsspannung:	2 V max.	
Anspruchzeit:	333 µs	
Schaltfrequenz:	1.5 kHz	
Anzeigen:	OUTPUT LED (gelb) (Mod. B01/C01/F01) /POWER ON LED (grün)	
Empfindlichkeitseinstellung:	Trimmer bei Mod. B01/C01/F01	
Betriebsart:	Hell bei Ausgang N.O. / Dunkel bei Ausgang N.C. (Mod. C01) Dunkel bei Ausgang N.O. / Hell bei Ausgang N.C. (Mod. B01/F01)	
Betriebstemperatur:	-10 ... 50°C	
Lagertemperatur:	-25 ... 70°C	
Dielektrische Durchschlagsfestigkeit:	500 Vca 1 min. zwischen elektronischen Teilen und Gehäuse	
Isolationswiderstand:	>20 MΩ 500 Vdc, zwischen elektronischen Teilen und Gehäuse	
Reich-/Tastweiten (typische Werte):	B01: 0.1 ... 16 m gegen R2 C01: 0 ... 35 cm	
Sender, Wellenlänge:	Rotlicht Laser: Schutzklasse 1 nach IEC 60825-1 (2014) (bei Mod. B01/C01/G00) Schutzklasse 1 CDRH 21 CFR PART 1040.10 (mod.B01/C01/G00) Max. power ≤ 1 mW; Pulse = 5 µS; λ = 645...660 nm; Frequency ≤ 25 kHz	
Umgebungshelligkeit:	gem. EN 60947-5-2	
Vibration:	Amplitude 0.5 mm, Schaltfrequenz 10 ... 55Hz, für allen Achsen (EN60068-2-6)	
Schockbeständigkeit:	11 ms (30G) 6 Schocks für allen Achsen (EN60068-2-27)	
Gehäuse:	PBT	Messing vernickelt
Linien:	PMMA	
Schutzart:	IP67 Metall-Versionen Gehäuseart 1	
Anschluß:	M12 Stecker 4-polig	
Gewicht:	25 g Stecker Vers.	60 g Stecker Vers.

EINSTELLUNG

Ausrichtung S5N-PL/ML...B01

Montieren Sie den Sensor und den Reflektor gegenüberliegend.

Drehen Sie den Trimmer auf Maximum.

Ermitteln Sie durch vertikale und horizontale Bewegung die Einschaltpunkte (gelbe LED geht an) und fixieren dann den Sensor zentrisch zwischen den Einschaltpunkten.

Falls notwendig, Empfindlichkeit mittels Trimmer reduzieren um sehr kleine Objekte zu detektieren. Die Ausrichtung wird verbessert wenn diese Prozedur mehrmals wiederholt wird, während die Empfindlichkeit jeweils zurückgenommen wird.

Ausrichtung S5N-PL/ML...C01

Montieren Sie den Sensor und drehen Sie den Trimmer auf Minimum: Die gelbe LED ist AUS.

Plazieren Sie das Objekt vor dem Sensor. Drehen Sie den Trimmer im Uhrzeigersinn bis die gelbe LED leuchtet (Objekt detektiert; Stellung A).



Entfernen Sie das Objekt, die gelbe LED erlischt. Drehen Sie den Trimmer im Uhrzeigersinn bis die gelbe LED leuchtet (Hintergrund detektiert; Stellung B).

Erreichen Sie nun den Trimmer, genau mittig zwischen Stellung A und B, in Stellung C.

Datasensing S.r.l.

Strada S. Caterina 235 - 41122 Modena - Italy
Tel: +39 059 420411 - Fax: +39 059 253973 - www.datasensing.com

Die Gewährleistungsfrist für dieses Produkt beträgt 36 Monate. Für weitere Informationen siehe allgemeine Verkaufsbedingungen unter www.datasensing.com.



Informationen zur Entsorgung von Elektro- und Elektronik- Altgeräten (WEEE) erhalten Sie auf der Webseite www.datasensing.com.

© 2018 - 2022 Datasensing S.r.l. • ALLE RECHTE VORBEHALTEN. • Ohne die im Urheberrecht festgelegten Rechte einzuschränken, darf kein Teil dieses Dokuments ohne die ausdrückliche schriftliche Erlaubnis von Datasensing S.r.l., in einem Datenabragesystem gespeichert oder eingeführt oder in irgendeiner Form, mittels irgendwelcher Methode oder für irgendwelchen Zweck übermittelt werden. • Datasensing und das Logo von Datasensing sind Handelsmarken von Datasensing S.r.l. • Datalogic und das Logo von Datalogic sind eingetragene Handelsmarken von Datalogic S.p.A. in vielen Ländern, einschließlich den USA und der EU.

SERIE S5N-PL/ML MANUEL D'INSTRUCTIONS



Les informations sur la communication IO-Link sont disponibles à la dernière page de ce manuel.

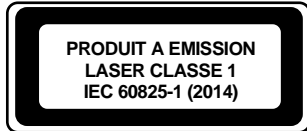

IEC 60825-1 "Attention - L'utilisation de commandes ou réglages ou l'exécution de procédures autres que celles spécifiées dans ce manuel, peuvent être cause d'une exposition à un rayonnement dangereux."

CONTRÔLES

LED DE SORTIE (S5N-PL/ML...B01/C01)

La LED jaune allumée indique l'état de la sortie NO fermé.

LED POWER ON

La LED verte indique que le détecteur est en fonctionnement.

POTENTIOMETRE (S5N-PL/ML...B01/C01)

Le potentiomètre peut être utilisé pour ajuster la sensibilité; la distance de détection augmente en tournant dans le sens horaire.

ATTENTION: La rotation du potentiomètre est limitée à 270° par un arrêt mécanique. Ne pas appliquer une torsion excessive lors de l'ajustement. (max 40 Nmm).

INSTALLATION

S5N-PL: L'installation du capteur peut être effectuée grâce au filetage M18x1 du corps sur un trou débouchant (∅ 18mm) à l'aide de la rondelle appropriée et des deux écrous CH.24 (couple maximum de serrage 1.5Nm) fournis ou bien, grâce aux deux trous traversants du corps, au moyen de deux vis (M3x22 ou d'une longueur supérieure) dotées des rondelles de serrage. Parmi les différentes combinaisons possibles choisir celle qui offre la meilleure visibilité des LED de signalisation et l'accès au trimmer. Des écrous CH.22, h=8mm, (couple maxi de serrage 2Nm) sont disponibles en vue d'une plus grande force de serrage.

S5N-ML: L'installation du capteur peut être effectuée grâce au filetage M18x1 du corps sur un trou débouchant (∅ 18mm) à l'aide des deux écrous CH.24 (couple maximum de serrage 22Nm) fournis.

Des écrous ainsi que de nombreuses équerres orientables, en vue de faciliter le positionnement du capteur (voir accessoires au catalogue) sont disponibles soit pour le boîtier plastique que pour le boîtier métallique.

La distance opérationnelle est mesurée à partir de la surface frontale de la lentille du capteur.

En cas de translation latérale, pour avoir la meilleure résolution, l'objet doit se déplacer suivant l'indication reportée sur la figure.



CONNEXIONS

Les connexions sont configurées en conformité avec la norme EN 60947-5-2.

CONNECTEUR M12

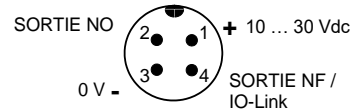

DIMENSIONS

VERSION S5N-PL

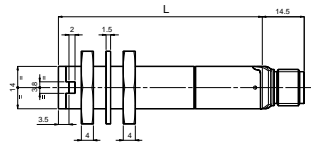

	MODELLE	
	version B/CF	version G
L	67	57
X	43	42
X1	34	24

VERSION S5N-ML

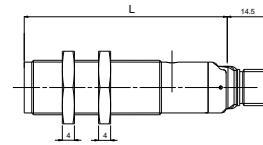

	MODELLE	
	version B/CF	version G
L	67	57
X	43	38

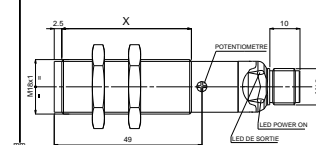
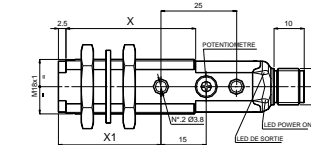

DONNEES TECHNIQUES

	VERSION PLASTIQUE S5N-PL	VERSION METALLIQUE S5N-ML
Alimentation:	10 ... 30 Vcc valeurs limites	
Ondulation:	2 Vpp max.	
Consommation (hors courant de sortie):	35 mA max. (B01/C01/F01) 30 mA max (G00)	
Sortie:	NO et NF: PNP ou NPN (protection contre le court-circuit)	
Courant de sortie:	100 mA max.	
Charge capacitive:	C _{max} ≤ 1.5 uF @24V, I _{load} = 100mA C _{max} ≤ 3.5 uF @24V, I _{load} = 10mA	
Tension de saturation en sortie:	2 V max.	
Temps de réponse:	333 µs	
Fréquence de commutation:	1.5 kHz	
Indicateurs:	LED DE SORTIE (JAUNE) (mod.B01/C01/F01) / LED POWER ON (VERTE)	
Ajustement:	Potentiomètre de réglage (mod.B01/C01/F01)	
Mode operationnel:	mode CLAIR sur NO / mode SOMBRE sur NF (mod.C01) mode SOMBRE sur NO / mode CLAIR sur NF (mod.B01/F01)	
Température de fonctionnement:	-10 ... 50 °C	
Température de stockage:	-25 ... 70 °C	
Rigidité diélectrique:	500 Vca / 1 min. entre composants électroniques et boîtier	
Résistance d'isolement:	>20 MΩ / 500 Vcc, entre composants électroniques et boîtier	
Distance de détection (valeurs typiques):	B01: 0.1 ... 16 m sur R2 C01: 0 ... 35 cm	
Type d'émission:	LASER Rouge: Classe 1 IEC 60825-1 (2014) (mod.B01/C01/G00) Classe 1 CDRH 21 CFR PART 1040.10 (mod.B01/C01/G00) Puissance max. ≤ 1 mW; Durée de l'impulsion = 5 µs; λ = 645...660 nm; fréquence ≤ 25 kHz	
Réjection à la lumière ambiante:	EN 60947-5-2	
Vibrations:	0.5 mm amplitude, 10 ... 55Hz fréquence, pour chaque axes (EN60068-2-6)	
Résistance aux chocs:	11 ms (30 G) 6 chocs pour chaque axes (EN60068-2-27)	
Boîtier:	PBT	PBT
Lentilles:	PMMA	
Classe de protection:	IP67 Boîtier type 1, versions en métal	
Connexions:	connecteur M12 4-pôles	
Poids:	25 g. max vers connecteur.	60 g. max vers connecteur.

REGLAGES

Réglage S5N-PL/ML...B01

Placer le capteur et le réflecteur sur des côtés opposés.

Régler le trimmer de la sensibilité au maximum.

En déplaçant le capteur dans la direction verticale et horizontale, déterminer les points d'allumage et d'extinction de la LED de sortie, fixer le capteur au centre entre les points relevés.

Le cas échéant, réduire la sensibilité au moyen du trimmer approprié, pour repérer des objets très petits.

En vue d'améliorer l'alignement, refaire la procédure décrite ci-dessus, en réduisant progressivement la sensibilité.

Réglage S5N-PL/ML...C01

Régler le trimmer de la sensibilité au minimum:

LED de sortie est éteinte.

Mettre en face du capteur l'objet qui doit être détecté. Tourner le trimmer de la sensibilité dans le sens des aiguilles d'une montre jusqu'à l'allumage de la LED de sortie (*Condition d'objet détecté, pos. A*). Retirer l'objet, la LED jaune s'éteint.

Tourner le trimmer dans le sens des aiguilles d'une montre jusqu'à allumer la LED de sortie (*Condition de fond détecté, pos. B*).

Le trimmer atteint le maximum, si le fond n'est pas détecté.

Régler le trimmer dans la position intermédiaire, pos. C, entre les deux positions: pos. A et pos. B.



Datasensing S.r.l.

Strada S. Caterina 235 - 41122 Modena - Italy
Tel: +39 059 420411 - Fax: +39 059 253973 - www.datasensing.com

La période de garantie pour ce produit est de 36 mois. Voir les Conditions Générales de Vente sur www.datasensing.com pour plus de détails.



Pour toute information relative à l'élimination des déchets électroniques (WEEE), veuillez consulter le site internet www.datasensing.com.

© 2018-2022 Datasensing S.r.l. • TOUS DROITS RÉSERVÉS. • Aucune partie de cette documentation ne peut être reproduite, stockée ou introduite dans un système de recherche, ni transmise sous quelque forme ou par quelque moyen que ce soit, ni à quelque fin que ce soit, sans l'autorisation écrite expresse de Datasensing S.r.l. • Datasensing et le logo Datasensing sont des marques de commerce de Datasensing S.r.l. • Datalogic et le logo Datalogic sont des marques de commerce de Datalogic S.p.A. déposées dans de nombreux pays, y compris les États Unis et l'Union Européenne.

SERIE S5N-PL/ML MANUALE ISTRUZIONI



Le informazioni relative alla comunicazione IO-Link sono disponibili nell'ultima pagina del presente manuale.



IEC 60825-1 "Attenzione - L'uso di comandi, l'adozione di regolazioni o l'espletamento di procedure difformi da quelle specificate nel presente manuale possono provocare l'esposizione a radiazioni pericolose"

CONTROLLI

LED DI USCITA (S5N-PL/ML...B01/C01)

Il LED giallo acceso indica lo stato dell'uscita N.A. (normalmente aperto) chiuso.

LED POWER ON

Il LED verde indica che il sensore è in funzione.

TRIMMER (S5N-PL/ML...B01/C01)

Il trimmer permette di regolare la sensibilità; la distanza operativa aumenta ruotando il trimmer in senso orario.

ATTENZIONE: La rotazione massima del trimmer è limitata a 270°. Non forzare oltre le posizioni massima e minima, in particolare non esercitare una coppia maggiore di 40 Nmm.

INSTALLAZIONE

S5N-PL: L'installazione del sensore può essere effettuata grazie alla filettatura M18x1 del corpo su foro passante (∅ 18 mm) utilizzando l'apposita rondella ed i due dadi CH.24 (coppia max. di serraggio 1.5 Nm) in dotazione oppure, grazie ai due fori passanti del corpo, tramite due viti (M3x22 o di maggiore lunghezza) con rondelle di serraggio. Tra le varie combinazioni possibili scegliere quella che offre la maggiore visibilità dei LED di segnalazione e l'accesso al trimmer.

Sono disponibili dadi CH.22, h=8 mm, (coppia max. di serraggio 2 Nm) per una maggiore forza di serraggio.

S5N-ML: L'installazione del sensore può essere effettuata grazie alla filettatura M18x1 del corpo su foro passante (∅ 18 mm) utilizzando i due dadi CH.24 (coppia max. di serraggio 22 Nm) in dotazione.

Sia per la versione plastica che metallica sono disponibili numerose staffe orientabili per facilitare il posizionamento del sensore (vedi accessori a catalogo).

La distanza operativa è misurata a partire dalla superficie frontale della lente del sensore.

In caso di traslazione laterale, per ottenere la massima risoluzione l'oggetto si deve muovere come indicato in figura.



CONNESSIONI

Le connessioni sono configurate in conformità con la norma EN 60947-5-2.

CONNETTORE M12

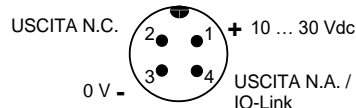

DIMENSIONI D'INGOMBRO

VERSIONI S50-PL

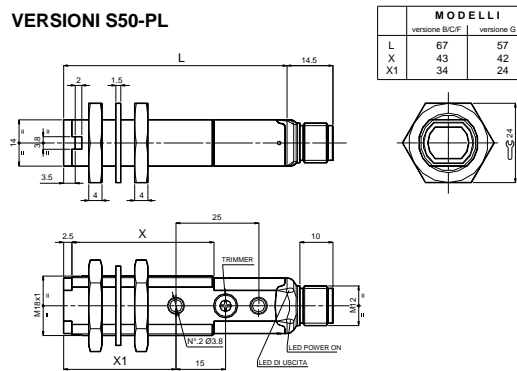

VERSIONI S50-ML

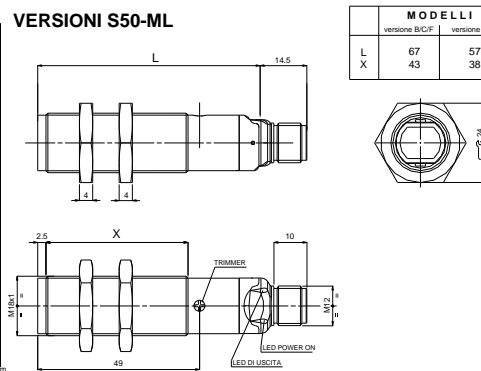

DATI TECNICI

	VERSIONI PLASTICHE S5N-PL	VERSIONI METALLICHE S5N-ML
Tensione di alimentazione:	10 ... 30 Vcc valori limite	
Tensione di ripple:	2 Vpp max.	
Absorbimento (esclusa corrente di uscita):	35 mA max. (mod.B01/C01/F01) 30 mA max. (mod.G00)	
Uscite:	N.A. e N.C.; PNP o NPN (protezione contro il cortocircuito)	
Corrente di uscita:	100 mA max.	
Carico capacitivo:	C _{max} ≤ 1.5 uF @24V, I _{load} = 100mA C _{max} ≤ 3.5 uF @24V, I _{load} = 10mA	
Tensione di saturazione dell'uscita:	2 V max.	
Tempo di risposta:	333 us	
Frequenza di commutazione:	1.5 kHz	
Indicatori:	LED DI USCITA (GIALLO) (mod.B01/C01/F01) / LED POWER ON (VERDE)	
Impostazione:	trimmer di sensibilità (mod.B01/C01/F01)	
Modo operativo:	modo LUCE su uscita N.A. / modo BUIO su uscita N.C. (mod.C01) modo BUIO su uscita N.A. / modo LUCE su uscita N.C. (mod.B01/F01)	
Temperatura di funzionamento:	-10 ... 50 °C	
Temperatura di immagazzinamento:	-25 ... 70 °C	
Rigidità dielettrica:	500 Vca 1 min tra parti elettroniche e contenitore	
Resistenza d'isolamento	>20 MΩ 500 Vcc tra parti elettroniche e contenitore	
Distanza operativa (valori tipici):	B01: 0.1...16 m su R2 C01: 0...35 cm	
Tipo di emissione:	LASER ROSSO: Classe 1 IEC 60825-1 (2014) (mod.B01/C01/G00) Classe 1 CDRH 21 CFR PART 1040.10 (mod.B01/C01/G00) Potenza max. ≤ 1 mW; Impulso = 5uS; λ = 645...660 nm; Frequenza ≤ 25kHz	
Reiezione alla luce ambiente:	come prescritto da EN 60947-5-2	
Vibrazioni:	ampiezza 0.5 mm, frequenza 10 ... 55 Hz, per ogni asse (EN60068-2-6)	
Resistenza agli urti:	11 ms (30 G) 6 shock per ogni asse (EN60068-2-27)	
Materiale contenitore:	PBT	Ottone nichelato
Materiale lenti:	PMMA	
Protezione meccanica:	IP67 Contenitore tipo 1, versioni metalliche	
Collegamenti:	connettore M12 a 4 poli	
Peso:	25 g. max. vers. conn.	60 g. max. vers. conn.

REGOLAZIONI

Regolazione S5N-PL/ML...B01

Posizionare il sensore ed il riflettore su lati opposti.

Regolare il trimmer della sensibilità al massimo.

Muovendo il sensore in direzione verticale e orizzontale, determinare i punti di accensione e spegnimento del LED di uscita, fissare il sensore al centro tra i punti rilevati.

Se necessario, ridurre la sensibilità per individuare oggetti molto piccoli.

Per migliorare l'allineamento, ripetere la procedura sopra descritta riducendo progressivamente la sensibilità.

Regolazione S5N-PL/ML...C01

Regolare il trimmer della sensibilità al minimo: il LED di uscita è spento.

Porre di fronte al sensore l'oggetto che deve essere rilevato.

Ruotare il trimmer della sensibilità in senso orario finché il LED di uscita si accende (Condizione di oggetto rilevato, pos.A).

Togliere l'oggetto, il LED di uscita si spegne.

Ruotare il trimmer in senso orario fino all'accensione del LED di uscita (Condizione di sfondo rilevato, pos.B).

Il trimmer raggiunge il massimo se lo sfondo non viene rilevato.

Regolare il trimmer in posizione intermedia, pos.C, tra le due posizioni pos.A e pos.B.



Datasensing S.r.l.

Strada S. Caterina 235 - 41122 Modena - Italy
Tel: +39 059 420411 - Fax: +39 059 253973 - www.datasensing.com

Il periodo di garanzia per questo prodotto è di 36 mesi. Per maggiori dettagli vedere Condizioni Generali di Vendita su www.datasensing.com.



Per informazioni sullo smaltimento delle apparecchiature elettriche ed elettroniche (WEEE) consultare il sito Web www.datasensing.com.

© 2018 - 2022 Datasensing S.r.l. • TUTTI I DIRITTI RISERVATI. • Senza con ciò limitare i diritti coperti dal copyright, nessuna parte della presente documentazione può essere riprodotta, memorizzata o introdotta in un sistema di recupero o trasmessa in qualsiasi forma o con qualsiasi mezzo, o per qualsiasi scopo, senza l'espresso consenso scritto di Datasensing S.r.l. • Datasensing e il logo Datasensing sono marchi di Datasensing S.r.l. • Datalogic e il logo Datalogic sono marchi registrati di Datalogic S.p.A. depositati in diversi paesi, tra cui U.S.A. e UE.

S5N-PL/ML 系列

说明手册



有关 IO-Link 通信的信息，请参阅本手册最后一页。



IEC 60825-1 “小心 - 进行非本文指定的控制使用或调整及流程执行可能会导致辐射暴露的危险”

控制

输出 LED (S5N-PL/ML...B01/C01)

黄色 LED 亮起表示 N.O. (常开) 输出状态为已关闭。

开机 LED

绿色 LED 表示传感器正在运行。

微调器 (S5N-PL/ML...B01/C01)

微调器可用于调节灵敏度；顺时针转动微调器时，工作距离增加。

警告：微调器的旋转通过机械限位器限制在 270°。

调整时请勿施加过大的扭矩 (最大 40 Nmm)。

安装

S5N-PL: 使用专用垫圈和两个封闭式 CH.24 螺母 (最大拧紧扭矩 1.5 Nm)，可以通过 M18x1 螺纹径 \varnothing 18 mm 孔将传感器固定。或者，可以使用两个螺钉 (M3x22 或更长) 和垫圈通过外壳的两个孔安装传感器。

在各种可能的解决方案中，我们建议选择能够提供信号 LED 的最佳可见性和最方便使用微调器的组合。

22 mm 螺母、h=8 mm (2 Nm 最大拧紧扭矩) 可用于保证更高的扭矩。

S5N-ML: 使用两个封闭式 CH.24 螺母 (最大拧紧扭矩 22 Nm)，可以通过 M18x1 螺纹径 \varnothing 18 mm 孔将传感器固定。

对于塑料版本和金属版本，各种可定向固定支架可用于简化传感器定位 (请参阅总目录中列出的附件)。

从传感器镜头的前表面开始测量工作距离。在横向平移的情况下，物体必须按如图所示方式移动。



连接

连接符合 EN 60947-5-2 标准。

M12 连接器

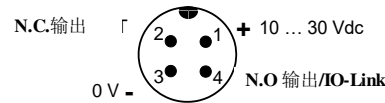

尺寸

S5N-PL 版本

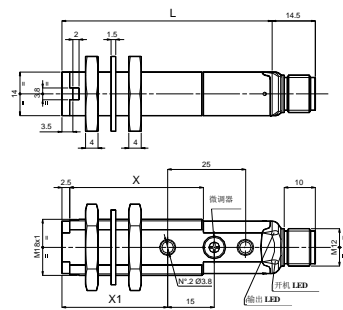

	BCP 版	型号	G 版
L	67	57	
X	43	42	
X1	34	24	

S5N-ML 版本

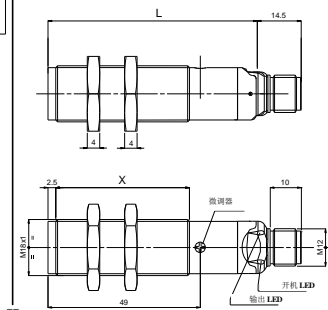

	BCP 版	型号	G 版
L	67	57	
X	43	38	

技术数据

	S5N-PL 塑料版本	S5N-ML 金属版本
电源:	10 ... 30 Vdc (极限值)	
纹波:	最大 2 Vpp	
电流消耗 (不包括输出电流):	最大 35 mA (B01/C01/F01 型号) 最大 30 mA (G00 型号)	
输出:	N.O. 和 N.C.: PNP 或 NPN (短路保护)	
输出电流:	最大 100 mA.	
电容性负载:	C _{max} ≤ 1.5 uF @24V, I _{load} = 100mA C _{max} ≤ 3.5 uF @24V, I _{load} = 10mA	
输出饱和电压:	最大 2 V.	
响应时间:	333 μs	
开关频率:	1,5 kHz	
指示灯:	输出 LED (黄色) (B01/C01/F01 型号)/开机 LED (绿色)	
设置:	灵敏度微调器 (B01/C01/F01 型号)	
工作模式:	N.O. 输出时为 LIGHT 模式/N.C. 输出时为 DARK 模式 (C01 型号) N.O. 输出时为 DARK 模式/N.C. 输出时为 LIGHT 模式 (B01/F01 型号)	
工作温度:	-10 ... 50 °C	
储存温度:	-25 ... 70 °C	
绝缘强度:	500 Vac 1 min., 电子设备与外壳之间	
绝缘电阻:	>20 MΩ 500 Vdc, 电子设备与外壳之间	
工作距离 (典型值):	B01: R2 上 0.1...16 m C01: 0...35 cm	
发射类型:	红色激光: 1 类 IEC 60825-1 (2014) (B01/C01/G00 型号) 1 类 CDRH 21 CFR PART 1040.10 (B01/C01/G00 型号) 最大功率 ≤ 1 mW; 脉冲 = 5 μs; λ = 645...660nm; 频率 ≤ 25 kHz	
环境光抑制:	符合 EN 60947-5-2	
振动:	每个轴 0.5 mm 振幅, 10 ... 55 Hz 频率 (EN60068-2-6)	
抗冲击性:	每个轴 11 ms (30 G) 6 次冲击 (EN60068-2-27)	
外壳材料:	PBT	镀镍黄铜
镜头材料:	PMMA	
机械保护:	IP67 金属版本 1 型外壳	
连接:	M12 - 4 针连接器	
重量:	连接器版本最大 25 g.	连接器版本最大 60 g.

设置

S5N-PL/ML...B01 设置

将传感器和反射镜相对放置。

将灵敏度微调器转动到最大位置。

垂直和水平移动传感器，确定输出 LED 的开启和关闭点，然后将传感器安装在定义点的中间。

如有必要，降低灵敏度以检测非常小的目标。

为改善对准，请重复上文详细介绍的步骤，同时逐渐降低灵敏度。

S5N-PL/ML...C01 设置

将灵敏度微调器转动到最小：输出 LED 熄灭。

将要检测的目标放置在传感器前面。

顺时针转动灵敏度微调器，直到输出 LED 亮起

(目标检测状态，位置 A)。

移除目标，输出 LED 熄灭。

顺时针转动灵敏度微调器，直到输出 LED 亮起 (背景检测状态，位置 B)。

如果未检测到背景，则微调器达到最大值。

将微调器转动到位置 A 和 B 之间的中间位置 C。



Datasensing S.r.l.

Strada S. Caterina 235 - 41122 Modena - Italy

电话: +39 059 420411 - 传真: +39 059 253973 -

www.datasensing.com

本产品的保修期为 36 个月。有关详细信息，请参阅“一般销售条款和条件”。



有关处置报废电子电气设备 (WEEE) 的信息，请参阅网站 www.datasensing.com。

© 2018 - 2022 Datasensing S.r.l. ◆ 保留所有权利。◆ 在不限制版权所有权利，或未经 Datasensing S.r.l. 的书面许可的情况下，不得对此文档的任何一部分进行复制、存储或将其引入检索系统，不得以任何形式、通过任何方法对此文档进行传播，不得将此文档用于任何目的。◆ Datasensing 和 Datasensing 徽标是 Datasensing S.r.l. 的商标。◆ Datalogic 和 Datalogic 标志是 Datalogic S.p.A. 在美国和欧盟等诸多国家或地区的注册商标。



S5N

IO-Link® parameters

PHYSICAL LAYER

Description	
IO-Link Revision	1.1
SIO Modus	YES
Min Cycle Time	5 ms (LED models) / 8 ms (Laser models)
Transmission Rate	38,4 kbit/s (COM2)
Process Data Length	PDInput: 24 Bit PDOOutput: 1 Bit
M-Sequence Capability	PREOPERATE: TYPE_0 OPERATE: TYPE_2_V ISDU: supported

FEATURES

Description	
Block Parameter	YES
Data Storage	YES
Supported Access Locks	Parameter (write) access Data Storage
Profile Characteristic	Device Profile: Smart Sensor Function Class: Device Identification Function Class: Binary Data Channel Function Class: Process Data Variable Function Class: Device Diagnosis Function Class: Teach Channel Function Class: Teach-in Single Value Function Class: Transducer Disable

SERVICE DATA

The following ISDUs will not be saved via Data Storage: Device Access Locks (index 0xC), Teach-in Channel (index 0x3A), Adjustment Mode (index 0x66)

System Parameters							
Index (dec)	Parameter Object Name	Lenght	Subindex (offset)	Value/Range	Description	Data Type	Access*
0x000C (12)	Device Access Locks	2 octets		Bit 1: Data Storage (0 = unlocked, 1 = locked)	Standardized Device locking functions: Bit 0: Parameter (write) access (not used) Bit 1: Data Storage Bit 2: Local parameterization (Not used) Bit 3: Local user interface (Not used) Bit 4-15: Reserved	RecordT	R/W
0x000D (13)	Profile Characteristics	2 octets 2 octets 2 octets 2 octets 2 octets 2 octets 2 octets		0x0001 0x8000 0x8001 0x8002 0x8003 0x8004 0x8007 0x800C	Smart Sensor Profile Device Identification Binary Data Channel (BDC) Process Data Variable (PDV) Device Diagnosis Teach Channel Teach-in single value Transducer Disable	ArrayT of UIntegerT16	RO
0x000E (14)	PDInput Descriptor	3 octets 3 octets 3 octets 3 octets		0x01.0x01.0x00 0x01.0x01.0x01 0x01.0x01.0x02 0x01.0x01.0x03 0x02.0x10.0x08	SSC1 (OUT0) SSC2 (OUT1) TEACH STATUS FLAG STABILITY (C01) / ALARM (B01) PDV1 (NORMALIZED DISTANCE (M03) / LIGHT RECEIVED (W03, B01, C01, T01))	ArrayT of OctetStringT3	RO
0x000F (15)	PDOOutput Descriptor	3 octets		0x01.0x01.0x00	TRANSDUCER DISABLE	ArrayT of OctetStringT3	RO

*RO = read only, WO = write only, R/W = read/write

Identification Parameters								
Index (dec)	Parameter Object Name	Length	Subindex (offset)	Value/Range	Description	Data Type	Access*	Remark
0x0010 (16)	Vendor Name	9 octets		DATALOGIC	Informative	StringT	RO	
0x0011 (17)	Vendor Text	19 octets		Empower your vision		StringT	RO	
0x0012 (18)	Product Name	15 octets		See "Device variant collection" on page 5	Detailed product name	StringT	RO	
0x0013 (19)	Product ID	5 octets		See "Device variant collection" on page 5	Product identification	StringT	RO	
0x0014 (20)	Product Text	21 octets		See "Device variant collection" on page 5		StringT	RO	
0x0015 (21)	Serial Number	9 octets			Unique serial number	StringT	RO	
0x0016 (22)	Hardware Revision	5 octets		RevAE		StringT	RO	
0x0017 (23)	Firmware Revision	5 octets		5.0.0		StringT	RO	
0x0018 (24)	Application Specific Tag	32 octets		*** (default)	Tag application defined by user	StringT	R/W	Saved in non-volatile memory
0x0019 (25)	Function Tag	32 octets		*** (default)	Additional tag for device function identification	StringT	R/W	Saved in non-volatile memory
0x001A (26)	Location Tag	32 octets		*** (default)	Additional tag for device function identification	StringT	R/W	Saved in non-volatile memory

Observation / Diagnostic Parameters								
Index (dec)	Parameter Object Name	Length	Subindex (offset)	Value/Range	Description	Data Type	Access*	Remark
0x0028 (40)	Process Data Input	3 octets			Read last valid Process Data Input from PDin channel	Device specific	RO	
0x0029 (41)	Process Data Output	1 octet			Read last valid Process Data Output from PDout channel	Device specific	RO	
0x0052 (82)	Device Temperature	2 octets 2 octets 2 octets 2 octets 2 octets	1(64) 2(48) 3(32) 4(16) 5(0)		Device temperature actual Device min. temperature since powerup Device max. temperature since powerup Device min. temperature during lifetime Device max. temperature during lifetime	IntegerT IntegerT IntegerT IntegerT IntegerT	RO RO RO RO RO	
0x0053 (83)	Device Temperature Threshold	2 octets 2 octets	1(16) 2(0)		Device min. temperature threshold (B01, C01, T01) Device max. temperature threshold (B01, C01, T01)	IntegerT IntegerT	R/W	Saved in non-volatile memory every hour. Events are generated if the device temperature exceeds the thresholds.
0x0057 (87)	Operating Hours	4 octets 4 octets 4 octets	1(64) 2(32) 3(0)	0...(2^32)-1	Operating Hours: device operating hours. Not resettable by user. Operating Hours Maintenance: device operating hours, reset on system command "Confirm Maintenance". Operating Hours Power Up: Time in hours since power up.	UIntegerT UIntegerT UIntegerT	RO RO RO	
0x0024 (36)	Device Status	1 octet		0x00 → Device is operating properly 0x01 → Maintenance Required 0x02 → Out of specification 0x03 → Functional Check 0x04 → Failure	Contains current status of the device	UIntegerT	RO	
0x0025 (37)	Detailed Device Status	3 octets			Information about currently pending Events. Implemented as dynamic list.	UIntegerT	RO	
0x00BE (190)	Excess gain	2 octets		100...900	Excess gain (EG) = 0 if signal is under threshold (B01 LED, C01, T01)	UIntegerT	RO	

*RO = read only, WO = write only, R/W = read/write

Teach-in Parameters								
Index (dec)	Parameter Object Name	Lenght	Subindex (offset)	Value/Range	Description	Data Type	Access*	Remark
0x003A (58)	TI Select	1 octet		0x00 = SSC1 (default, C/Q pin and DO pin)	Selection for Teach-in channel (volatile)	UIntegerT	R/W	C/Q and DO outputs are antivalent. Teach SSC1 equals to teach SSC2
0x003B (59)	TI Result	1 octet	1(0) 2(4) 3(5)	Teach-in State Flag SP1 TP1 Flag SP2 TP1	See IO-Link Smart Sensor Profile	UIntegerT4 BooleanT BooleanT	RO	
0x003C (60)	SSC1 Param	2 octets 2 octets	1(16) 2(0)	0-4095 Not used	Normalized distance (M03) / Switching threshold (W03) / Trimmer value (sensitivity adjustment) (Trimmer models)	UIntegerT	R/W	Saved in non-volatile memory
0x003D (61)	SSC1 Config	1 octet	1(24)	0x00: High Active (default C01, M03, W03) 0x01: Low Active (default B01, T01)	C/Q pin configuration	UIntegerT	R/W	Saved in non-volatile memory
		1 octet	2(16)	0x01: Single Point (default)		UIntegerT		
		2 octets	3(0)	Not used (M03) 0 ..10 Hysteresis (W03) 0 - 1 Hysteresis (Trimmer models)		UIntegerT		
0x003E (62)	SSC2 Param	2 octets 2 octets	1(16) 2(0)	0-4095 Non used	Normalized distance	UIntegerT	R/W	Saved in non-volatile memory
0x003F (63)	SSC2 Config	1 octet	1(24)	0x00: High Active (default B01, T01) 0x01: Low Active (default C01, M03, W03)	DO pin configuration	UIntegerT	R/W	Saved in non-volatile memory
		1 octet	2(16)	0x01: Single Point (default)		UIntegerT		
		2 octets	3(0)	Not used (M03) 0 ..10 Hysteresis (W03) 0 - 1 Hysteresis (Trimmer models)		UIntegerT		
0x0066 (102)	Adjustment mode	1 octet		0x00 = manual (default) 0x01 = IO-Link	Status of trimmer regulation (manual/IO-Link) (B01, C01, T01)	BooleanT	R/W	

*RO = read only, WO = write only, R/W = read/write

Device Specific Parameters								
Index (dec)	Parameter Object Name	Length	Subindex (offset)	Value/Range	Description	Data Type	Access*	Remark
0x0048 (72)	Delay Settings	1 octet	1(64)	0 = no delay (default) 0x2 = Delay ON 0x3 = One Shot 0x4 = Delay OFF	Select Delay mode (ON / OFF/ ONE SHOT)	UIntegerT	R/W	Saved in non-volatile memory
		4 octets	2(32)	0...(2 ³²)-1	Delay ON value = Delay [ms] *1000 / 141 (M03) Delay [ms] *1000 / 45 (W03) Delay [ms] *1000 / 157 (T01/C01/B01 LED emission) Delay [ms] *1000 / 67 (C01 Laser) Delay [ms] *1000 / 70 (B01 Laser)	UIntegerT	R/W	
		4 octets	3(0)	0...(2 ³²)-1	Delay OFF value = Delay [ms] *1000 / 141 (M03) Delay [ms] *1000 / 45 (W03) Delay [ms] *1000 / 157 (T01/C01/B01 LED emission) Delay [ms] *1000 / 67 (C01 Laser) Delay [ms] *1000 / 70 (B01 Laser)	UIntegerT	R/W	
0x00B4 (180)	Output type	1 octet	1(8)	0x01 = PNP (default) 0x03 = Push Pull ⁽¹⁾	Output type of C/Q pin when in SIO mode	UIntegerT	R/W	Saved in non-volatile memory
		1 octet	2(0)	0x01 = PNP (default) 0x02 = NPN 0x03 = Push Pull	Output type of DO pin	UIntegerT	R/W	

⁽¹⁾ The No Output configured in Push Pull mode with an NPN load does not reactivate after a short circuit condition. Remove the short circuit condition and cycle power to the sensor.

Standard Command						
Index (dec)	Command Name	Length	Value (dec)	Description	Access*	
0x0002 (2)	SP1 Single Value Teach	1 octet	0x41 (65)	Acquisition EASY (refer to User's Manual) (M03, W03) / Teach Set Point (B01, C01, T01)	WO	
0x0002 (2)	SP1 Teach TP1	1 octet	0x43 (67)	Acquisition FINE: Mark Detection (refer to User's Manual) (W03)	WO	
0x0002 (2)	SP1 Teach TP2	1 octet	0x44 (68)	Acquisition FINE: Background Detection (refer to User's Manual) (W03)	WO	
0x0002 (2)	Teach FINE	1 octet	0x4B (75)	Acquisition FINE (refer to User's Manual) (M03)	WO	
0x0002 (2)	Teach CANCEL	1 octet	0x4F (79)	Exit from teach FAIL status (M03) / Exit from Fine detection (W03)	WO	
0x0002 (2)	Restore Factory Settings	1 octet	0x82 (130)	Restore factory settings (Device Access Locks, Application Specific Tag, Function Tag, Location Tag, SSC1 Param, SSC2 Param, Delay Settings, Output Type, Adjust Mode)	WO	
0x0002 (2)	Confirm Maintenance	1 octet	0xA5 (165)	Reset Maintenance parameters (Operating Hours Maintenance, Minimum device temperature since powerup, Maximum device temperature since powerup, Device Status, Detailed Device Status)	WO	
0x0002 (2)	Disable IO-Link adjustment	1 octet	0xAB (171)	Disable teach via IO-Link, re-enable trimmer adjustment (B01, C01, T01)	WO	
0x0002 (2)	Start / Stop Ping	1 octet	0xAF (175)	Feature to identify the sensor by yellow led blinking	WO	

Events					
Event code (dec)	Event name	Event mode	Event type	Device status	Remarks
0x4220 (16928)	Temperature underrun	Appears / Disappears	Warning	Out of specification	only B01, C01, T01
0x4210 (16912)	Temperature overrun	Appears / Disappears	Warning	Out of specification	
0x5100 (20736)	General power supply fault	Appears / Disappears	Error	Failure	
0x7710 (30480)	Short circuit - Check installation	Appears / Disappears	Error	Failure	
0x8C40 (35904)	Maintenance required - Lens cleaning	Appears / Disappears	Notification	Maintenance required	only B01
0x8CA0 (36000)	Laser fault	Appears / Disappears	Error	Failure	only Laser models

PROCESS DATA

Process Data Output							
Byte 0							
7	6	5	4	3	2	1	0
Not used							TRANSDUCER DISABLE
Process Data Input							
Byte 2							
23	22	21	20	19	18	17	16
PDV1 (Normalized distance (M03) ⁽²⁾ / LIGHT RECEIVED (W03, B01, C01, T01) (MSB))							
Byte 1							
15	14	13	12	11	10	9	8
PDV1 (Normalized distance (M03) ⁽²⁾ / LIGHT RECEIVED (W03, B01, C01, T01) (LSB))							
Byte 0							
7	6	5	4	3	2	1	0
Not used				Not used (W03, M03, T01), Stability (C01) Alarm (B01)	TEACH-IN	SSC2 (DO pin)	SSC1 (C/Q pin)

⁽²⁾ Process data will not be valid in case of out-of-range values.

DEVICE VARIANT COLLECTION

Product name	Product ID	Product text	Device ID
S5N-PA-5-C01-OZ	02210	Diffuse proximity	2
S5N-MA-5-C01-OZ	22200	Diffuse proximity	
S5N-PA-5-M03-OZ	02230	Background suppression	3
S5N-MA-5-M03-OZ	22170	Background suppression	
S5N-PA-5-W03-OZ	02240	Mark reader	4
S5N-PL-5-C01-OZ	02260	Diffuse proximity laser	5
S5N-ML-5-C01-OZ	22190	Diffuse proximity laser	
S5N-PL-5-B01-OZ	02250	Reflex polarized laser	6
S5N-ML-5-B01-OZ	22180	Reflex polarized laser	
S5N-PA-5-B01-OZ	02200	Reflex polarized	7
S5N-MA-5-B01-OZ	22160	Reflex polarized	
S5N-PA-5-T01-OZ	02220	Reflex transparent	8

EN	CE Compliance
<p>CE marking states the compliance of the product with essential requirements listed in the applicable European directive. Since the directives and applicable standards are subject to continuous updates, and since the manufacturer promptly adopts these updates, therefore the EU declaration of conformity is a living document. The EU declaration of conformity is available for competent authorities and customers through the manufacturer's commercial reference contacts. Since April 20th, 2016 the main European directives applicable to the products require inclusion of an adequate analysis and assessment of the risk(s). This evaluation was carried out in relation to the applicable points of the standards listed in the Declaration of Conformity. These products are mainly designed for integration purposes into more complex systems. For this reason, it is under the responsibility of the system integrator to do a new risk assessment regarding the final installation.</p>	
<p>Warning This is a Class A product. In a domestic environment this product may cause radio interference in which case the user may be required to take adequate measures.</p>	

IT	Conformità CE
<p>La marcatura CE dichiara la conformità del prodotto con i requisiti essenziali elencati nella direttiva europea applicabile. Essendo le direttive e le normative applicabili soggette a continui aggiornamenti, e dato che il costruttore adotta immediatamente tali aggiornamenti, la dichiarazione di conformità CE è un documento vivo. La dichiarazione di conformità CE è disponibile per le autorità competenti e i clienti tramite i contatti commerciali di riferimento al costruttore. Dal 20 aprile 2016, le principali direttive europee applicabili ai prodotti richiedono l'inserimento di un'adeguata analisi e valutazione dell/i rischi(o). Tale valutazione è stata realizzata in relazione ai punti applicabili delle normative elencate nella Dichiarazione di Conformità. Questi prodotti sono progettati principalmente per essere integrati in sistemi più complessi. Per questo motivo, l'integratore di sistemi è responsabile della realizzazione di una nuova valutazione dei rischi riguardante l'installazione finale.</p>	
<p>Attenzione Si tratta di un prodotto di Classe A. In un ambiente domestico questo prodotto può generare interferenze radio. In tal caso è necessario prendere le dovute misure.</p>	

DE	EG-Konformität
<p>Die CE-Kennzeichnung bestätigt die Konformität des Produkts mit den wesentlichen Anforderungen der geltenden europäischen Richtlinien. Da die Richtlinien und anwendbaren Normen laufend aktualisiert werden und der Hersteller diese Aktualisierungen umgehend übernimmt, ist die EU-Konformitätserklärung ein fortschreitendes Dokument. Die EU-Konformitätserklärung ist für zuständige Behörden und Kunden über die Handelskontakte von dem Hersteller erhältlich. Seit dem 20. April 2016 erfordern die wichtigsten für diese Produkte anwendbaren Europäischen Richtlinien die Integration einer angemessenen Analyse und der Bewertung der Risiken. Diese Bewertung wird in Bezug auf die anwendbaren Punkte der in der Konformitätserklärung aufgelisteten Normen durchgeführt. Diese Produkte werden in erster Linie für die Integration in komplexere Systeme ausgelegt. Aus diesem Grund liegt es in der Verantwortung des Systemintegrators, eine neue Risikobewertung der Endinstallation vorzunehmen.</p>	
<p>Warnung Dies ist ein Produkt nach Klasse A. In einem häuslichen Umfeld kann dieses Produkt Funkstörungen auslösen, gegebenenfalls hat der Benutzer dann angebrachte Maßnahmen zu ergreifen.</p>	

FR	Conformité CE
<p>La marque CE indique la conformité du produit aux exigences essentielles énoncées dans la directive européenne applicable. Les directives et les normes applicables sont sujettes à des mises à jour de manière continue et le constructeur adopte rapidement ces mises à jour ; la déclaration de conformité UE est par conséquent un document vivant. La déclaration de conformité UE est disponible aux autorités compétentes et aux clients à travers les interlocuteurs commerciaux de référence des constructeurs. Depuis le 20 Avril 2016 les principales directives européennes applicables aux produits exigent l'inclusion d'une analyse et d'une évaluation adéquates du/des risque/s. Cette évaluation a été réalisée en relation avec les points applicables des normes indiquées dans la Déclaration de Conformité. Ces produits sont principalement conçus à des fins d'intégration dans des systèmes plus complexes. Pour cette raison, il est de la responsabilité de l'intégrateur de système d'effectuer une nouvelle évaluation des risques concernant l'installation finale.</p>	
<p>Avertissement Ceci est un produit de Classe A. Dans un environnement domestique, ce produit peut provoquer des interférences radio auquel cas l'utilisateur peut se trouver dans l'obligation de prendre des mesures adéquates.</p>	

ES	Conformidad CE
<p>La marca CE establece la conformidad del producto con los requisitos fundamentales enumerados en la directiva europea aplicable. Debido a que las directivas y normativas aplicables están sujetas a actualización continua, como el constructor adopta estas actualizaciones de inmediato, la declaración de conformidad UE es un documento activo. La declaración de conformidad UE está disponible para las autoridades competentes y para los clientes a través de los contactos comerciales de referencia del constructor. Desde el 20 de abril de 2016, las principales directivas europeas aplicables a los productos exigen la inclusión de un idóneo análisis y evaluación de riesgos. Esta evaluación ha sido efectuada sobre los puntos aplicables de la normativa indicada en la Declaración de Conformidad. Estos productos han sido diseñados a fin de ser integrados en sistemas más complejos. Por ello, es responsabilidad del integrador del sistema efectuar una nueva evaluación de riesgos relativa a la instalación final.</p>	
<p>Advertencia Este es un producto de Clase A. En un entorno doméstico, este producto puede causar interferencias radioeléctricas; en este caso, el usuario debería tomar medidas adecuadas.</p>	

NL	EU-conformiteitsverklaring
<p>Met de CE-markering wordt verklaard dat het product voldoet aan de essentiële eisen zoals vermeld in de toepasselijke Europese richtlijnen. Daar de richtlijnen en de toepasselijke normen onderhevig zijn aan voortdurende aanpassingen, en de fabrikant deze aanpassingen direct toepast, is de EU-conformiteitsverklaring een levend document. De EU-conformiteitsverklaring is beschikbaar voor bevoegde autoriteiten en klanten via contactgegevens voor commerciële referentie. Sinds 20 april 2016 vereisen de belangrijkste Europese richtlijnen de inclusie van een adequate risicoanalyse- en beoordeling. Deze beoordeling werd uitgevoerd met betrekking tot de toepasselijke punten van de normen zoals vermeld in de Conformiteitsverklaring. Deze producten zijn voornamelijk ontworpen voor integratie in complexere systemen. Om deze reden is het de verantwoordelijkheid van de systeemintegrator om een nieuwe risicobeoordeling uit te voeren met betrekking tot de definitieve installatie.</p>	
<p>Waarschuwing Dit is een Klasse A product. In een woonomgeving kan dit product radiostoring veroorzaken, in welk geval de gebruiker mogelijk verplicht is om adequate maatregelen te treffen.</p>	

S5N-Mx SERIES INSTRUCTION MANUAL



Information on IO-Link communication is available on the last page of this manual.

CONTROLS

OUTPUT LED (S5N-Mx...B01/C01)

The yellow LED ON indicates that the N.O. (normally open) output status is closed.

STABILITY LED (S5N-Mx...B01/C01)

The green LED ON indicates that the received signal has a reserve greater than 30% compared to the output switching value.

TRIMMER (S5N-Mx...B01/C01)

The trimmer can be used to adjust sensitivity; the operating distance increases turning the trimmer clockwise.

WARNING: The trimmer rotation is limited to 270° by a mechanical stop. Do not apply excessive torque when adjusting (max 40 Nmm).

INSTALLATION

The sensor can be fixed by means of the M18x1 threaded body through a \varnothing 18 mm hole, using the two CH.24 nuts enclosed (22 Nm maximum tightening torque).

Wide range of accessories available: various orientable fixing brackets ease the sensor positioning (please refer to the accessories listed in the general catalogue).

The operating distance is measured from the front surface of the sensor lens.

C_models: To improve the detection, the object has to be moved closer or further away from the front surface of the sensor lens.



In case of lateral translation, the object must move as indicated in the figure.

CONNECTIONS

The connections are compliant to the EN 60947-5-2 standard.

M12 CONNECTOR

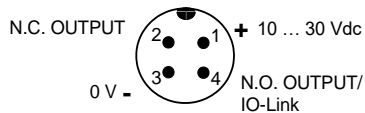

DIMENSIONS

AXIAL VERSION

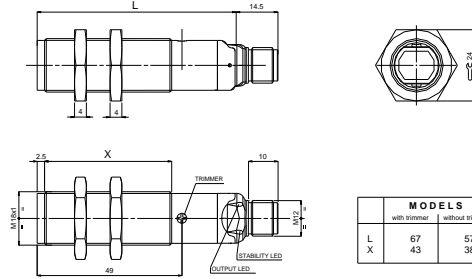

MODELS	
	with trimmer
L	67
X	43
E	57
	38

RADIAL VERSION

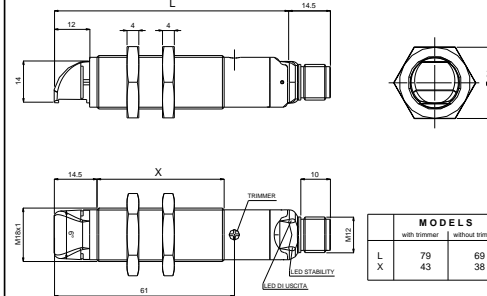

MODELS	
	with trimmer
L	79
X	43
E	69
	38

FIBRE OPTIC VERSION

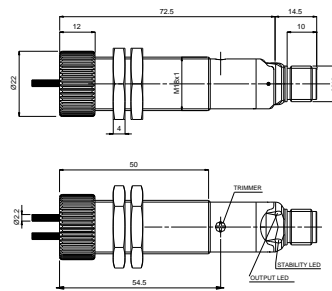

TECHNICAL DATA

	S5N-MA AXIAL VERSION	S5N-MR RADIAL VERSION
Power supply:	10 ... 30 Vdc (limit values)	
Ripple:	2 Vpp max.	
Current consumption (output current excluded):	35 mA max.	
Outputs:	N.O. and N.C.; PNP or NPN (short-circuit protection)	
Output current:	100 mA max.	
Capacitive load:	C _{max} ≤ 1.5 uF @24V, I _{load} = 100mA C _{max} ≤ 3.5 uF @24V, I _{load} = 10mA	
Output saturation voltage:	2 V max.	
Response time:	0.5 ms (2 ms mod.F01/G00)	
Switching frequency:	1 kHz (250 Hz mod.F01/G00)	
Indicators:	OUTPUT LED (YELLOW) excluding mod.G00 STABILITY LED (GREEN) (mod.B01/C01/C21/E01/F01) POWER ON LED (GREEN) (mod.G00)	
Setting:	sensitivity trimmer (mod.B01/C01/C21/E01/F01/T01)	
Operating temperature:	-25 ... 55 °C	
Storage temperature:	-25 ... 70 °C	
Dielectric strength:	500 Vac / 1 min. between electronic parts and housing	
Insulation resistance:	>20 MΩ / 500 Vdc, between electronic parts and housing	
Operating distance (typical values):	B01: 0.1...3.5 m on R2 C01: 0...60 cm	B01: 0.1...2 m on R2 C01: 0...35 cm
Emission type:	red (630 nm) (mod. E01) / red (660 nm) (mod.B01/T01) infrared (880 nm) (mod. C01/C21/G00)	
Ambient light rejection:	according to EN 60947-5-2	
Vibrations:	0.5 mm amplitude, 10 ... 55 Hz frequency, for every axis (EN60068-2-6)	
Shock resistance:	11 ms (30 G) 6 shock for every axis (EN60068-2-27)	
Housing material:	Nickel-plated brass	
Lens material:	PMMA	
Mechanical protection:	IP67 Type 1 enclosure	
Connections:	M12 - 4 pole connector	
Weight:	60 g. max. connector vers.	
AtEx 2014/34/EU	I I 3G EX nA II T6 ; I I 3D EX ID A2 IP67 T85°C	

SETTING

Setting of S5N-Mx...B01

Position the sensor and reflector on opposite sides. Turn the sensitivity trimmer to the maximum position. Moving the sensor both vertically and horizontally, determine the power on and off points of the yellow LED (OUT) and then mount the sensor in the middle of the points defined. Optimum operation is obtained when the green LED (mod.B01) is ON and the yellow LED is OFF.

B01 models: If necessary reduce sensitivity in order to detect very small targets. In order to improve alignment, repeat the procedure detailed above whilst progressively reducing the sensitivity.



Setting of S5N-Mx...C01

Turn the sensitivity trimmer to minimum: the green LED is ON, the yellow LED is OFF. Position the target to detect in front of the sensor or of the fibre terminals. Turn the sensitivity trimmer clockwise until the yellow LED turns ON (Target detected state, pos.A). Remove the target, the yellow LED turns OFF. Turn the sensitivity trimmer clockwise until the yellow LED turns ON (Background detected state, pos.B).

The trimmer reaches maximum if the background is not detected. Turn the trimmer to the intermediate position C, between the two positions A and B. The green LED must be ON.

Datasensing S.r.l.

Strada S. Caterina 235 - 41122 Modena - Italy
Tel: +39 059 420411 - Fax: +39 059 253973 - www.datasensing.com

The warranty period for this product is 36 months. See General Terms and Conditions of Sales for further details.



For information about the disposal of Waste Electrical and Electronic Equipment (WEEE), please refer to the website at www.datasensing.com.

© 2007 - 2022 Datasensing S.r.l. • ALL RIGHTS RESERVED. • Without limiting the rights under copyright, no part of this documentation may be reproduced, stored in or introduced into a retrieval system, or transmitted in any form or by any means, or for any purpose, without the express written permission of Datasensing S.r.l. • Datasensing and the Datasensing logo are trademarks of Datasensing S.r.l. • Datalogic and the Datalogic logo are registered trademarks of Datalogic S.p.a. in many countries, including the U.S and the E.U.

S5N-Mx SERIE BEDIENUNGSANLEITUNG



Informationen zur IO-Link-Kommunikation finden Sie auf der letzten Seite dieses Handbuchs.

ANZEIGE-, UND BEDIENELEMENTE

AUSGANGS LED (S5N-Mx...B01/C01)

Die gelbe LED signalisiert, Ausgang N.O. (normalerweise geöffnet) ist geschlossen.

STABILITÄTS LED (S5N-Mx...B01/C01)

Die grüne LED signalisiert den sicheren Betriebszustand, wobei das empfangene Signal im Vergleich zur Schaltschwelle größer als 30% ist.

TRIMMER (S5N-Mx...B01/C01)

Mit dem Trimmer kann die Empfindlichkeit eingestellt werden. Drehung im Uhrzeigersinn vergrößert die Reich- oder Tastweite.

Achtung: Der Drehwinkel des Trimmers ist auf 270° mechanisch begrenzt. Wenden Sie keine extreme Kraft bei der Einstellung an (max. 40Nm).

INSTALLATION

Der Sensor ermöglicht aufgrund seiner M18x1 Gewindebauform und unter Verwendung von zwei mitgelieferten Muttern (SW 24mm/max. Drehmoment 22 Nm) die Montage durch eine einfache Bohrung mit Ø 18 mm.

Sensorzubehör: eine Vielzahl an Haltewinkeln garantiert verbesserte und einfache Sensorbefestigung (s. auch Kapitel Zubehör in Katalog od. Datenblatt).

Angaben bzgl. Reich-/Tastweite beziehen sich auf Optiktfläche.

C. Modelle: Die Erfassung eines Objektes wird verbessert, wenn die Entfernung von Objekt zur Optiktfläche vergrößert oder verringert wird und die Bewegungsrichtung des Objektes gem. nebenstehender Abbildung beachtet wird.



ANSCHLUSS

Der Anschluß entspricht der EN 60957-5-2

M12-STECKERVERSION

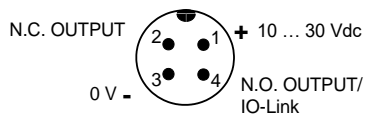

ABMESSUNGEN

AXIALE VERSION

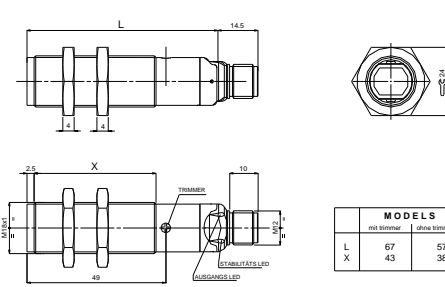

RADIALE VERSION

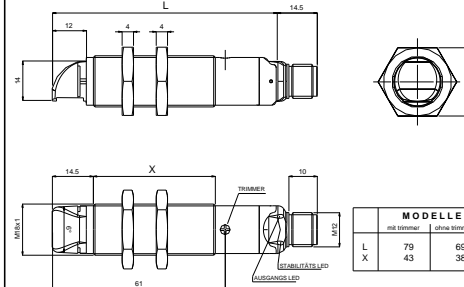

LICHTLEITER VERSION

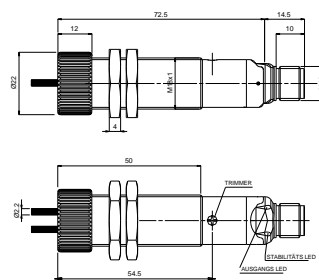

MODELLE	
	ohne Trimmer
L	67
X	43

MODELLE	
	ohne Trimmer
L	79
X	43

TECHNISCHE DATEN

	S5N-MA AXIALE VERSION	S5N-MR RADIALE VERSION
Betriebsspannung:	10 ... 30 Vdc (begrenzte Werte)	
Welligkeit:	2 Vpp max.	
Stromaufnahme (ohne Last):	35 mA max.	
Ausgänge:	N.O. und N.C.; PNP oder NPN (kurzschlußfest)	
Ausgangsstrom:	100 mA max.	
Kapazitive Last:	C _{max} ≤ 1.5 µF @24V, I _{load} = 100mA C _{max} ≤ 3.5 µF @24V, I _{load} = 10mA	
Sättigungsspannung:	2 V max.	
Ansprechzeit:	0.5 ms (2 ms bei Mod. F01/G00)	
Schaltfrequenz:	1 kHz (250 Hz bei Mod. F01/G00)	
Anzeigen:	OUTPUT LED (gelb) ausgenommen Mod. G00 STABILITÄT LED (grün) bei Mod. B01/C01/C21/E01/F01 POWER ON LED (grün) bei Mod. G00	
Empfindlichkeitseinstellung:	Trimmer bei Mod. B01/C01/C21/E01/F01/T01	
Betriebstemperatur:	-25 ... 55°C	
Lagertemperatur:	-25 ... 70°C	
Dielektrische Durchschlagsfestigkeit:	500 Vca 1 min. zwischen elektronischen Teilen und Gehäuse	
Isolationswiderstand:	>20 MΩ 500 Vdc, zwischen elektronischen Teilen und Gehäuse	
Reich-/Tastweiten (typische Werte):	B01: 0.1 ... 3.5 m gegen R2 C01: 0 ... 60 cm	B01: 0.1 ... 2 m gegen R2 C01: 0 ... 35 cm
Sender, Wellenlänge:	ROT, 630 nm (bei Mod. E01) / ROT, 660 nm (bei Mod. B01/T01) INFRAROT, 880 nm (bei Mod. A00/C21/G00)	
Umgebungshelligkeit:	gem. EN 60947-5-2	
Vibration:	Amplitude 0.5 mm, Schaltfrequenz 10 ... 55Hz, für allen Achsen (EN60068-2-6)	
Schockbeständigkeit:	11 ms (30 G) 6 Schocks für allen Achsen (EN60068-2-27)	
Gehäuse:	Messing vernickelt	
Linse:	PMMA	
Schutzart:	IP67 Gehäuseart 1	
Anschluß:	M12 Stecker 4-polig	
Gewicht:	60 g Stecker Version	
AtEx 2014/34/EU	I I 3G EX nA II T6 ; I I 3D EX tD A22 IP67 T85°C	

EINSTELLUNG

Ausrichtung S5N-Mx...B01

Montieren Sie den Sensor und den Reflektor gegenüberliegend. Drehen Sie den Trimmer auf Maximum. Ermitteln Sie durch vertikale und horizontale Bewegung die Einschaltpunkte (gelbe LED geht an) und fixieren dann den Sensor zentrisch zwischen den Einschaltpunkten. Optimale Einstellung ist gegeben, wenn die grüne LED (Mod. B01) EIN und die gelbe LED AUS ist.

B01 Model: Falls notwendig, Empfindlichkeit mittels Trimmer reduzieren um sehr kleine Objekte zu detektieren. Die Ausrichtung wird verbessert wenn diese Prozedur mehrmals wiederholt wird, während die Empfindlichkeit jeweils zurückgenommen wird.



Ausrichtung S5N-Mx...C01

Montieren Sie den Sensor und drehen Sie den Trimmer auf Minimum: Die grüne LED ist ein, die gelbe LED ist aus. Platzieren Sie das Objekt vor dem Sensor. Drehen Sie den Trimmer im Uhrzeigersinn bis die gelbe LED leuchtet (Objekt detektiert; Stellung A).

Entfernen Sie das Objekt, die gelbe LED erlischt. Drehen Sie den Trimmer im Uhrzeigersinn bis die gelbe LED leuchtet (Hintergrund detektiert; Stellung B). Erreichen Sie Maximum Stellung, wird der Hintergrund nicht detektiert Drehen sie nun den Trimmer, genau mittig zwischen Stellung A und B, in Stellung C. Die grüne LED muß ständig leuchten.

Datasensing S.r.l.

Strada S. Caterina 235 - 41122 Modena - Italy
 Tel: +39 059 420411 - Fax: +39 059 253973 - www.datasensing.com

Die Gewährleistungsfrist für dieses Produkt beträgt 36 Monate. Für weitere Informationen siehe allgemeine Verkaufsbedingungen unter www.datasensing.com.



Informationen zur Entsorgung von Elektro- und Elektronik- Altgeräten (WEEE) erhalten Sie auf der Webseite www.datasensing.com.

© 2007 - 2022 Datasensing S.r.l. • ALLE RECHTE VORBEHALTEN. • Ohne die im Urheberrecht festgelegten Rechte einzuschränken, darf kein Teil dieses Dokuments ohne die ausdrückliche schriftliche Erlaubnis von Datasensing S.r.l., in einem Datenabfragesystem gespeichert oder eingeführt oder in irgendeiner Form, mittels irgendwelcher Methode oder für irgendwelchen Zweck übermittelt werden. ♦ Datasensing und das Logo von Datasensing sind Handelsmarken von Datasensing S.r.l. ♦ Datalogic und das Logo von Datalogic sind eingetragene Handelsmarken von Datalogic S.p.A. in vielen Ländern, einschließlich den USA und der EU.

SERIE S5N-Mx MANUALE ISTRUZIONI



Le informazioni relative alla comunicazione IO-Link sono disponibili nell'ultima pagina del presente manuale.

CONTROLLI

LED DI USCITA (S5N-Mx...B01/C01)

Il LED giallo acceso indica lo stato dell'uscita N.A. (normalmente aperto) chiuso.

LED STABILITY (S5N-Mx...B01/C01)

Il LED verde di stabilità acceso indica che il segnale ricevuto ha un margine di sicurezza maggiore del 30% rispetto al valore di commutazione dell'uscita.

TRIMMER (S5N-Mx...B01/C01)

Il trimmer permette di regolare la sensibilità; la distanza operativa aumenta ruotando il trimmer in senso orario.

ATTENZIONE: La rotazione massima del trimmer è limitata a 270°.

Non forzare oltre le posizioni massima e minima, in particolare non esercitare una coppia maggiore di 40 Nmm.

INSTALLAZIONE

L'installazione del sensore è effettuata grazie alla filettatura M18x1 del corpo su foro passante (\varnothing 18 mm) utilizzando i due dadi in ottone nichelato CH.24 (coppia max. di serraggio 22 Nm).

Sono disponibili numerose staffe orientabili per facilitare il posizionamento del sensore (vedi accessori a catalogo).

La distanza operativa è misurata a partire dalla superficie frontale della lente del sensore.

Modelli C: Per una migliore rilevazione, l'oggetto deve muoversi in avvicinamento od allontanamento dalla superficie delle lenti.

In caso di traslazione laterale, l'oggetto si deve muovere come indicato in figura.



CONNESSIONI

Le connessioni sono configurate in conformità con la norma EN 60947-5-2.

CONNETTORE M12

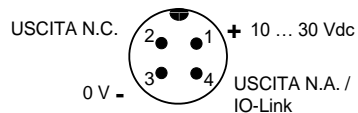

DIMENSIONI D'INGOMBRO

VERSIONE ASSIALE

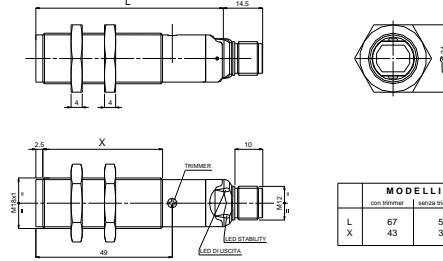

MODELLI		
	CON TRIMMER	SENZA TRIMMER
L	67	57
X	43	38

VERSIONE FIBRA OTTICA

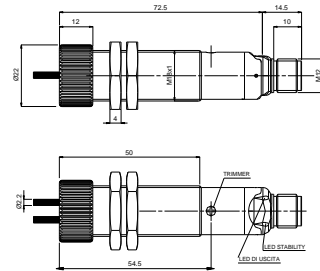

VERSIONE RADIALE

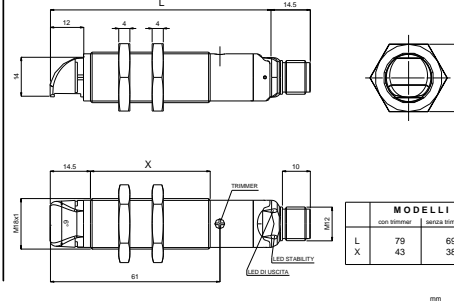

MODELLI		
	CON TRIMMER	SENZA TRIMMER
L	79	69
X	43	38

DATI TECNICI

	VERSIONE ASSIALE S5N-MA	VERSIONE RADIALE S5N-MR
Tensione di alimentazione:	10 ... 30 Vcc valori limite	
Tensione di ripple:	2 Vpp max.	
Assorbimento (esclusa corrente di uscita):	35 mA max.	
Uscite:	N.A. e N.C.; PNP o NPN (protezione contro il cortocircuito)	
Corrente di uscita:	100 mA max.	
Carico capacitivo:\	$C_{max} \leq 1.5 \mu F @ 24V, I_{load} = 100mA$ $C_{max} \leq 3.5 \mu F @ 24V, I_{load} = 10mA$	
Tensione di saturazione dell'uscita:	2 V max.	
Tempo di risposta:	0.5 ms (2 ms mod.F01/G00)	
Frequenza di commutazione:	1 kHz (250 Hz mod.F01/G00)	
Indicatori:	LED DI USCITA (GIALLO) escluso mod.G00 LED STABILITY (VERDE) (mod. B01/C01/C21/E01/F01) LED POWER ON (VERDE) (mod.G00)	
Impostazione:	trimmer di sensibilità (mod. B01/C01/C21/E01/F01/T01)	
Temperatura di funzionamento:	-25 ... 55 °C	
Temperatura di immagazzinamento:	-25 ... 70 °C	
Rigidità dielettrica:	500 Vca / 1 min. tra parti elettroniche e contenitore	
Resistenza d'isolamento	>20 M Ω / 500 Vcc, tra parti elettroniche e contenitore	
Distanza operativa (valori tipici):	B01: 0.1...3.5 m su R2 C01: 0...60 cm	B01: 0.1...2 m su R2 C01: 0...35 cm
Tipo di emissione:	rossa (630 nm) (mod. E01) / rossa (660 nm) (mod.B01/T01) / infrarossa (880 nm) (mod. C01/C21/G00)	
Reiezione alla luce ambiente:	come prescritto da EN 60947-5-2	
Vibrazioni:	ampiezza 0.5 mm, frequenza 10 ... 55 Hz, per ogni asse (EN60068-2-6)	
Resistenza agli urti:	11 ms (30 G) 6 shock per ogni asse (EN60068-2-27)	
Materiale contenitore:	ottone nichelato	
Materiale lenti:	PMMA	
Protezione meccanica:	IP67 Contenitore tipo 1	
Collegamenti:	connettore M12 a 4 poli	
Peso:	60 g. max. vers. a connettore	
ATEX 2014/34/EU	I I 3G EX nA II T6 ; I I 3D EX ID A22 IP67 T85°C	

REGOLAZIONI

Regolazione S5N-Mx...B01

Posizionare il sensore e il riflettore su lati opposti. Regolare il trimmer della sensibilità al massimo. Muovendo il sensore in direzione verticale e orizzontale, determinare i punti di accensione e spegnimento del LED giallo (OUT), fissare il sensore al centro tra i punti rilevati. Il funzionamento ottimale si ottiene quando il LED verde (mod.B01) è acceso e il LED giallo è spento.

Modelli B01: Se necessario, ridurre la sensibilità per individuare oggetti molto piccoli. Per migliorare l'allineamento, ripetere la procedura sopra descritta riducendo progressivamente la sensibilità.



Regolazione S5N-Mx...C01

Regolare il trimmer della sensibilità al minimo: il LED verde è acceso, il LED giallo è spento. Porre di fronte al sensore o ai terminali della fibra l'oggetto che deve essere rilevato. Ruotare il trimmer della sensibilità in senso orario finché il LED giallo si accende (Condizione di oggetto rilevato, pos.A). Togliere l'oggetto, il LED giallo si spegne.

Ruotare il trimmer in senso orario fino all'accensione del LED giallo (Condizione di sfondo rilevato, pos.B).

Il trimmer raggiunge il massimo se lo sfondo non viene rilevato.

Regolare il trimmer in posizione intermedia, pos.C, tra le due posizioni pos.A e pos.B. Il LED verde deve essere acceso.

Datasensing S.r.l.

Strada S. Caterina 235 - 41122 Modena - Italy
Tel: +39 059 420411 - Fax: +39 059 253973 - www.datasensing.com

Il periodo di garanzia per questo prodotto è di 36 mesi. Per maggiori dettagli vedere Condizioni Generali di Vendita su www.datasensing.com.



Per informazioni sullo smaltimento delle apparecchiature elettriche ed elettroniche (WEEE) consultare il sito Web www.datasensing.com.

© 2007 - 2022 Datasensing S.r.l. • TUTTI I DIRITTI RISERVATI. • Senza con ciò limitare i diritti coperti dal copyright, nessuna parte della presente documentazione può essere riprodotta, memorizzata o introdotta in un sistema di recupero o trasmessa in qualsiasi forma o con qualsiasi mezzo, o per qualsiasi scopo, senza l'espreso consenso scritto di Datasensing S.r.l. • Datasensing e il logo Datasensing sono marchi di Datasensing S.r.l. • Datalogic e il logo Datalogic sono marchi registrati di Datalogic S.p.A. depositati in diversi paesi, tra cui U.S.A. e UE.

S5N-Mx 系列

说明手册



有关 IO-Link 通信的信息，请参阅本手册最后一页。

控制

输出 LED (S5N-Mx...B01/C01)

黄色 LED 亮起表示 N.O. (常开) 输出状态为已关闭。

稳定性 LED (S5N-Mx...B01/C01)

绿色 LED 亮起表示接收到的信号具有比输出开关值大 30% 的保留。

微调器 (S5N-Mx...B01/C01)

微调器可用于调节灵敏度；顺时针转动微调器时，工作距离增加。

警告： 微调器的旋转通过机械限位器限制在 270°。

调整时请勿施加过大的扭矩 (最大 40 Nmm)。

安装

使用两个封闭式 CH.24 螺母 (最大拧紧扭矩 22 Nm)，可以通过 M18x1 螺纹纹径 \varnothing 18 mm 孔将传感器固定。

附件种类繁多：各种可定向固定支架可简化传感器定位 (请参阅总目录中列出的附件)。

从传感器镜头的前表面开始测量工作距离。

C 型号： 为提高检测效率，必须使物体靠近或远离传感器镜头的前表面。

在横向平移的情况下，物体必须按如图所示方式移动。



连接

连接符合 EN 60947-5-2 标准。

M12 连接器

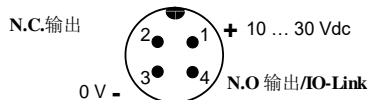

尺寸

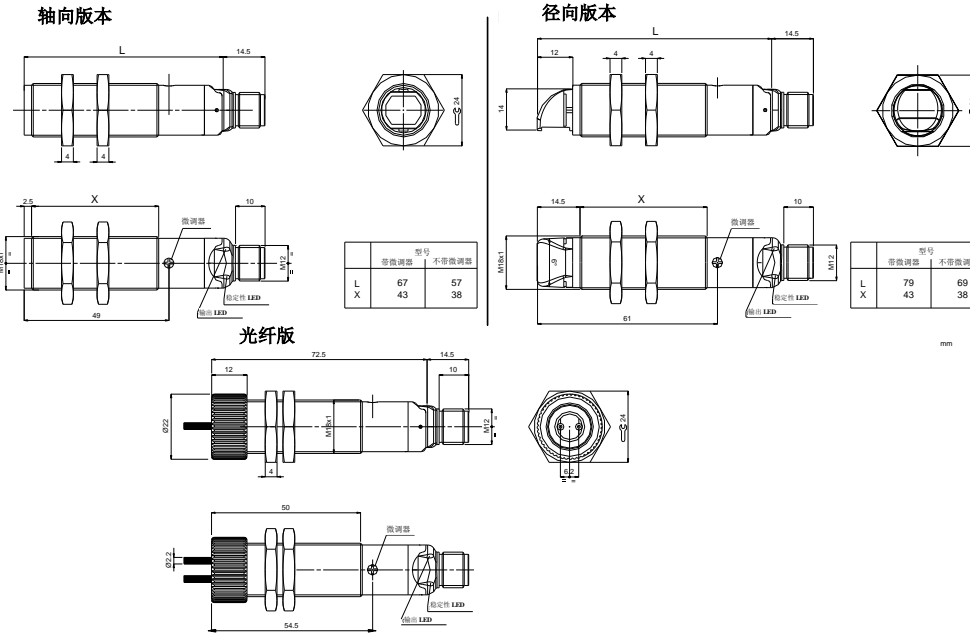

技术数据

	S5N-MA 轴向版本	S5N-MR 径向版本
电源：	10 ... 30 Vdc (极限值)	
纹波：	最大 2 Vpp	
电流消耗 (不包括输出电流)：	最大 35 mA。	
输出：	N.O. 和 N.C.：PNP 或 NPN (短路保护)	
输出电流：	最大 100 mA。	
电容性负载：	C _{max} ≤ 1.5 uF @ 24V, I _{load} = 100mA C _{max} ≤ 3.5 uF @ 24V, I _{load} = 10mA	
输出饱和电压：	最大 2 V。	
响应时间：	0.5 ms (F01/G00 型号为 2 ms)	
开关频率：	1 kHz (F01/G00 型号为 250 kHz)	
指示灯：	输出 LED (黄色)，不包括 G00 型号 稳定性 LED (绿色) (B01/C01/C21/E01/F01 型号) 开机 LED (绿色) (G00 型号)	
设置：	灵敏度微调器 (B01/C01/C21/E01/F01/T01 型号)	
工作温度：	-25 ... 55 ° C	
储存温度：	-25 ... 70 ° C	
介电强度：	500 Vac/1 min.，电子设备与外壳之间	
绝缘电阻：	>20 M Ω /500 Vdc，电子部件与外壳之间	
工作距离 (典型值)：	B01: R2 \pm 0.1...3.5 m C01: 0...60 cm	B01: R2 \pm 0.1...2 m C01: 0...35 cm
发射类型：	红色 (630 nm) (E01 型号) / 红色 (660 nm) (B01/T01 型号) 红外 (880 nm) (C01/C21/G00 型号)	
环境光抑制：	符合 EN 60947-5-2	
振动：	每个轴 0.5 mm 振幅，10 ... 55 Hz 频率 (EN60068-2-6)	
抗冲击性：	每个轴 11 ms (30 G) 6 次冲击 (EN60068-2-27)	
外壳材料：	镀镍黄铜	
镜头材料：	PMMA	
机械保护：	IP67 1 型外壳	
连接：	M12 - 4 针连接器	
重量：	连接器版本最大 60 g。	
AtEx 2014/34/EU	I I 3G EX nA II T6 ; I I 3D EX tD A22 IP67 T85 ° C	

设置

S5N-Mx...B01 设置

将传感器和反射镜相对放置。

将灵敏度微调器转动到最大位置。

垂直和水平移动传感器，确定黄色 LED (输出) 的开启和关闭点，然后将传感器安装在定义点的中间。当绿色 LED (B01 型号) 亮起并且黄色 LED 熄灭时，可获得最佳运行。

B01 型号： 如有必要，降低灵敏度以检测非常小的目标。为改善对准，请重复上文详细介绍的步骤，同时逐渐降低灵敏度。



S5N-Mx...C01 设置

将灵敏度微调器转动到最小：绿色 LED 亮起，黄色 LED 熄灭。将要检测的目标放置在传感器或光纤端子前面。顺时针转动灵敏度微调器，直到黄色 LED 亮起 (目标检测状态，位置 A)。移除目标，黄色 LED 熄灭。顺时针转动灵敏度微调器，直到黄色 LED 亮起 (背景检测状态，位置 B)。如果未检测到背景，则微调器达到最大值。

将微调器转动到位置 A 和 B 之间的中间位置 C。绿色 LED 必须亮起。

Datasensing S.r.l.

Strada S. Caterina 235 - 41122 Modena - Italy
电话：+39 059 420411 - 传真：+39 059 253973 - www.datasensing.com

本产品的保修期为 36 个月。有关详细信息，请参阅“一般销售条款和条件”。



有关处置报废电子电气设备 (WEEE) 的信息，请参阅网站 www.datasensing.com。

© 2007 - 2022 Datasensing S.r.l. ◆ 保留所有权利。◆ 在不限版权所有权的，或未经 Datasensing S.r.l. 的书面许可的情况下，不得对此文档的任何一部分进行复制、存储或将其引入检索系统，不得以任何形式、通过任何方法对此文档进行传播，不得将此文档用于任何目的。◆ Datasensing 和 Datasensing 徽标是 Datasensing S.r.l. 的商标。◆ Datalogic 和 Datalogic 标志是 Datalogic S.p.A. 在美国和欧盟等诸多国家或地区的注册商标。



S5N

IO-Link® parameters

PHYSICAL LAYER

Description	
IO-Link Revision	1.1
SIO Modus	YES
Min Cycle Time	5 ms (LED models) / 8 ms (Laser models)
Transmission Rate	38,4 kbit/s (COM2)
Process Data Length	PDInput: 24 Bit PDOOutput: 1 Bit
M-Sequence Capability	PREOPERATE: TYPE_0 OPERATE: TYPE_2_V ISDU: supported

FEATURES

Description	
Block Parameter	YES
Data Storage	YES
Supported Access Locks	Parameter (write) access Data Storage
Profile Characteristic	Device Profile: Smart Sensor Function Class: Device Identification Function Class: Binary Data Channel Function Class: Process Data Variable Function Class: Device Diagnosis Function Class: Teach Channel Function Class: Teach-in Single Value Function Class: Transducer Disable

SERVICE DATA

The following ISDUs will not be saved via Data Storage: Device Access Locks (index 0xC), Teach-in Channel (index 0x3A), Adjustment Mode (index 0x66)

System Parameters							
Index (dec)	Parameter Object Name	Lenght	Subindex (offset)	Value/Range	Description	Data Type	Access*
0x000C (12)	Device Access Locks	2 octets		Bit 1: Data Storage (0 = unlocked, 1 = locked)	Standardized Device locking functions: Bit 0: Parameter (write) access (not used) Bit 1: Data Storage Bit 2: Local parameterization (Not used) Bit 3: Local user interface (Not used) Bit 4-15: Reserved	RecordT	R/W
0x000D (13)	Profile Characteristics	2 octets 2 octets 2 octets 2 octets 2 octets 2 octets 2 octets		0x0001 0x8000 0x8001 0x8002 0x8003 0x8004 0x8007 0x800C	Smart Sensor Profile Device Identification Binary Data Channel (BDC) Process Data Variable (PDV) Device Diagnosis Teach Channel Teach-in single value Transducer Disable	ArrayT of UIntegerT16	RO
0x000E (14)	PDInput Descriptor	3 octets 3 octets 3 octets 3 octets		0x01.0x01.0x00 0x01.0x01.0x01 0x01.0x01.0x02 0x01.0x01.0x03 0x02.0x10.0x08	SSC1 (OUT0) SSC2 (OUT1) TEACH STATUS FLAG STABILITY (C01) / ALARM (B01) PDV1 (NORMALIZED DISTANCE (M03) / LIGHT RECEIVED (W03, B01, C01, T01))	ArrayT of OctetStringT3	RO
0x000F (15)	PDOOutput Descriptor	3 octets		0x01.0x01.0x00	TRANSDUCER DISABLE	ArrayT of OctetStringT3	RO

*RO = read only, WO = write only, R/W = read/write

Identification Parameters								
Index (dec)	Parameter Object Name	Length	Subindex (offset)	Value/Range	Description	Data Type	Access*	Remark
0x0010 (16)	Vendor Name	9 octets		DATALOGIC	Informative	StringT	RO	
0x0011 (17)	Vendor Text	19 octets		Empower your vision		StringT	RO	
0x0012 (18)	Product Name	15 octets		See "Device variant collection" on page 5	Detailed product name	StringT	RO	
0x0013 (19)	Product ID	5 octets		See "Device variant collection" on page 5	Product identification	StringT	RO	
0x0014 (20)	Product Text	21 octets		See "Device variant collection" on page 5		StringT	RO	
0x0015 (21)	Serial Number	9 octets			Unique serial number	StringT	RO	
0x0016 (22)	Hardware Revision	5 octets		RevAE		StringT	RO	
0x0017 (23)	Firmware Revision	5 octets		5.0.0		StringT	RO	
0x0018 (24)	Application Specific Tag	32 octets		*** (default)	Tag application defined by user	StringT	R/W	Saved in non-volatile memory
0x0019 (25)	Function Tag	32 octets		*** (default)	Additional tag for device function identification	StringT	R/W	Saved in non-volatile memory
0x001A (26)	Location Tag	32 octets		*** (default)	Additional tag for device function identification	StringT	R/W	Saved in non-volatile memory

Observation / Diagnostic Parameters								
Index (dec)	Parameter Object Name	Length	Subindex (offset)	Value/Range	Description	Data Type	Access*	Remark
0x0028 (40)	Process Data Input	3 octets			Read last valid Process Data Input from PDin channel	Device specific	RO	
0x0029 (41)	Process Data Output	1 octet			Read last valid Process Data Output from PDout channel	Device specific	RO	
0x0052 (82)	Device Temperature	2 octets 2 octets 2 octets 2 octets 2 octets	1(64) 2(48) 3(32) 4(16) 5(0)		Device temperature actual Device min. temperature since powerup Device max. temperature since powerup Device min. temperature during lifetime Device max. temperature during lifetime	IntegerT IntegerT IntegerT IntegerT IntegerT	RO RO RO RO RO	
0x0053 (83)	Device Temperature Threshold	2 octets 2 octets	1(16) 2(0)		Device min. temperature threshold (B01, C01, T01) Device max. temperature threshold (B01, C01, T01)	IntegerT IntegerT	R/W	Saved in non-volatile memory every hour. Events are generated if the device temperature exceeds the thresholds.
0x0057 (87)	Operating Hours	4 octets 4 octets 4 octets	1(64) 2(32) 3(0)	0...(2^32)-1	Operating Hours: device operating hours. Not resettable by user. Operating Hours Maintenance: device operating hours, reset on system command "Confirm Maintenance". Operating Hours Power Up: Time in hours since power up.	UIntegerT UIntegerT UIntegerT	RO RO RO	
0x0024 (36)	Device Status	1 octet		0x00 → Device is operating properly 0x01 → Maintenance Required 0x02 → Out of specification 0x03 → Functional Check 0x04 → Failure	Contains current status of the device	UIntegerT	RO	
0x0025 (37)	Detailed Device Status	3 octets			Information about currently pending Events. Implemented as dynamic list.	UIntegerT	RO	
0x00BE (190)	Excess gain	2 octets		100...900	Excess gain (EG) = 0 if signal is under threshold (B01 LED, C01, T01)	UIntegerT	RO	

*RO = read only, WO = write only, R/W = read/write

Teach-in Parameters								
Index (dec)	Parameter Object Name	Lenght	Subindex (offset)	Value/Range	Description	Data Type	Access*	Remark
0x003A (58)	TI Select	1 octet		0x00 = SSC1 (default, C/Q pin and DO pin)	Selection for Teach-in channel (volatile)	UIntegerT	R/W	C/Q and DO outputs are antivalent. Teach SSC1 equals to teach SSC2
0x003B (59)	TI Result	1 octet	1(0) 2(4) 3(5)	Teach-in State Flag SP1 TP1 Flag SP2 TP1	See IO-Link Smart Sensor Profile	UIntegerT4 BooleanT BooleanT	RO	
0x003C (60)	SSC1 Param	2 octets 2 octets	1(16) 2(0)	0-4095 Not used	Normalized distance (M03) / Switching threshold (W03) / Trimmer value (sensitivity adjustment) (Trimmer models)	UIntegerT	R/W	Saved in non-volatile memory
0x003D (61)	SSC1 Config	1 octet	1(24)	0x00: High Active (default C01, M03, W03) 0x01: Low Active (default B01, T01)	C/Q pin configuration	UIntegerT	R/W	Saved in non-volatile memory
		1 octet	2(16)	0x01: Single Point (default)		UIntegerT		
		2 octets	3(0)	Not used (M03) 0 ..10 Hysteresis (W03) 0 - 1 Hysteresis (Trimmer models)		UIntegerT		
0x003E (62)	SSC2 Param	2 octets 2 octets	1(16) 2(0)	0-4095 Non used	Normalized distance	UIntegerT	R/W	Saved in non-volatile memory
0x003F (63)	SSC2 Config	1 octet	1(24)	0x00: High Active (default B01, T01) 0x01: Low Active (default C01, M03, W03)	DO pin configuration	UIntegerT	R/W	Saved in non-volatile memory
		1 octet	2(16)	0x01: Single Point (default)		UIntegerT		
		2 octets	3(0)	Not used (M03) 0 ..10 Hysteresis (W03) 0 - 1 Hysteresis (Trimmer models)		UIntegerT		
0x0066 (102)	Adjustment mode	1 octet		0x00 = manual (default) 0x01 = IO-Link	Status of trimmer regulation (manual/IO-Link) (B01, C01, T01)	BooleanT	R/W	

*RO = read only, WO = write only, R/W = read/write

Device Specific Parameters								
Index (dec)	Parameter Object Name	Length	Subindex (offset)	Value/Range	Description	Data Type	Access*	Remark
0x0048 (72)	Delay Settings	1 octet	1(64)	0 = no delay (default) 0x2 = Delay ON 0x3 = One Shot 0x4 = Delay OFF	Select Delay mode (ON / OFF/ ONE SHOT)	UIntegerT	R/W	Saved in non-volatile memory
		4 octets	2(32)	0...(2 ³²)-1	Delay ON value = Delay [ms] *1000 / 141 (M03) Delay [ms] *1000 / 45 (W03) Delay [ms] *1000 / 157 (T01/C01/B01 LED emission) Delay [ms] *1000 / 67 (C01 Laser) Delay [ms] *1000 / 70 (B01 Laser)	UIntegerT	R/W	
		4 octets	3(0)	0...(2 ³²)-1	Delay OFF value = Delay [ms] *1000 / 141 (M03) Delay [ms] *1000 / 45 (W03) Delay [ms] *1000 / 157 (T01/C01/B01 LED emission) Delay [ms] *1000 / 67 (C01 Laser) Delay [ms] *1000 / 70 (B01 Laser)	UIntegerT	R/W	
0x00B4 (180)	Output type	1 octet	1(8)	0x01 = PNP (default) 0x03 = Push Pull ⁽¹⁾	Output type of C/Q pin when in SIO mode	UIntegerT	R/W	Saved in non-volatile memory
		1 octet	2(0)	0x01 = PNP (default) 0x02 = NPN 0x03 = Push Pull	Output type of DO pin	UIntegerT	R/W	

⁽¹⁾ The No Output configured in Push Pull mode with an NPN load does not reactivate after a short circuit condition. Remove the short circuit condition and cycle power to the sensor.

Standard Command						
Index (dec)	Command Name	Length	Value (dec)	Description	Access*	
0x0002 (2)	SP1 Single Value Teach	1 octet	0x41 (65)	Acquisition EASY (refer to User's Manual) (M03, W03) / Teach Set Point (B01, C01, T01)	WO	
0x0002 (2)	SP1 Teach TP1	1 octet	0x43 (67)	Acquisition FINE: Mark Detection (refer to User's Manual) (W03)	WO	
0x0002 (2)	SP1 Teach TP2	1 octet	0x44 (68)	Acquisition FINE: Background Detection (refer to User's Manual) (W03)	WO	
0x0002 (2)	Teach FINE	1 octet	0x4B (75)	Acquisition FINE (refer to User's Manual) (M03)	WO	
0x0002 (2)	Teach CANCEL	1 octet	0x4F (79)	Exit from teach FAIL status (M03) / Exit from Fine detection (W03)	WO	
0x0002 (2)	Restore Factory Settings	1 octet	0x82 (130)	Restore factory settings (Device Access Locks, Application Specific Tag, Function Tag, Location Tag, SSC1 Param, SSC2 Param, Delay Settings, Output Type, Adjust Mode)	WO	
0x0002 (2)	Confirm Maintenance	1 octet	0xA5 (165)	Reset Maintenance parameters (Operating Hours Maintenance, Minimum device temperature since powerup, Maximum device temperature since powerup, Device Status, Detailed Device Status)	WO	
0x0002 (2)	Disable IO-Link adjustment	1 octet	0xAB (171)	Disable teach via IO-Link, re-enable trimmer adjustment (B01, C01, T01)	WO	
0x0002 (2)	Start / Stop Ping	1 octet	0xAF (175)	Feature to identify the sensor by yellow led blinking	WO	

Events					
Event code (dec)	Event name	Event mode	Event type	Device status	Remarks
0x4220 (16928)	Temperature underrun	Appears / Disappears	Warning	Out of specification	only B01, C01, T01
0x4210 (16912)	Temperature overrun	Appears / Disappears	Warning	Out of specification	
0x5100 (20736)	General power supply fault	Appears / Disappears	Error	Failure	
0x7710 (30480)	Short circuit - Check installation	Appears / Disappears	Error	Failure	
0x8C40 (35904)	Maintenance required - Lens cleaning	Appears / Disappears	Notification	Maintenance required	only B01
0x8CA0 (36000)	Laser fault	Appears / Disappears	Error	Failure	only Laser models

PROCESS DATA

Process Data Output							
Byte 0							
7	6	5	4	3	2	1	0
Not used							TRANSDUCER DISABLE
Process Data Input							
Byte 2							
23	22	21	20	19	18	17	16
PDV1 (Normalized distance (M03) ⁽²⁾ / LIGHT RECEIVED (W03, B01, C01, T01) (MSB))							
Byte 1							
15	14	13	12	11	10	9	8
PDV1 (Normalized distance (M03) ⁽²⁾ / LIGHT RECEIVED (W03, B01, C01, T01) (LSB))							
Byte 0							
7	6	5	4	3	2	1	0
Not used				Not used (W03, M03, T01), Stability (C01) Alarm (B01)	TEACH-IN	SSC2 (DO pin)	SSC1 (C/Q pin)

⁽²⁾ Process data will not be valid in case of out-of-range values.

DEVICE VARIANT COLLECTION

Product name	Product ID	Product text	Device ID
S5N-PA-5-C01-OZ	02210	Diffuse proximity	2
S5N-MA-5-C01-OZ	22200	Diffuse proximity	
S5N-PA-5-M03-OZ	02230	Background suppression	3
S5N-MA-5-M03-OZ	22170	Background suppression	
S5N-PA-5-W03-OZ	02240	Mark reader	4
S5N-PL-5-C01-OZ	02260	Diffuse proximity laser	5
S5N-ML-5-C01-OZ	22190	Diffuse proximity laser	
S5N-PL-5-B01-OZ	02250	Reflex polarized laser	6
S5N-ML-5-B01-OZ	22180	Reflex polarized laser	
S5N-PA-5-B01-OZ	02200	Reflex polarized	7
S5N-MA-5-B01-OZ	22160	Reflex polarized	
S5N-PA-5-T01-OZ	02220	Reflex transparent	8

EN	CE Compliance
<p>CE marking states the compliance of the product with essential requirements listed in the applicable European directive. Since the directives and applicable standards are subject to continuous updates, and since the manufacturer promptly adopts these updates, therefore the EU declaration of conformity is a living document. The EU declaration of conformity is available for competent authorities and customers through the manufacturer's commercial reference contacts. Since April 20th, 2016 the main European directives applicable to the products require inclusion of an adequate analysis and assessment of the risk(s). This evaluation was carried out in relation to the applicable points of the standards listed in the Declaration of Conformity. These products are mainly designed for integration purposes into more complex systems. For this reason, it is under the responsibility of the system integrator to do a new risk assessment regarding the final installation.</p> <p>Warning This is a Class A product. In a domestic environment this product may cause radio interference in which case the user may be required to take adequate measures.</p>	

IT	Conformità CE
<p>La marcatura CE dichiara la conformità del prodotto con i requisiti essenziali elencati nella direttiva europea applicabile. Essendo le direttive e le normative applicabili soggette a continui aggiornamenti, e dato che il costruttore adotta immediatamente tali aggiornamenti, la dichiarazione di conformità CE è un documento vivo. La dichiarazione di conformità CE è disponibile per le autorità competenti e i clienti tramite i contatti commerciali di riferimento al costruttore. Dal 20 aprile 2016, le principali direttive europee applicabili ai prodotti richiedono l'inserimento di un'adeguata analisi e valutazione dell/i rischi(o). Tale valutazione è stata realizzata in relazione ai punti applicabili delle normative elencate nella Dichiarazione di Conformità. Questi prodotti sono progettati principalmente per essere integrati in sistemi più complessi. Per questo motivo, l'integratore di sistemi è responsabile della realizzazione di una nuova valutazione dei rischi riguardante l'installazione finale.</p> <p>Attenzione Si tratta di un prodotto di Classe A. In un ambiente domestico questo prodotto può generare interferenze radio. In tal caso è necessario prendere le dovute misure.</p>	

DE	EG-Konformität
<p>Die CE-Kennzeichnung bestätigt die Konformität des Produkts mit den wesentlichen Anforderungen der geltenden europäischen Richtlinien. Da die Richtlinien und anwendbaren Normen laufend aktualisiert werden und der Hersteller diese Aktualisierungen umgehend übernimmt, ist die EU-Konformitätserklärung ein fortschreitendes Dokument. Die EU-Konformitätserklärung ist für zuständige Behörden und Kunden über die Handelskontakte von dem Hersteller erhältlich. Seit dem 20. April 2016 erfordern die wichtigsten für diese Produkte anwendbaren Europäischen Richtlinien die Integration einer angemessenen Analyse und der Bewertung der Risiken. Diese Bewertung wird in Bezug auf die anwendbaren Punkte der in der Konformitätserklärung aufgelisteten Normen durchgeführt. Diese Produkte werden in erster Linie für die Integration in komplexere Systeme ausgelegt. Aus diesem Grund liegt es in der Verantwortung des Systemintegrators, eine neue Risikobewertung der Endinstallation vorzunehmen.</p> <p>Warnung Dies ist ein Produkt nach Klasse A. In einem häuslichen Umfeld kann dieses Produkt Funkstörungen auslösen, gegebenenfalls hat der Benutzer dann angebrachte Maßnahmen zu ergreifen.</p>	

FR	Conformité CE
<p>La marque CE indique la conformité du produit aux exigences essentielles énoncées dans la directive européenne applicable. Les directives et les normes applicables sont sujettes à des mises à jour de manière continue et le constructeur adopte rapidement ces mises à jour ; la déclaration de conformité UE est par conséquent un document vivant. La déclaration de conformité UE est disponible aux autorités compétentes et aux clients à travers les interlocuteurs commerciaux de référence des constructeurs. Depuis le 20 Avril 2016 les principales directives européennes applicables aux produits exigent l'inclusion d'une analyse et d'une évaluation adéquates du/des risque/s. Cette évaluation a été réalisée en relation avec les points applicables des normes indiquées dans la Déclaration de Conformité. Ces produits sont principalement conçus à des fins d'intégration dans des systèmes plus complexes. Pour cette raison, il est de la responsabilité de l'intégrateur de système d'effectuer une nouvelle évaluation des risques concernant l'installation finale.</p> <p>Avertissement Ceci est un produit de Classe A. Dans un environnement domestique, ce produit peut provoquer des interférences radio auquel cas l'utilisateur peut se trouver dans l'obligation de prendre des mesures adéquates.</p>	

ES	Conformidad CE
<p>La marca CE establece la conformidad del producto con los requisitos fundamentales enumerados en la directiva europea aplicable. Debido a que las directivas y normativas aplicables están sujetas a actualización continua, como el constructor adopta estas actualizaciones de inmediato, la declaración de conformidad UE es un documento activo. La declaración de conformidad UE está disponible para las autoridades competentes y para los clientes a través de los contactos comerciales de referencia del constructor. Desde el 20 de abril de 2016, las principales directivas europeas aplicables a los productos exigen la inclusión de un idóneo análisis y evaluación de riesgos. Esta evaluación ha sido efectuada sobre los puntos aplicables de la normativa indicada en la Declaración de Conformidad. Estos productos han sido diseñados a fin de ser integrados en sistemas más complejos. Por ello, es responsabilidad del integrador del sistema efectuar una nueva evaluación de riesgos relativa a la instalación final.</p> <p>Advertencia Este es un producto de Clase A. En un entorno doméstico, este producto puede causar interferencias radioeléctricas; en este caso, el usuario debería tomar medidas adecuadas.</p>	

NL	EU-conformiteitsverklaring
<p>Met de CE-markering wordt verklaard dat het product voldoet aan de essentiële eisen zoals vermeld in de toepasselijke Europese richtlijnen. Daar de richtlijnen en de toepasselijke normen onderhevig zijn aan voortdurende aanpassingen, en de fabrikant deze aanpassingen direct toepast, is de EU-conformiteitsverklaring een levend document. De EU-conformiteitsverklaring is beschikbaar voor bevoegde autoriteiten en klanten via contactgegevens voor commerciële referentie. Sinds 20 april 2016 vereisen de belangrijkste Europese richtlijnen de inclusie van een adequate risicoanalyse- en beoordeling. Deze beoordeling werd uitgevoerd met betrekking tot de toepasselijke punten van de normen zoals vermeld in de Conformiteitsverklaring. Deze producten zijn voornamelijk ontworpen voor integratie in complexere systemen. Om deze reden is het de verantwoordelijkheid van de systeemintegrator om een nieuwe risicobeoordeling uit te voeren met betrekking tot de definitieve installatie.</p> <p>Waarschuwing Dit is een Klasse A product. In een woonomgeving kan dit product radiostoring veroorzaken, in welk geval de gebruiker mogelijk verplicht is om adequate maatregelen te treffen.</p>	