

Brass and stainless steel magnet drive rotary vane pumps TH 500-1000 series



Find out more

The Fluid-o-Tech® magnetic drive rotary vane pumps range widens with the introduction of the TH series which combines the larger flow rate (500 to 1000 l/h at 1450 rpm or 160 to 330 GPH at 1725 rpm) with the added benefit of the magnetic coupling:

- longer service life
- low maintenance
- smooth transmission
- totally sealed body
- less power consumption

The rare earths magnet grants high performance and perfect alignment between the pump and the motor, extending the life of the unit. The absence of friction, usually caused by the rotation of the mechanical seal against the ceramic seat, allows a more efficient operation and therefore a low power consumption. The Rotoflow® TH series pumps offer multiple options to configure the product to the specific need of each customer.

The housing is available in AISI 303 or brass. The internal components include AISI 303 rotor, carbon graphite pumping chamber and NBR seals.

Maximum operative temperature: 70 °C (158 F).

Available upon request:

- Built-in relief valve
- Viton®/EPDM seals



MAIN APPLICATIONS

- Cooling systems
- Booster systems
- Water treatment
- Solar systems

TECHNICAL INFORMATION

Pump housing material	Brass or stainless steel	Speed limit	1725 rpm
Pumping chamber	Carbon graphite	Max static pressure	20 bar/290 psi
Ports	1/2" GAS or NPT	Pump weight	2.1 kg (4.6 lb)

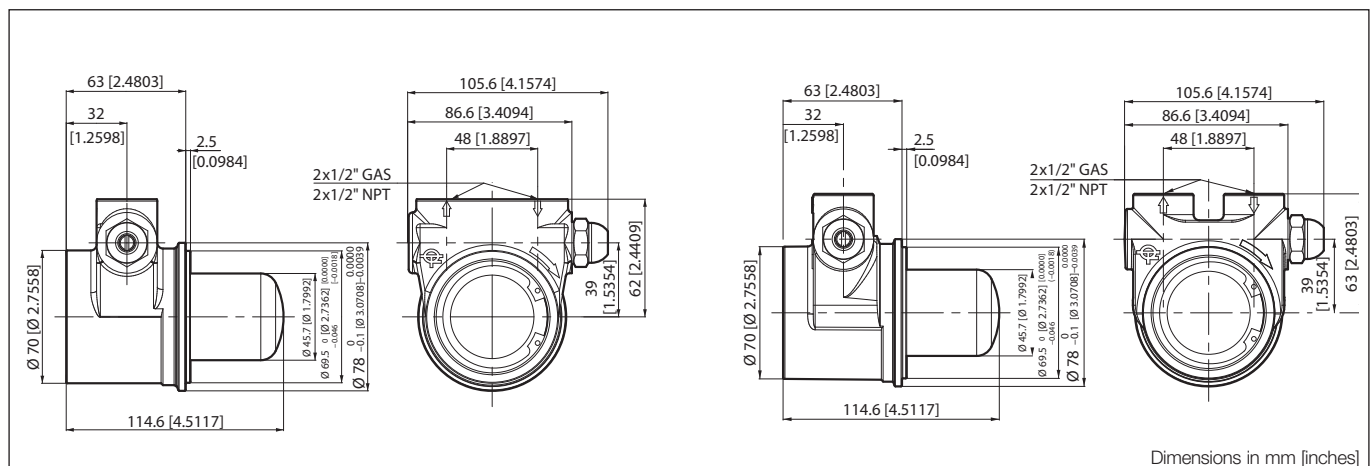

Brass and stainless steel magnet drive rotary vane pumps TH 500-1000 series

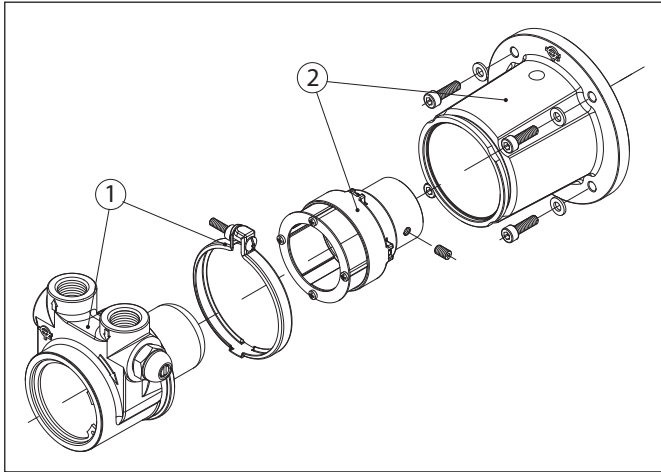

POS	DESCRIPTION	CODE
1	TH series pump	
2	M80-B14 frame motor mounting assembly	THBS80C
	NEMA 56C frame motor mounting assembly	THBS5BC

MODEL	RELIEF VALVE	HOUSING	FIGURE
THSS500A	NO	STAINLESS STEEL	A-A
THSS600A			B-B
THSS700A			C-C
THSS800A			D-D
THSS900A			E-E
THSS1000A			F-F
THSS501A	STANDARD	STAINLESS STEEL	A-A
THSS601A			B-B
THSS701A			C-C
THSS801A			D-D
THSS901A			E-E
THSS1001A			F-F
THOT500A	NO	BRASS	A-A
THOT600A			B-B
THOT700A			C-C
THOT800A			D-D
THOT900A			E-E
THOT1000A			F-F
THOT501A	STANDARD	BRASS	A-A
THOT601A			B-B
THOT701A			C-C
THOT801A			D-D
THOT901A			E-E
THOT1001A			F-F

Flow rate

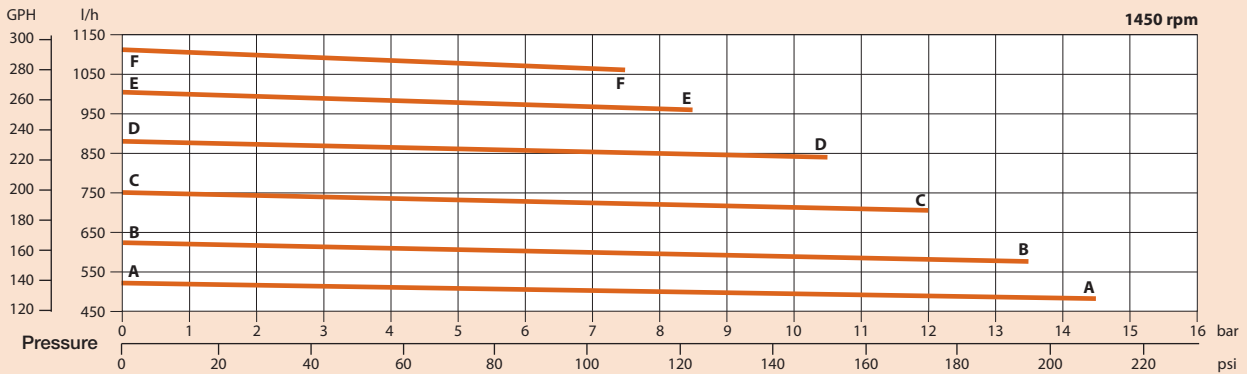

Flow rate

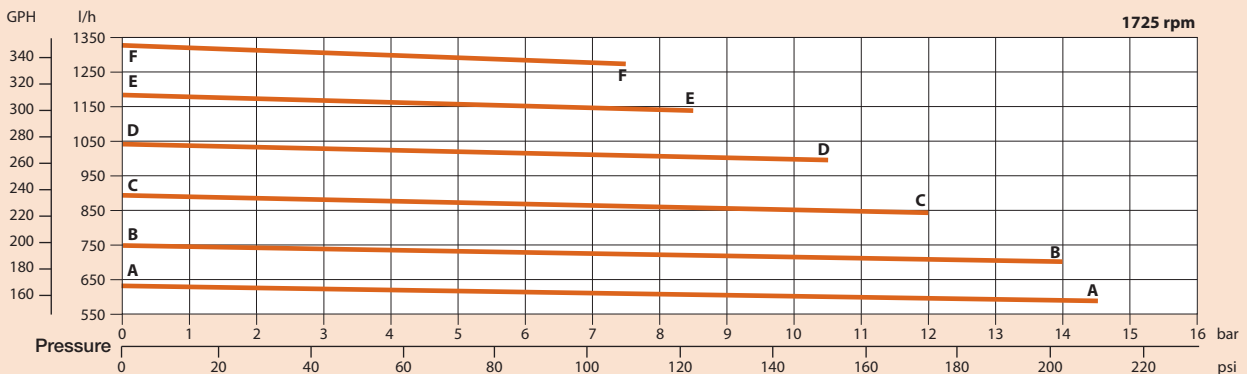

Note: Characteristics with water at 20 °C (68 F) and without bypass - Use filter before pump inlet not larger than 20 microns. For applications involving other fluids, high temperatures, unusual processing conditions or speed higher than 1725 rpm consult the factory or an authorized Fluid-o-Tech distributor.

Fluid-o-Tech reserves the right to alter the specifications indicated in this catalogue at any time and without prior notice.

Fluid-o-Tech srl
Via Leonardo da Vinci, 40
20094 Corsico, Milano, Italy
Tel. +39 02 9995 01
Fax +39 02 9995 0999
info@fluidotech.it

Fluid-o-Tech Int'l Inc.
161 Atwater St.,
06479 Plantsville CT (USA)
Tel. +1 (860) 276 9270
Fax +1 (860) 620 0193
info@fluid-o-tech.com

Fluid-o-Tech Int'l Inc. Japan
203, 2-17-19, Ebara, Shinagawa
Tokyo 142-0063, Japan
Tel. +81 (0) (3) 3783 9660
Fax +81 (0) (3) 3783 9661
k.kato@fluidotech.com

Fluid-o-Tech Asia (Beijing) Co., Ltd
Jingwei Industrial Zone,
Beifang Huairou, Beijing, 101400, PRC
Tel. +86 (0) (10) 6168 4650
Fax +86 (0) (10) 6168 4651
info@fluidotech-asia.com