



TL50
Contrast sensor

INSTRUCTION MANUAL

CONTROLS

- OUT LED (yellow)**
The yellow LED indicates the output status.
 - READY LED (green)**
During functioning, the green LED permanently ON indicates a normal operating condition; fast blinking indicates an output overload condition.
 - DELAY LED (orange)**
The orange LED ON indicates the timing function activation on the digital output.
 - MARK PUSH-BUTTON**
The mark detection procedure is activated by pressing MARK push-button.
 - BKGD PUSH-BUTTON**
The background detection procedure is activated by pressing BKGD push-button.
- See the "SETTING" paragraph for setup procedure indications.



INSTALLATION

- The sensor can be positioned using threaded M5 holes with max. 6 mm depth.
Do not apply excessive torque when adjusting (max 2.2 Nm).
- The operating distance is measured starting from the front surface of the sensor optics.
- The reading direction can be changed inverting the cap and lens.
Mark detection on a reflective surface is improved adjusting the beam direction to 5° ... 20° from surface axis.

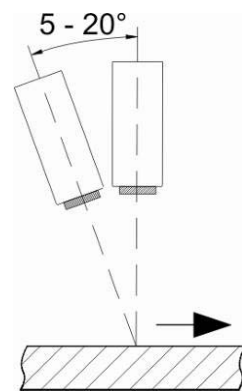

CONNECTIONS

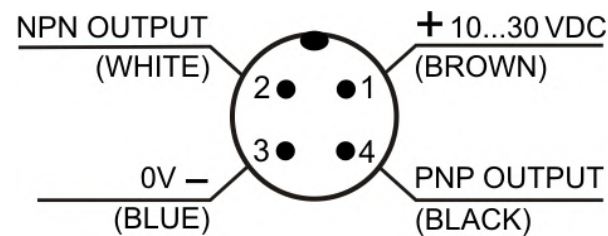

DIMENSIONS

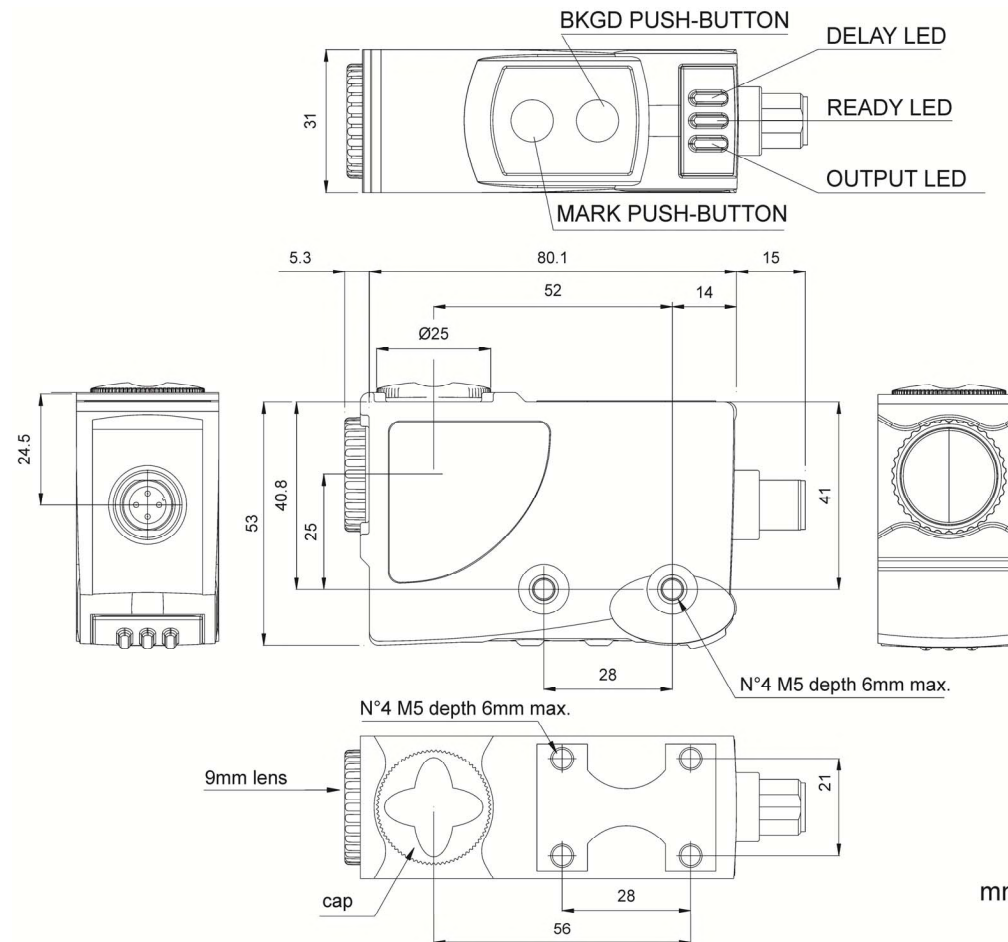

TECHNICAL DATA

Power supply:	10...30 VDC limit values - Class 2 (UL508)
Ripple:	2 Vpp max.
Current consumption (output current excluded):	50 mA max. @ 24Vcc
Output:	1 PNP output 1 NPN output
Output current:	100 mA max.
Output saturation voltage:	≤ 2 V
Response time:	33 μs
Switching frequency:	15 kHz
Delay:	0 / 20 ms selectable (default configuration without delay)
Dark/light selection	automatic
Indicators:	OUT LED (yellow) / READY LED (green)/DELAY LED (orange)
Push-buttons:	MARK and BKGD push-buttons
DARK/LIGHT selection:	Automatic (default configuration LIGHT mode)
Operating temperature:	-10 ... 55 °C
Storage temperature:	-20 ... 70 °C
Dielectric strength:	500 VAC 1 min., between electronics and housing
Insulating resistance:	>20 MΩ 500 Vdc, between electronics and housing
Operating distance:	9 mm
Depth of field:	± 3 mm
Minimum spot dimension:	1.5x5 mm @ 9 mm
Emission type:	BLUE (465 nm) / GREEN (520 nm) / RED (630 nm) with automatic selection
Ambient light rejection:	According to EN 60947-5-2
Vibrations:	0.5 mm amplitude, 10 ... 55 Hz frequency, for each axis (EN60068-2-6)
Shock resistance:	11 ms (30 G) 6 shock for each axis (EN60068-2-27)
Housing material:	ABS
Lens material:	PMMA
Mechanical protection:	IP67
Connections:	M12 4-pole connector
Weight:	90 g. max.
AtEx 2014/34/EU:	II 3G EX nA II T6 ; II 3D EX tD A22 IP67 T85°C

SETTING

DETECTION (MARK-BACKGROUND)

- Position mark in front of the sensor light spot and press MARK push-button until the READY LED (green) turns OFF.
The sensor detects the mark alternating the red, green and blue emissions. Avoid mark movements during this phase.
- Position the background in front of the sensor light spot and press BKGD push-button; the sensor detects the mark alternating the red, green and blue emissions. Avoid background movements during this phase.

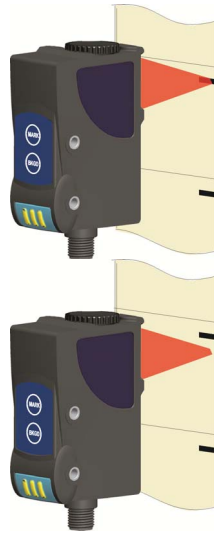

The DARK/LIGHT operating mode is automatically selected by the sensor.
Dark mark - light background = Dark mode.
Light mark - dark background = Light mode.

- If the READY LED (green) is permanently ON, the detection is successful.
- If the LED blinks slowly, the detection has failed due to insufficient contrast.
- The sensor returns to the previous setting by pressing one of the two push-buttons.

DELAY SETTING

The DELAY extends to 20ms the minimum duration of the active output allowing the slower interfacing systems to detect shorter pulses. The active delay is signalled by the corresponding orange LED ON.

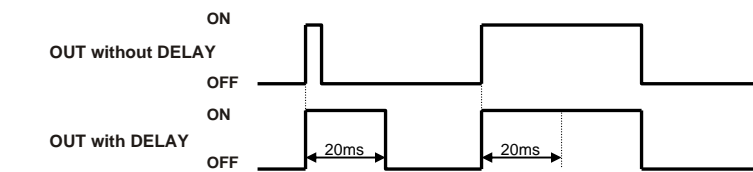

Delay activation

Press MARK and BKGD push-buttons contemporaneously for 2 sec. until the DELAY LED turns ON.

Delay deactivation

Press MARK and BKGD push-buttons contemporaneously for 2 sec. until the DELAY LED turns OFF.



OUTPUT OVERLOAD

The digital output overload is signalled by the rapid blinking of the READY LED.

The sensors are NOT safety devices, and so MUST NOT be used in the safety control of the machines where installed.

Datasensing S.r.l.
Strada S. Caterina 235 - 41122 Modena - Italy
Tel: +39 059 420411 - Fax: +39 059 253973 - www.datasensing.com

The warranty period for this product is 36 months. See General Terms and Conditions of Sales for further details.



For information about the disposal of Waste Electrical and Electronic Equipment (WEEE), please refer to the website at www.datasensing.com.

© 2007 - 2022 Datasensing S.r.l. • ALL RIGHTS RESERVED. • Without limiting the rights under copyright, no part of this documentation may be reproduced, stored in or introduced into a retrieval system, or transmitted in any form or by any means, or for any purpose, without the express written permission of Datasensing S.r.l. • Datasensing and the Datasensing logo are trademarks of Datasensing S.r.l. • Datalogic and the Datalogic logo are registered trademarks of Datalogic S.p.A. in many countries, including the U.S and the E.U.

