

LOVATO ELECTRIC S.P.A.

24020 GORLE (BERGAMO) ITALIA
VIA DON E. MAZZA, 12
TEL. 035 4282111
E-mail info@LovatoElectric.com
Web www.LovatoElectric.com

GB VARIABLE SPEED DRIVES
Instruction manual
VLB3

WARNING!

- Carefully read the manual before the installation or use.
- This equipment is to be installed by qualified personnel, complying to current standards, to avoid damages or safety hazards.
- Before any maintenance operation on the device, remove all the voltages from measuring and supply inputs and short-circuit the CT input terminals.
- The manufacturer cannot be held responsible for electrical safety in case of improper use of the equipment.
- Products illustrated herein are subject to alteration and changes without prior notice. Technical data and descriptions in the documentation are accurate, to the best of our knowledge, but no liabilities for errors, omissions or contingencies arising there from are accepted.
- A circuit breaker must be included in the electrical installation of the building. It must be installed close by the equipment and within easy reach of the operator. It must be marked as the disconnecting device of the equipment: IEC/EN 61010-1 § 6.11.3.1.
- Clean the device with a soft dry cloth; do not use abrasives, liquid detergents or solvents.

ATTENTION !

- Lire attentivement le manuel avant toute utilisation et installation.
- Ces appareils doivent être installés par un personnel qualifié, conformément aux normes en vigueur en matière d'installations, afin d'éviter de causer des dommages à des personnes ou choses.
- Avant toute intervention sur l'instrument, mettre les entrées de mesure et d'alimentation hors tension et court-circuiter les transformateurs de courant.
- Le constructeur n'assume aucune responsabilité quant à la sécurité électrique en cas d'utilisation impropre du dispositif.
- Les produits décrits dans ce document sont susceptibles d'évoluer ou de subir des modifications à n'importe quel moment. Les descriptions et caractéristiques techniques du catalogue ne peuvent donc avoir aucune valeur contractuelle.
- Un interrupteur ou disjoncteur doit être inclus dans l'installation électrique du bâtiment. Celui-ci doit se trouver tout près de l'appareil et l'opérateur doit pouvoir y accéder facilement. Il doit être marqué comme le dispositif d'interruption de l'appareil : IEC/EN 61010-1 § 6.11.3.1.
- Nettoyer l'appareil avec un chiffon doux, ne pas utiliser de produits abrasifs, détergents liquides ou solvants.

ACHTUNG!

- Dieses Handbuch vor Gebrauch und Installation aufmerksam lesen.
- Zur Vermeidung von Personen- und Sachschäden dürfen diese Geräte nur von qualifiziertem Fachpersonal und unter Befolgung der einschlägigen Vorschriften installiert werden.
- Vor jedem Eingriff am Instrument die Spannungszufuhr zu den Messeingängen trennen und die Stromwandler kurzschließen.
- Bei zweckwidrigem Gebrauch der Vorrichtung übernimmt der Hersteller keine Haftung für die elektrische Sicherheit.
- Die in dieser Broschüre beschriebenen Produkte können jederzeit weiterentwickelt und geändert werden. Die im Katalog enthaltenen Beschreibungen und Daten sind daher unverbindlich und ohne Gewähr.
- In die elektrische Anlage des Gebäudes ist ein Ausschalter oder Trennschalter einzubauen. Dieser muss sich in unmittelbarer Nähe des Geräts befinden und vom Bediener leicht zugänglich sein. Er muss als Trennvorrichtung für das Gerät gekennzeichnet sein: IEC/EN 61010-1 § 6.11.3.1.
- Das Gerät mit einem weichen Tuch reinigen, keine Scheuermittel, Flüssigreiniger oder Lösungsmittel verwenden.

ADVERTENCIA

- Leer atentamente el manual antes de instalar y utilizar el regulador.
- Este dispositivo debe ser instalado por personal cualificado conforme a la normativa de instalación vigente a fin de evitar daños personales o materiales.
- Antes de realizar cualquier operación en el dispositivo, desconectar la corriente de las entradas de alimentación y medida, y cortocircuitar los transformadores de corriente.
- El fabricante no se responsabilizará de la seguridad eléctrica en caso de que el dispositivo no se utilice de forma adecuada.
- Los productos descritos en este documento se pueden actualizar o modificar en cualquier momento. Por consiguiente, las descripciones y los datos técnicos aquí contenidos no tienen valor contractual.
- La instalación eléctrica del edificio debe disponer de un interruptor o disyuntor. Éste debe encontrarse cerca del dispositivo, en un lugar al que el usuario pueda acceder con facilidad. Además, debe llevar el mismo marcado que el interruptor del dispositivo (IEC/EN 61010-1 § 6.11.3.1).
- Limpiar el dispositivo con un trapo suave; no utilizar productos abrasivos, detergentes líquidos ni disolventes.

UPOZORNĚNÍ

- Návod se pozorně pročtěte, než začnete regulátor instalovat a používat.
- Tato zařízení smí instalovat kvalifikovaní pracovníci v souladu s platnými předpisy a normami pro předcházení úrazu osob či poškození věcí.
- Před jakýmkoli zásahem do přístroje odpojte měřicí a napájecí vstupy od napětí a zkratujte transformátory proudu.
- Výrobce nenese odpovědnost za elektrickou bezpečnost v případě nevhodného používání regulátoru.
- Výrobky popsané v tomto dokumentu mohou kdykoli projít úpravami či dalším vývojem. Popisy a údaje uvedené v katalogu nemají proto žádnou smluvní hodnotu.
- Spínač či odpojovač je nutno zabudovat do elektrického rozvodu v budově. Musejí být nainstalované v těsné blízkosti přístroje a snadno dostupné pracovníku obsluhy. Je nutno ho označit jako vypínací zařízení přístroje: IEC/EN 61010-1 § 6.11.3.1.
- Přístroj čistěte měkkou utěrkou, nepoužívejte abrazivní produkty, tekutá čistidla či rozpouštědla.

AVERTIZARE!

- Cititi cu atenție manualul înainte de instalare sau utilizare.
- Acest echipament va fi instalat de personal calificat, în conformitate cu standardele actuale, pentru a evita deteriorări sau pericolele.
- Înainte de efectuarea oricărei operațiuni de întreținere asupra dispozitivului, îndepărtați toate tensiunile de la intrările de măsurare și de alimentare și scurtcircuitați bornele de intrare CT.
- Producătorul nu poate fi considerat responsabil pentru siguranța electrică în caz de utilizare incorectă a echipamentului.
- Produsele ilustrate în prezentul sunt supuse modificărilor și schimbărilor fără notificare anterioară. Datele tehnice și descrierile din documentație sunt precise, în măsura cunoștințelor noastre, dar nu se acceptă nicio răspundere pentru erorile, omisiunile sau evenimentele neprevăzute care apar ca urmare a acestora.
- Trebuie inclus un disjuncteur în instalația electrică a clădirii. Acesta trebuie instalat aproape de echipament și într-o zonă ușor accesibilă operatorului. Acesta trebuie marcat ca fiind dispozitivul de deconectare al echipamentului: IEC/EN 61010-1 § 6.11.3.1.
- Curățați instrumentul cu un material textil moale și uscat; nu utilizați substanțe abrazive, detergenți lichizi sau solvenți.

ATTENZIONE!

- Leggere attentamente il manuale prima dell'utilizzo e l'installazione.
- Questi apparecchi devono essere installati da personale qualificato, nel rispetto delle vigenti normative impiantistiche, allo scopo di evitare danni a persone o cose.
- Prima di qualsiasi intervento sullo strumento, togliere tensione dagli ingressi di misura e di alimentazione e cortocircuitare i trasformatori di corrente.
- Il costruttore non si assume responsabilità in merito alla sicurezza elettrica in caso di utilizzo improprio del dispositivo.
- I prodotti descritti in questo documento sono suscettibili in qualsiasi momento di evoluzioni o di modifiche. Le descrizioni ed i dati a catalogo non possono pertanto avere alcun valore contrattuale.
- Un interruttore o disgiuntore va compreso nell'impianto elettrico dell'edificio. Esso deve trovarsi in stretta vicinanza dell'apparecchio ed essere facilmente raggiungibile da parte dell'operatore. Deve essere marchiato come il dispositivo di interruzione dell'apparecchio: IEC/EN 61010-1 § 6.11.3.1.
- Pulire l'apparecchio con panno morbido, non usare prodotti abrasivi, detergenti liquidi o solventi.

UWAGA!

- Przed użyciem i instalacją urządzenia należy uważnie przeczytać niniejszą instrukcję.
- W celu uniknięcia obrażeń osób lub uszkodzenia mienia tego typu urządzenia muszą być instalowane przez wykwalifikowany personel, zgodnie z obowiązującymi przepisami.
- Przed rozpoczęciem jakichkolwiek prac na urządzeniu należy odłączyć napięcie od wejść pomiarowych i zasilania oraz zwrzeć zaciski przekładnika prądowego.
- Producent nie przyjmuje na siebie odpowiedzialności za bezpieczeństwo elektryczne w przypadku niewłaściwego użytkowania urządzenia.
- Produkty opisane w niniejszym dokumencie mogą być w każdej chwili udoskonalone lub zmodyfikowane. Opisy oraz dane katalogowe nie mogą mieć w związku z tym żadnej wartości umownej.
- W instalacji elektrycznej budynku należy uwzględnić przełącznik lub wyłącznik automatyczny. Powinien on znajdować się w bliskim sąsiedztwie urządzenia i być łatwo osiągalny przez operatora. Musi być oznaczony jako urządzenie służące do wyłączania urządzenia: IEC/EN 61010-1 § 6.11.3.1.
- Urządzenie należy czyścić miękką szmatką, nie stosować środków ściernych, płynnych detergentów lub rozpuszczalników.

警告!

- 安装或使用前，请仔细阅读本手册。
- 本设备只能由合格人员根据现行标准进行安装，以避免造成损坏或安全危害。
- 对设备进行任何维护操作前，请移除测量输入端和电源输入端的所有电压，并短接 CT 输入端。
- 制造商不负责因设备使用不当导致的电气安全问题。
- 此处说明的产品可能会有变更，恕不提前通知。我们竭力确保本文件中技术数据和说明的准确性，但对于错误、遗漏或由此产生的意外事件概不负责。
- 建筑电气系统中必须装有断路器。断路器必须安装在靠近设备且方便操作人员触及的地方。必须有断路器标记为设备的断开装置：IEC/EN 61010-1 § 6.11.3.1
- 请使用柔软的干布清洁设备；切勿使用研磨剂、洗涤剂或溶剂。

ПРЕДУПРЕЖДЕНИЕ!

- Прежде чем приступать к монтажу или эксплуатации устройства, внимательно ознакомьтесь с содержанием настоящего руководства.
- Во избежание травм или материального ущерба монтаж должен осуществляться только квалифицированным персоналом в соответствии с действующими нормативами.
- Перед проведением любых работ по техническому обслуживанию устройства необходимо обесточить все измерительные и питающие входные контакты, а также замкнуть накоротко входные контакты трансформатора тока (ТТ).
- Производитель не несет ответственность за обеспечение электробезопасности в случае ненадлежащего использования устройства.
- Издания, описанные в настоящем документе, в любой момент могут подвергнуться изменениям или усовершенствованиям. Поэтому каталожные данные и описания не могут рассматриваться как действительные с точки зрения контрактов
- Электрическая сеть здания должна быть оснащена автоматическим выключателем, который должен быть расположен вблизи оборудования в пределах доступа оператора. Автоматический выключатель должен быть промаркирован как отключающее устройство оборудования: IEC/EN 61010-1 § 6.11.3.1.
- Очистку устройства производить с помощью мягкой сухой ткани, без применения абразивных материалов, жидких моющих средств или растворителей.

DİKKAT!

- Montaj ve kullanımdan önce bu el kitabını dikkatlice okuyunuz.
- Bu aparatlar kişilere veya nesnelere zarar verme ihtimaline karşı yürürlükte olan sistem kurma normlarına göre kalifiye personel tarafından monte edilmelidir
- Aparata (cihaz) herhangi bir müdahalede bulunmadan önce ölçüm girişlerinde gerilimi kesip akım transformatorlerinde kısa devre yaptırınız.
- Üretici aparatın hatalı kullanımından kaynaklanan elektriksel güvenliğe ait sorumluluk kabul etmez.
- Bu dokümanda tarif edilen ürünler her an evrimlere veya değişimlere açıktır. Bu sebeple katalogdaki tarif ve değerler herhangi bir bağlayıcı değeri haiz değildir.
- Binanın elektrik sisteminde bir anahtar veya şalter bulunmalıdır. Bu anahtar veya şalter operatörün kolaylıkla ulaşabileceği yakın bir yerde olmalıdır. Aparatı (cihaz) devreden çıkartma görevi yapan bu anahtar veya şalterin markası: IEC/EN 61010-1 § 6.11.3.1.
- Aparatı (cihaz) sıvı deterjan veya solvent kullanarak yumuşak bir bez ile siliniz aşındırıcı temizlik ürünleri kullanmayınız.



CONTENTS

1	SAFETY INFORMATION	7
1.1	INTENDED USE OF VSD	7
1.2	EXAMPLES OF UNINTENDED USE	7
1.3	QUALIFIED PERSONNEL	7
1.4	SIGNAL WORDS AND SYMBOLS	7
1.4.1	ELEMENTS OF A SAFETY MESSAGE	7
1.5	WARNING LABELS ON VSD	7
1.6	BASIC SAFETY MEASURES	8
1.7	ELECTROMAGNETIC INFLUENCES	8
1.8	RESIDUAL HAZARDS	9
2	PRODUCT DESCRIPTION	10
3	MOUNTING	11
3.1	DIMENSIONS AND MECHANICAL INSTALLATION	11
3.1.1	DIMENSION 0,37KW	11
3.1.2	DIMENSION 0,75KW	11
3.1.3	DIMENSION 1,5KW...2,2KW	12
3.1.4	DIMENSIONS 4KW...5,5KW	12
3.1.5	DIMENSIONS 7,5KW ... 11KW	13
3.1.6	DIMENSIONS 15KW ... 22KW	13
3.1.7	DIMENSIONS 30KW...45KW	14
3.1.8	DIMENSIONS 55KW...75KW	14
3.1.9	DIMENSIONS 90KW...110KW	15
3.2	ELECTRICAL INSTALLATION	16
3.2.1	CONNECTION TO THE 400 V SYSTEM	16
3.2.1.1	WIRING DIAGRAM	16
3.2.1.2	FUSES AND CABLE CROSS-SECTIONS	17
3.2.1.3	DC-BUS voltage operative range	22
3.2.1.4	Data of control connections	23
3.2.2	CONNECTION OF THE SAFETY MODULE VLBXSM	26
3.2.2.1	Important notes	26
3.2.2.2	Connection plan	26
3.2.2.3	Terminal Data	26
4	COMMISSIONING	27
4.1	OPERATING INTERFACES	27
4.1.1	OVERVIEW	27
4.1.2	KEYPAD	27
4.1.2.1	KEYPAD OPERATING MODE	27
4.1.2.2	KEYPAD STATUS DISPLAY	28
4.1.2.3	FUNCTION OF KEYPAD KEYS IN OPERATING MODE	29
4.1.2.4	ERROR RESET WITH KEYPAD	29
4.1.2.5	KEYPAD PARAMETERISATION MODE	30
4.1.2.6	CHANGING VSD SETTINGS BY MEANS OF THE KEYPAD (general operation)	31
4.1.2.7	SAVE PARAMETER SETTINGS WITH KEYPAD	31
4.1.2.8	DISPLAY OF STATUS WORDS ON KEYPAD	31
4.1.2.9	KEYPAD SETTINGS	32
4.1.3	USB ADAPTER	33
4.2	COMMISSIONING PROCEDURE	34
4.3	GENERAL PARAMETER SETUP	34
4.3.1	DIAGNOSTIC	34
4.3.2	BASIC SETUP	34
4.3.3	MOTOR CONTROL MODES	35
5	FUNCTION & PARAMETER DESCRIPTION	37
5.1	PARAMETER / FUNCTION OVERVIEW	37
5.2	START, STOP AND ROTATING DIRECTION COMMANDS	38
5.2.1	CONTROL SELECTION	38

5.2.2	FLEXIBLE I/O CONFIGURATION	39
5.2.3	KEYPAD CONTROL.....	39
5.2.4	KEYPAD FULL CONTROL	40
5.2.5	FLEXIBLE I/O CONFIGURATION OF THE START, STOP AND ROTATING DIRECTION COMMANDS	41
5.2.6	CONTROL/RESTRICT DIRECTION OF ROTATION OF THE MOTOR.....	47
5.2.7	CHANGING THE CONTROL SOURCE DURING OPERATION	47
	5.2.7.1 EXAMPLE: CHANGE-OVER FROM TERMINAL CONTROL TO KEYPAD CONTROL	48
	5.2.7.2 EXAMPLE: CHANGE-OVER FROM TERMINAL CONTROL TO NETWORK CONTROL.....	49
5.3	GROUP 1 – DIAGNOSTICS	50
5.3.1	GENERAL DIAGNOSTIC DATA.....	50
5.3.2	OUTPUT POWER	50
5.3.3	OUTPUT ENERGY	50
5.3.4	ANALOG INPUT 1 DIAGNOSIS	51
5.3.5	ANALOG INPUT 2 DIAGNOSIS	51
5.3.6	ANALOG OUTPUT 1 VALUE.....	51
5.3.7	HTL INPUT DIAGNOSTIC.....	51
5.3.8	HEATSINK TEMPERATURE MONITORING	51
5.3.9	I/O STATUS	52
5.3.10	PROCESS CONTROLLER DIAGNOSIS	52
5.3.11	MOTOR PROTECTION I2XT	52
5.3.12	CONTROL / SETPOINT SOURCE.....	53
5.3.13	VSD STATUS.....	54
5.3.14	DEVICE OVERLOAD MONITORING (i ⁺ t)	54
5.3.15	SEQUENCER DIAGNOSTIC	55
5.3.16	ERROR CODE	55
5.3.17	TIMER / COUNTER	55
5.3.18	HISTORY BUFFER	55
5.3.19	DEVICE DATA.....	56
5.3.20	DEVICE NAME	56
5.3.21	DEVICE MODULE.....	56
5.3.22	ADDITIONAL STATUS	56
5.4	GROUP 2 – BASIC SETUP	57
5.4.1	DEFAULT CONTROL SOURCE	57
5.4.2	DEFAULT SETPOINT SOURCE	57
5.4.3	KEYPAD SETPOINTS.....	57
5.4.4	START AND STOP CONFIGURATION.....	58
	5.4.4.1 START ON POWER UP	59
	5.4.4.2 STOPPING PERFORMANCE.....	59
5.4.5	MAINS VOLTAGE.....	60
5.4.6	FREQUENCY LIMITS	60
5.4.7	ACCELERATION / DECELERATION	60
5.4.8	QUICKSTOP RAMP TIME (QSP).....	61
5.4.9	S-SHAPED RAMPS.....	62
5.4.10	OPTICAL DEVICE IDENTIFICATION	62
5.5	GROUP 3 - CONFIGURING THE MOTOR CONTROL.....	63
5.5.1	MOTOR DATA.....	63
5.5.2	MOTOR CONTROL MODE.....	64
	5.5.2.1 V/f CHARACTERISTIC CONTROL (VFC OPEN LOOP).....	64
	5.5.2.1.1 Linear V/f characteristic.....	64
	5.5.2.1.2 Square-law V/f characteristic.....	65
	5.5.2.1.3 Multipoint user-definable V/f characteristic	65
	5.5.2.1.4 Energy-saving V/f characteristic - (VFC Eco)	66
	5.5.2.2 V/f CHARACTERISTIC CONTROL (VFC CLOSED LOOP)	66
	5.5.2.3 SENSORLESS VECTOR CONTROL (SLVC)	66
	5.5.2.4 Servo control for asynchronous motors (SC-ASM).....	68
	5.5.2.5 Sensorless control for synchronous motors (SL-PSM).....	68
	5.5.2.5.1 Stall monitoring.....	69
5.5.3	OPTIMISATION OF MOTOR CONTROL.....	69
	5.5.3.1 V/f voltage boost	69
	5.5.3.2 Skip frequencies.....	70

5.5.3.3	Optimising the stalling behaviour	71
5.5.3.4	Slip compensation	71
5.5.3.5	Oscillation damping	72
5.5.4	OPTIMISATION OF THE CONTROL LOOPS	72
5.5.4.1	Options for optimized motor tuning	72
5.5.4.1.1	Tuning of the motor and the speed controller	73
5.5.4.1.2	Automatic motor identification (energized)	73
5.5.4.1.3	Automatic motor calibration (non-energized)	73
5.5.4.2	Motor equivalent circuit diagram data	74
5.5.4.3	Motor controller settings	74
5.5.4.3.1	Current controller	74
5.5.4.3.2	Field controller	74
5.5.4.3.3	Field weakening controller	75
5.5.4.3.4	I _{max} controller	75
5.5.4.3.5	Flying restart controller	75
5.5.4.3.6	SLVC controller	75
5.5.4.3.7	Slip controller	75
5.5.4.4	Speed controller	76
5.5.5	CONFIGURING THE TORQUE CONTROL	76
5.5.6	ROTATION RESTRICTION	79
5.5.7	SWITCHING FREQUENCY	79
5.5.8	MOTOR PROTECTION	79
5.5.8.1	Motor overload monitoring (I ² *t)	79
5.5.8.2	Motor temperature monitoring	81
5.5.8.3	Maximum overload current of the VSD	81
5.5.8.4	Overcurrent monitoring	81
5.5.8.5	Motor phase failure detection	82
5.5.8.6	Motor speed monitoring	82
5.5.8.7	Motor torque monitoring	82
5.5.9	ENCODER SETTINGS	83
5.5.9.1	HTL encoder	83
5.5.9.2	Encoder monitoring	84
5.5.10	Dual rating	85
5.6	GROUP 4 – I/O SETUP	86
5.6.1	FUNCTION LIST (RUN/STOP/START/JOG/REVERSE)	86
5.6.2	SETPOINT SELECTION	88
5.6.2.1	Changing the setpoint source during operation: examples	89
5.6.3	MOTOR POTENTIOMETER	94
5.6.4	USER DEFINED FAULTS	94
5.6.5	SETPOINT SOURCE SEGMENT SETPOINTS	94
5.6.6	HTL INPUT SETPOINT SOURCE	95
5.6.7	ACTIVATING DC BRAKING MANUALLY	99
5.6.8	RELEASING HOLDING BRAKE MANUALLY	100
5.6.9	FUNCTIONS FOR PARAMETER CHANGE-OVER	100
5.6.10	UPS OPERATION	102
5.6.11	DIGITAL INPUT CONFIGURATION	103
5.6.12	FREQUENCY THRESHOLD SETUP	104
5.6.13	DIGITAL OUTPUTS CONFIGURATION	104
5.6.14	ANALOG INPUT SETTINGS	106
5.6.15	ANALOG OUTPUT SETTINGS	107
5.6.16	PRESET SETPOINTS (FREQUENCY, PID, TORQUE)	109
5.7	GROUP 5 – FIELD BUS	110
5.8	GROUP 6 – PID SETUP	110
5.8.1	PID SETUP	111
5.8.2	PID FUNCTION SELECTION	112
5.8.3	PID SPEED LIMITS	112
5.8.4	PID SETPOINT LIMITS	112
5.8.5	PID ACCELERATION / DECELERATION	112
5.8.6	PID INFLUENCE	113
5.8.7	PID ALARMS	113

5.8.8	PID IDLE (SLEEP) AND RINSE FUNCTION	113
5.9	GROUP 7 – AUXILIARY FUNCTIONS	115
5.9.1	RESET PARAMETERS TO DEFAULT	115
5.9.2	SAVING/LOADING THE PARAMETER SETTINGS	115
5.9.3	KEYPAD SETUP	116
5.9.4	DELETE LOGBOOK	117
5.9.5	WIRELESS LAN (WLAN)	117
5.9.5.1	WLAN LED status displays	117
5.9.5.2	WLAN basic settings	117
5.9.5.2.1	Resetting WLAN settings to default setting	119
5.9.5.3	WLAN access point mode	119
5.9.5.3.1	Establishing a direct WLAN connection between PC and VSD	120
5.9.5.4	WLAN client mode	120
5.9.6	DC BRAKE SETUP	121
5.9.6.1	Example: Automatic DC braking when starting the motor	122
5.9.6.2	Example: Automatic DC braking when stopping the motor	123
5.9.6.3	Activating DC braking manually	125
5.9.7	BRAKE ENERGY MANAGEMENT	126
5.9.7.1	Use of a brake resistor	127
5.9.7.2	Stopping the deceleration ramp function generator	128
5.9.7.3	VSD motor brake	128
5.9.8	LOAD LOSS DETECTION	129
5.9.9	HOLDING BRAKE CONTROL	129
5.9.9.1	Holding brake control: basic setting	129
5.9.9.2	"Automatic" brake mode (automatic operation)	130
5.9.9.3	Brake holding load	130
5.9.9.4	Brake closing level	131
5.9.9.5	Manual release of the holding brake	132
5.9.10	FLYING RESTART CIRCUIT	134
5.9.11	AUTOMATIC RESTART	134
5.9.12	MAINS FAILURE CONTROL	135
5.9.12.1	Activating the mains failure control	135
5.9.12.2	Restart protection	135
5.9.12.3	Fast mains recovery	136
5.9.12.4	Commissioning the mains failure control	136
5.9.13	POSITION COUNTER	136
5.9.14	WRITE ACCESS PROTECTION	137
5.9.15	FAVORITES SETUP	137
5.9.16	PARAMETER CHANGE-OVER	138
5.10	GROUP 8 – SEQUENCER	140
5.10.1	Segment configuration	141
5.10.2	Sequence configuration	143
5.10.3	Sequencer basic settings	152
5.10.4	Sequencer control functions	153
6	TROUBLESHOOTING	157
6.1	LED STATUS DISPLAY	157
6.2	ERROR HANDLING	157
6.2.1	Error types	157
6.2.2	Error configuration	158
6.2.3	Error reset	158
6.2.4	Keypad error messages	158
6.3	ERROR HISTORY	159
6.3.1	ERROR HISTORY KEYPAD	159
6.3.2	ERROR HISTORY VLBXSW01 SOFTWARE	159
6.4	ERROR MESSAGES	160
7	UPDATE DEVICE FIRMWARE	171
8	Safe Torque Off (STO) module	173

9	MAINTENANCE	174
9.1	ROUTINE INSPECTIONS.....	174
9.2	PRODUCT SUPPORT.....	174
10	DECOMMISSIONING	174
10.1	SAFETY INSTRUCTIONS.....	174
10.2	REMOVAL AND DISPOSAL.....	174

1 SAFETY INFORMATION

1.1 INTENDED USE OF VSD

The VLB3 VSDs (Variable Speed Drive) are used for controlling low-voltage motors in industrial and commercial applications within the range of the VSD's technical specifications.

1.2 EXAMPLES OF UNINTENDED USE

- Commissioning of a VLB3 VSD in the event of visible damage or if its display shows any sign of damage.
- Commissioning of a VLB3 VSD that is not fully mounted.
- Illegal technical modifications or software modifications on a VLB3 VSD.
- Using accessories not approved for the VLB3 VSD.
- Operating a VLB3 VSD without necessary protecting covers or outside the technical specifications.
- Operating a VLB3 VSD in explosive atmosphere.

i This list shows a few examples of unintended use, it is not complete and not limited to the examples stated.

1.3 QUALIFIED PERSONNEL

Only qualified personnel according to relevant international and national standards may work on or with the VSD. The necessary skills of qualified persons are defined as follows:

- They have read and understand this operation manual.
- They are familiar with installing, mounting, commissioning, and operating the VLB3 VSD.
- They have the corresponding qualifications for their work.
- They know safe work procedures and lockout/tagout procedures to create a safe work area.
- They know and can apply all regulations for the prevention of accidents, directives, and laws applicable at the place of use.

1.4 SIGNAL WORDS AND SYMBOLS

The following symbol and signal words are used in this manual to indicate dangers and important information:

 The safety alert symbol is part of a safety message and is used to alert to potential hazards.

 **DANGER!**
DANGER indicates a hazardous situation which, if not avoided, will result in death or serious injury.

 **WARNING!**
WARNING indicates a hazardous situation which, if not avoided, could result in death or serious injury.

 **CAUTION!**
CAUTION indicates a hazardous situation which, if not avoided, could result in minor or moderate injury.

 **NOTICE!**
NOTICE indicates a situation which could lead to property damage.

i This symbol indicates an important note or helpful advice to ensure trouble-free operation.

 This symbol indicates a page reference or reference to another VLB3 manual.

1.4.1 ELEMENTS OF A SAFETY MESSAGE





- | | |
|--|---|
| <p> WARNING!
Dangerous electrical voltage
Death or severe injuries.
▶ All works on the VSD must only be carried out in the deenergised state.
▶ ...</p> | <p>← Safety alert symbol with signal word in color bar
← Type and source of danger
← Consequences of non-compliance
← Prevention measure(s)</p> |
|--|---|

1.5 WARNING LABELS ON VSD



VLB3 warning labels

Observe the following warning labels on the front side of the VSD:

WARNING LABEL	DESCRIPTION
	Dangerous electrical voltage Before working on the VSD, check whether all power connections are dead! After mains OFF, power connections X100 and X105 carry a dangerous electrical voltage for the time specified on the VSD! After switching off the mains voltage wait at least 180s before starting to work on the device.
	High leakage current Carry out fixed installation and PE connection in compliance with standard EN 61800-5-1 or EN 60204-1 !
	Hot surface Use personal protective equipment or wait until VSD has cooled down!
WARNING LABEL	DESCRIPTION
	Electrostatic sensitive devices Before working on the VSD, the staff must ensure to be free of electrostatic charge!

1.6 BASIC SAFETY MEASURES

WARNING!

Workplace hazards

Possible death or severe personal injury.

- Observe all specifications of the corresponding documentation supplied. This is the precondition for safe and trouble-free commissioning and operation of the VSD and for obtaining the product features specified.
- Observe the specific safety instructions in this operation manual.
- Equip the VSD/drive system with additional monitoring and protection devices if required by national safety regulations.
- Commissioning of the VSD and the related drive system (i.e. starting of the operation as directed) is prohibited until it is proven that the machine complies with the regulations of the EC Directive 2006/42/EC (Machinery Directive); the standard EN 60204 must be observed.



WARNING!

Dangerous electrical voltage

An electrical shock can cause death or severe personal injury.

- Apply lockout/tagout procedures whenever possible.
- Connect/disconnect all pluggable VSD connections only in deenergised condition!
- Only remove the VSD from the installation in completely deenergised state.

NOTICE!

Incorrect VSD installation

Disregarding the following instructions may lead to VSD damage and damage to material assets:

- The VSD must be installed and cooled according to the instructions given in the “VLB3 Mounting and switch-on instructions”. The ambient air must not exceed pollution degree 2 according to EN 61800-5-1.
- Ensure proper handling and avoid excessive mechanical stress. Do not bend any VSD components and do not change any insulation distances during transport or handling.

NOTICE!

Incomplete or faulty VSD parameterization

Disregarding the following advices may lead to VSD damage and damage to material assets:

- Always check if the procedural notes and circuit details described in this document can be adapted to the particular application.

1.7 ELECTROMAGNETIC INFLUENCES

The VLB3 VSDs can be installed in drive systems of category C2 according to EN 61800-3. These devices can cause radio interferences in residential areas. In this case, special measures can be necessary.

NOTICE!

Possible electromagnetic interference of drive and control system

Sporadic malfunctions can cause unsafe operation conditions.

- Commissioning of the VSD and the related drive system (i.e. starting of the operation as directed) is only allowed when there is compliance with the EMC Directive (2004/108/EC).
- The VSD must be installed in a housing (e.g. control cabinet) to meet the limit values for radio interferences valid at the site of installation.

1.8 RESIDUAL HAZARDS

Consider the following residual hazards in the risk assessment of the application.

 **WARNING!**

Unexpected drive motion

Possible personal injury or property damage.

If there is a short circuit of two power transistors in the VSD, a residual movement of up to $180^\circ/\text{number of pole pairs}$ can occur at the connected motor! (For 4-pole motor: residual movement max. $180^\circ/2 = 90^\circ$).

 **WARNING!**

Dangerous residual voltage – long discharge time!

An electrical shock can cause death or severe personal injury.

– After the VSD or the drive system has been disconnected from the supply voltage, all live components and power terminals must not be touched immediately because capacitors in the VSD can still be charged.

– Observe the waiting time on the VSD label.

 **WARNING!**

High leakage current

VLB3 VSDs may cause a DC current in the PE conductor.

Possible personal injury due to inappropriate or insufficient protective measures.

– If a residual current device (RCD) is used for protection against direct or indirect contact for an VSD with three-phase supply, only a residual current device (RCD) of type B is permissible on the supply side of the VSD.

– If the VSD has a single-phase supply, a residual current device (RCD) of type A is also permissible.

– Apart from using a residual current device (RCD), other protective measures can be taken as well, e.g. electrical isolation by double or reinforced insulation or isolation from the supply system by means of a transformer.

2 PRODUCT DESCRIPTION

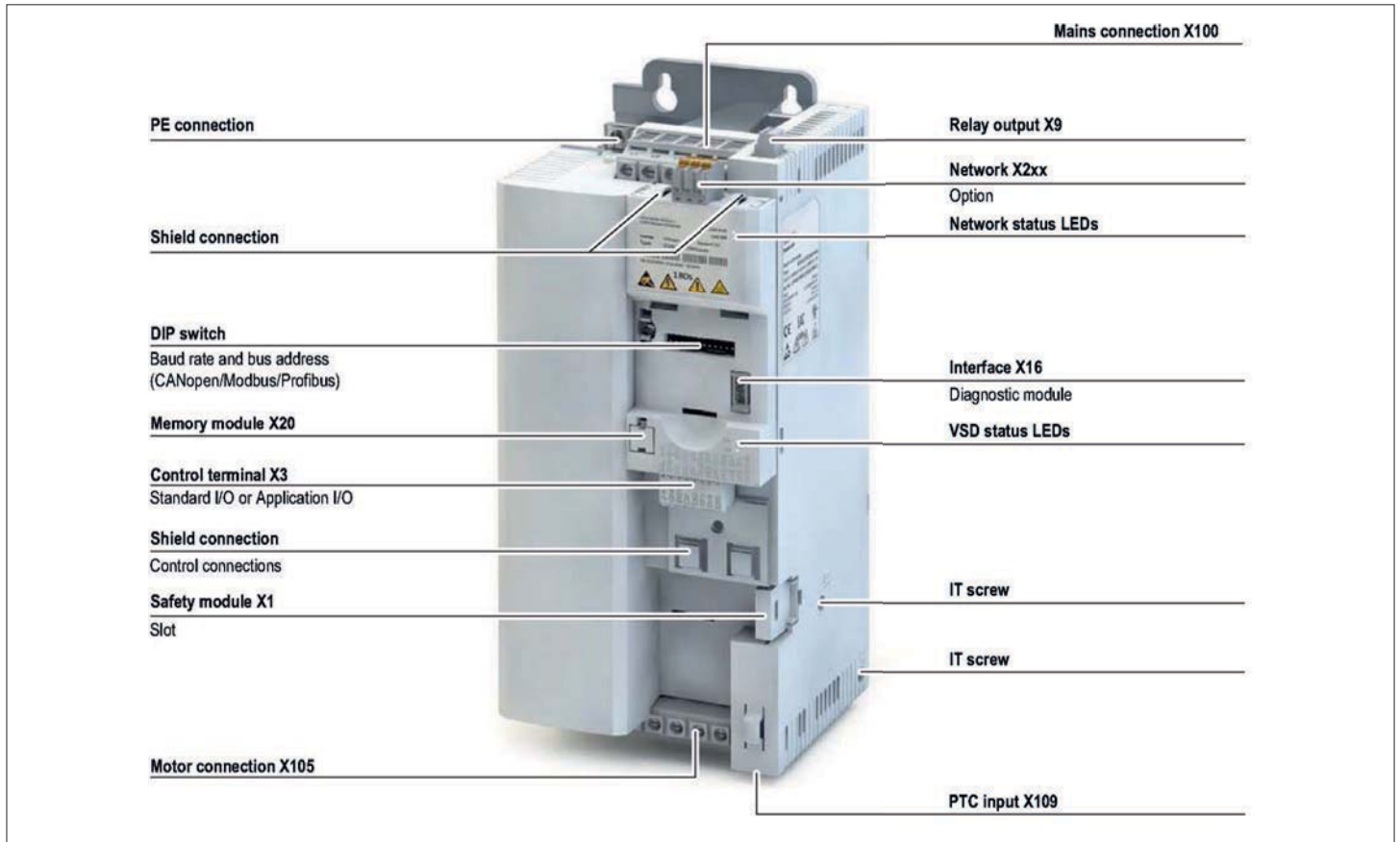

2.1 CONNECTION TO THE IT SYSTEM

Internal components have earth potential if the IT screws are not removed.
Consequence: the monitoring functions of the IT system respond.

Before connection to an IT system be also-lutely sure to remove the IT screws.



3 MOUNTING

3.1 DIMENSIONS AND MECHANICAL INSTALLATION

3.1.1 DIMENSION 0,37KW

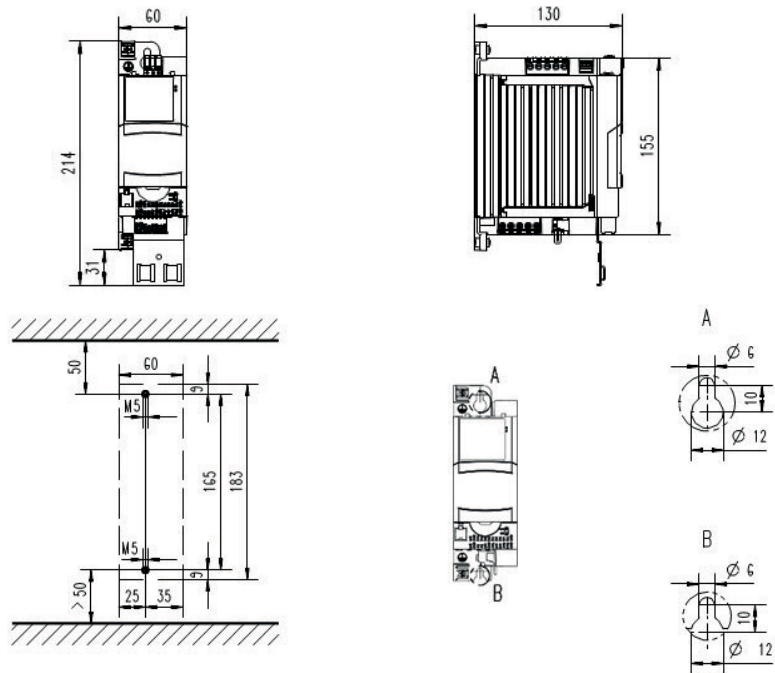

3.1.2 DIMENSION 0,75KW

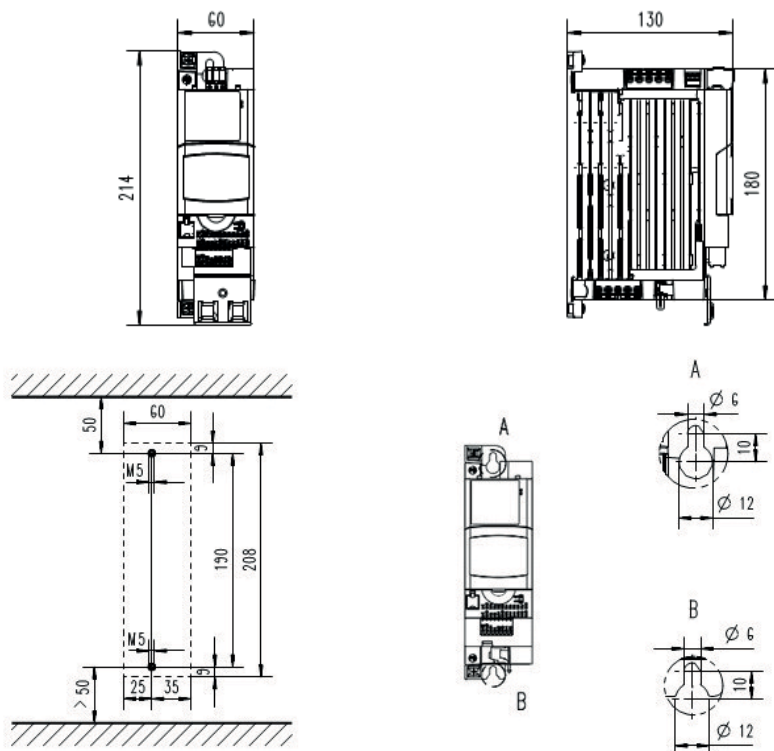

All dimensions in mm

3.1.3 DIMENSION 1,5KW..2,2KW

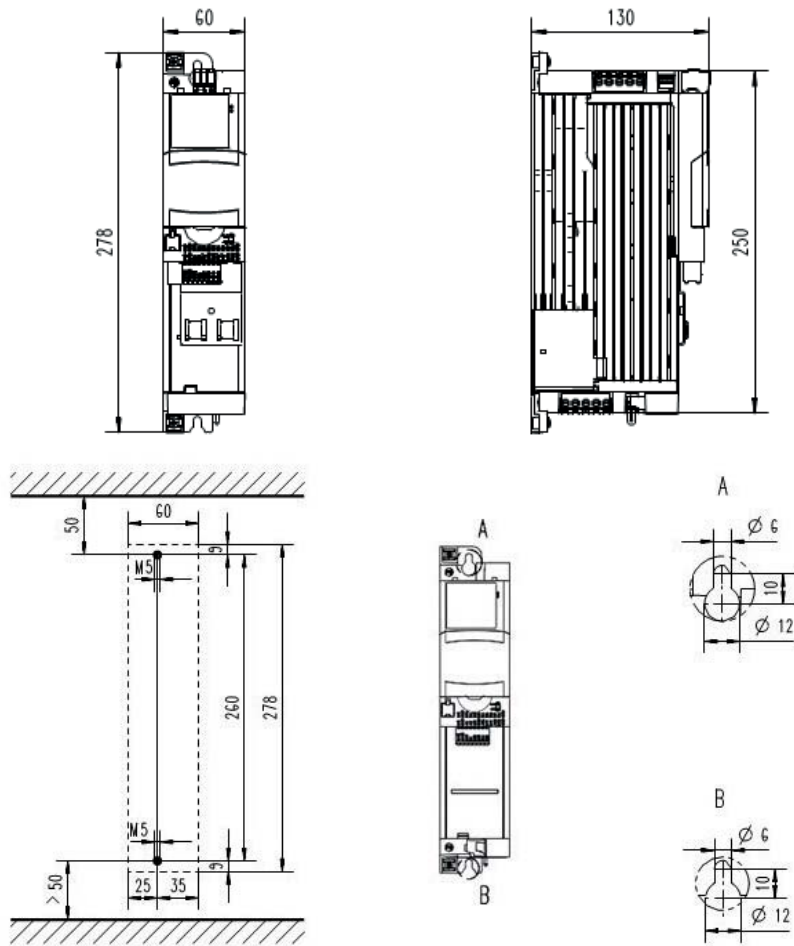

3.1.4 DIMENSIONS 4KW..5,5KW

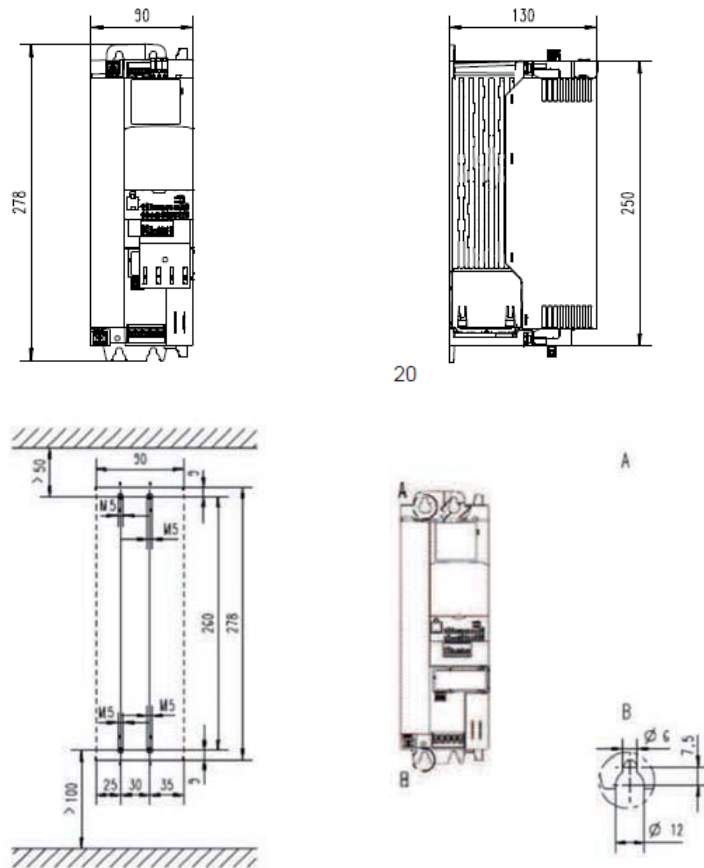

All dimensions in mm

3.1.5 DIMENSIONS 7,5KW ... 11KW

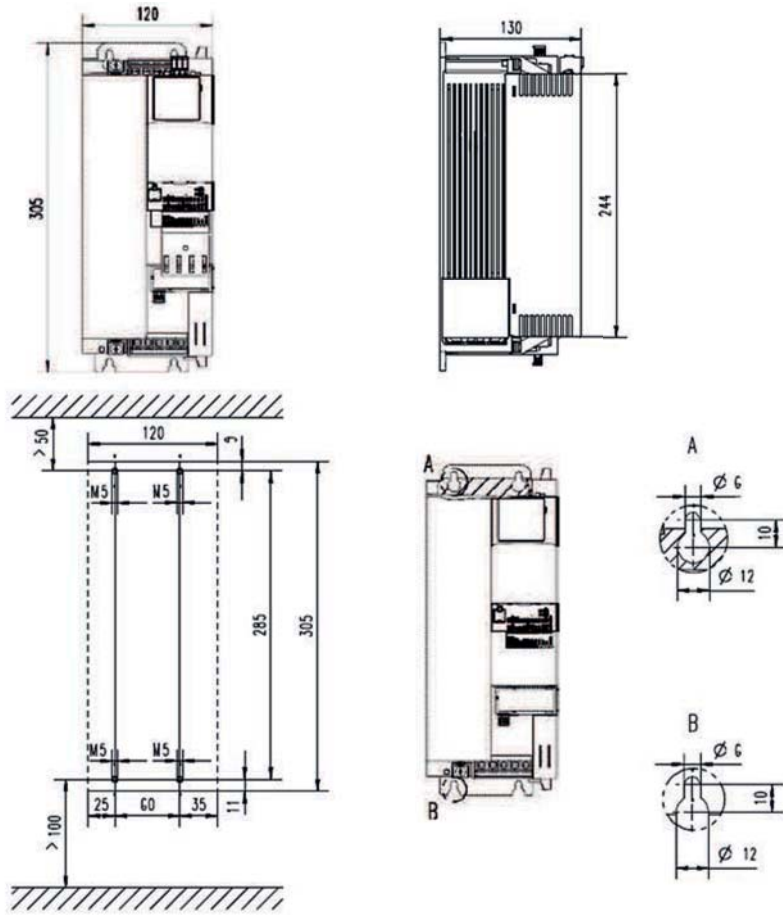

3.1.6 DIMENSIONS 15KW ... 22KW

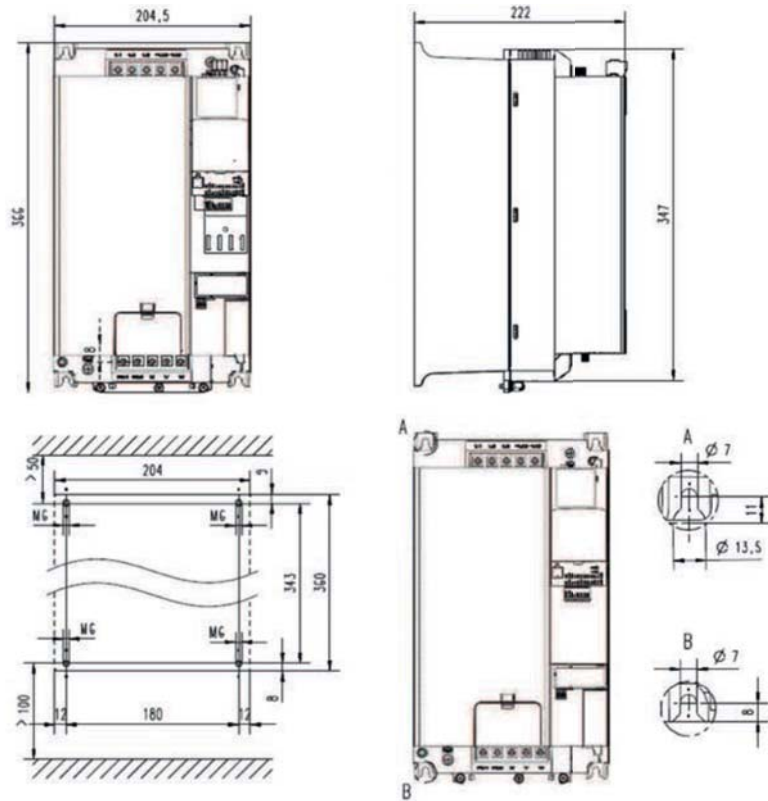

All dimensions in mm

3.1.7 DIMENSIONS 30KW...45KW

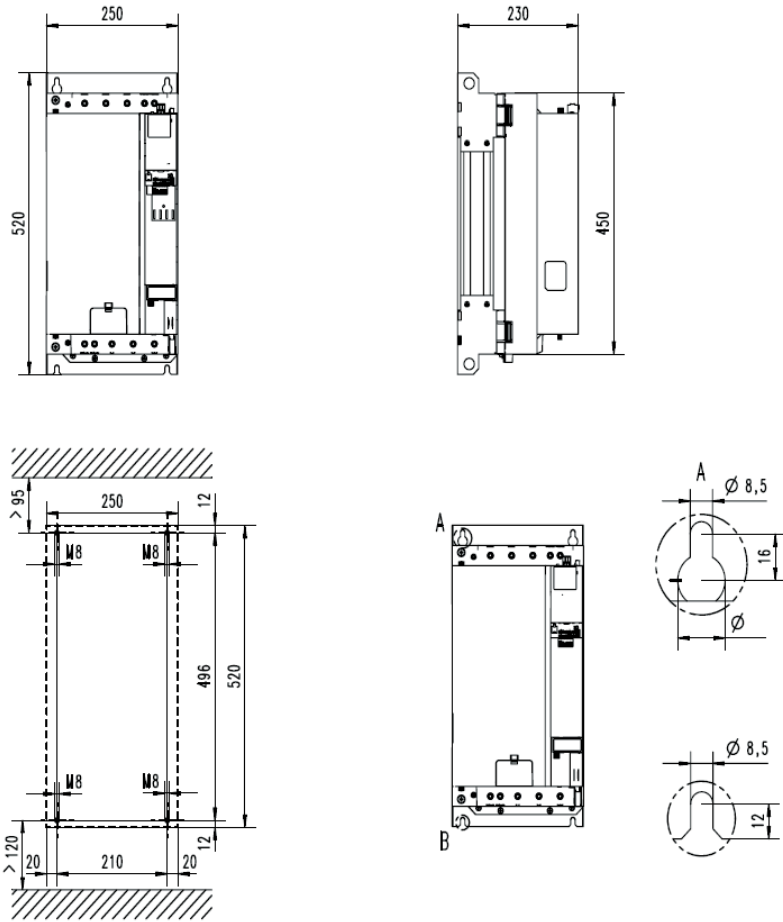

3.1.8 DIMENSIONS 55KW...75KW

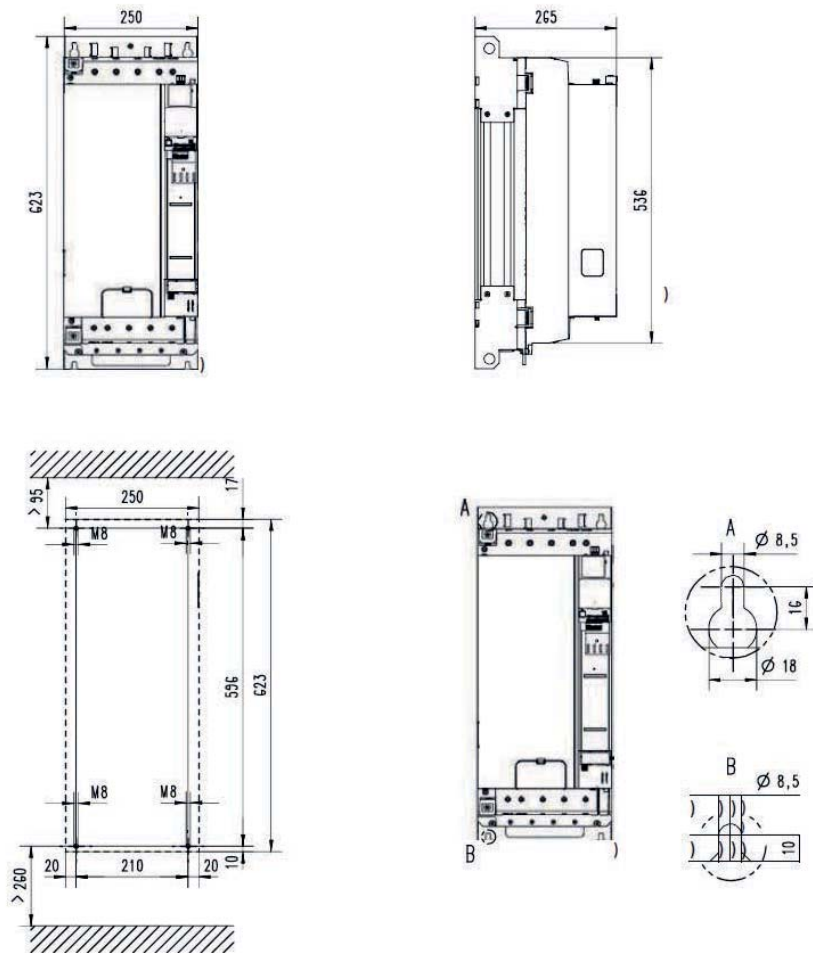

All dimensions in mm

3.1.9 DIMENSIONS 90KW...110KW

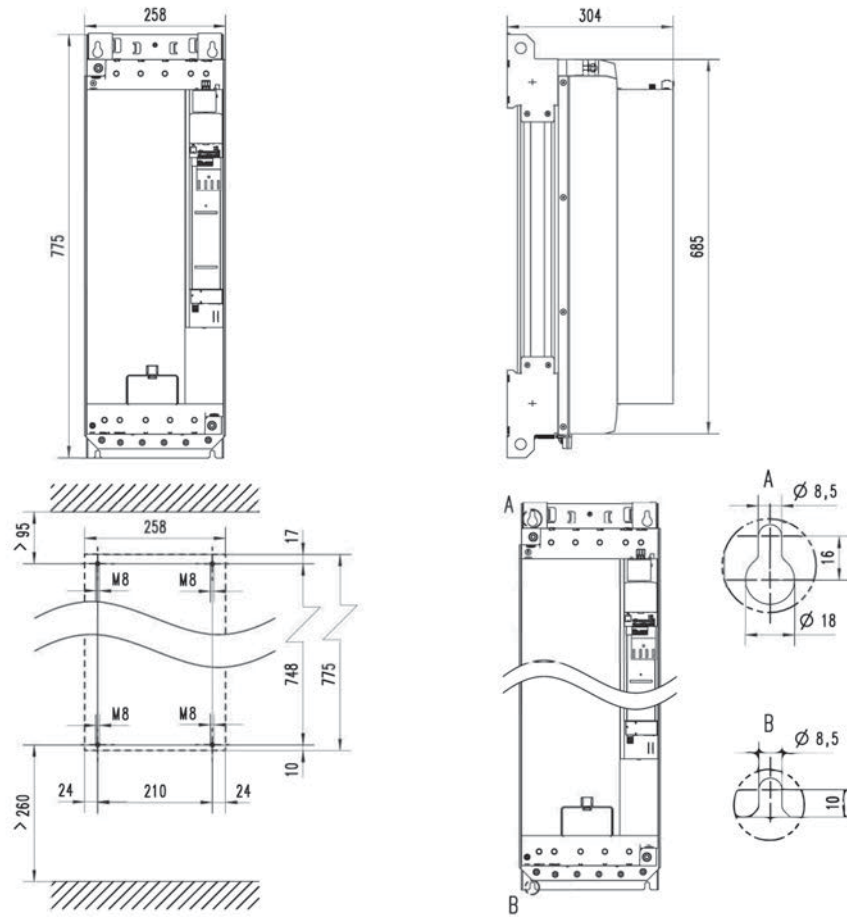

All dimensions in mm

3.2 ELECTRICAL INSTALLATION

3.2.1 CONNECTION TO THE 400 V SYSTEM

3.2.1.1 WIRING DIAGRAM

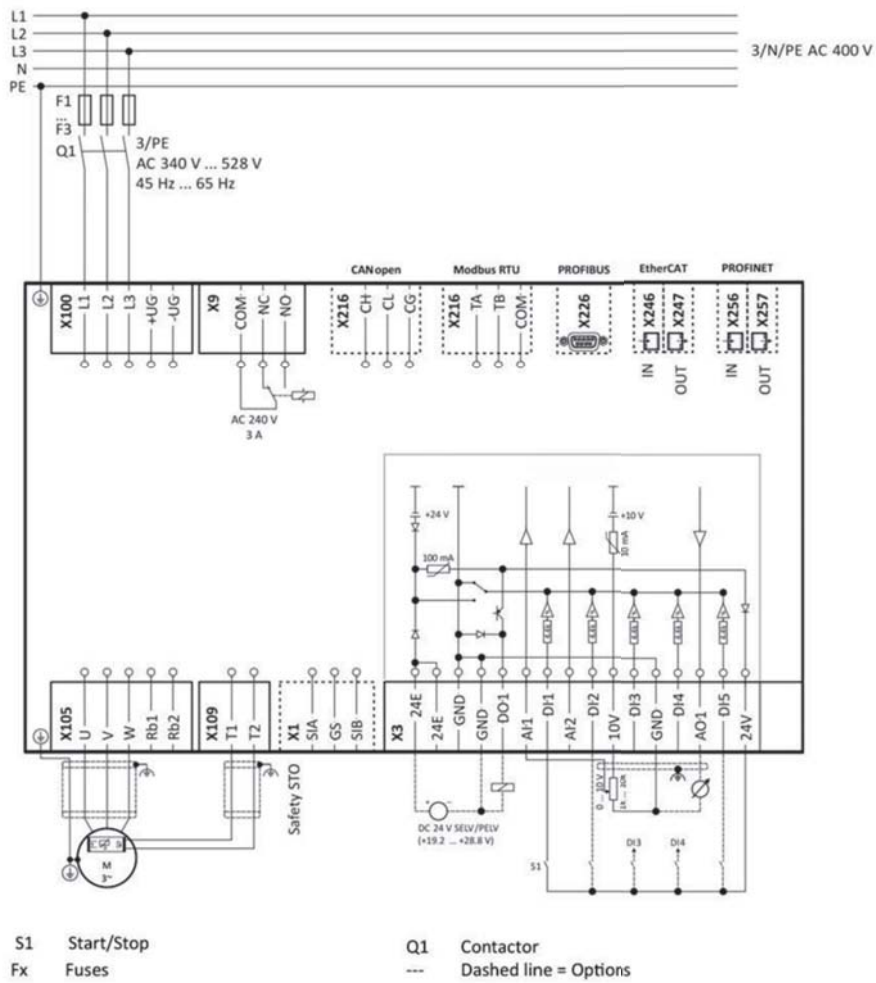

3.2.1.2 FUSES AND CABLE CROSS-SECTIONS

Rated power	kW	0.4	0.75
Cable installation in compliance with		EN 60204-1	
Laying system		B2	
Operation		Without mains choke	
Fuse			
Characteristics		gG/gL or gRL	
Max. rated current	A	10	
Circuit breaker			
Characteristics		B	
Max. rated current	A	10	
Operation		With mains choke	
Fuse			
Characteristics		gG/gL or gRL	
Max. rated current	A	10	
Circuit breaker			
Characteristics		B	
Max. rated current	A	10	
Earth-leakage circuit breaker			
3-phase mains connection		≥ 30 mA, type B	
Mains connection			
Connection		X100	
Connection type		Screw terminal	
Min. cable cross-section	mm ²	1	
Max. cable cross-section	mm ²	2.5	
Stripping length	mm	8	
Tightening torque	Nm	0.5	
Required tool		0.5 x 3.0	
Motor connection			
Connection		X105	
Connection type		Screw terminal	
Min. cable cross-section	mm ²	1	
Max. cable cross-section	mm ²	2.5	
Stripping length	mm	8	
Tightening torque	Nm	0.5	
Required tool		0.5 x 3.0	
PE connection			
Connection		PE	
Connection type		PE screw	
Min. cable cross-section	mm ²	1	
Max. cable cross-section	mm ²	6	
Stripping length	mm	10	
Tightening torque	Nm	2	
Required tool		Torx 20	

Rated power	kW	1.5	2.2	4
Cable installation in compliance with		EN 60204-1		
Laying system		B2		
Operation		Without mains choke		
Fuse				
Characteristics		gG/gL or gRL		
Max. rated current	A	16	16	25
Circuit breaker				
Characteristics		B		
Max. rated current	A	16	16	25
Operation		With mains choke		
Fuse				
Characteristics		gG/gL or gRL		
Max. rated current	A	16	16	25
Circuit breaker				
Characteristics		B		
Max. rated current	A	16	16	25
Earth-leakage circuit breaker				
3-phase mains connection		≥ 30 mA, type B		≥ 300 mA, type B
Mains connection				
Connection		X100		
Connection type		Screw terminal		Screw terminal
Min. cable cross-section	mm ²	1	1.5	
Max. cable cross-section	mm ²	2.5	6	
Stripping length	mm	8	9	
Tightening torque	Nm	0.5		
Required tool		0.5 x 3.0		0.6 x 3.5
Motor connection				
Connection		X105		
Connection type		Screw terminal		Screw terminal
Min. cable cross-section	mm ²	1	1.5	
Max. cable cross-section	mm ²	2.5	6	
Stripping length	mm	8	9	
Tightening torque	Nm	0.5		
Required tool		0.5 x 3.0		0.6 x 3.5
PE connection				
Connection		PE		
Connection type		PE screw		
Min. cable cross-section	mm ²	1	1.5	
Max. cable cross-section	mm ²	6	6	
Stripping length	mm	10	10	
Tightening torque	Nm	2	2	
Required tool		Torx 20		

Rated power	kW	5.5	7.5	11	15
Cable installation in compliance with		EN 60204-1			
Laying system		B2			
Operation		Without mains choke			
Fuse		gG/gL or gRL			
Characteristics					
Max. rated current	A	25	32	32	63
Circuit breaker		B			
Characteristics					
Max. rated current	A	25	32	32	63
Operation		With mains choke			
Fuse		gG/gL or gRL			
Characteristics					
Max. rated current	A	25	32	32	63
Circuit breaker		B			
Characteristics					
Max. rated current	A	25	32	32	63
Earth-leakage circuit breaker		≥ 300 mA, type B			
3-phase mains connection					
Mains connection		X100			
Connection		Screw terminal			
Connection type					
Min. cable cross-section	mm ²	1.5			
Max. cable cross-section	mm ²	6	16	35	
Stripping length	mm	9	11	18	
Tightening torque	Nm	0.5	1.2	3.8	
Required tool		0.6 x 3.5	0.8 x 4.0	0.8 x 5.5	
Motor connection		X105			
Connection		Screw terminal			
Connection type					
Min. cable cross-section	mm ²	1.5			
Max. cable cross-section	mm ²	6	16	35	
Stripping length	mm	9	11	18	
Tightening torque	Nm	0.5	1.2	3.8	
Required tool		0.6 x 3.5	0.8 x 4.0	0.8 x 5.5	
PE connection		PE			
Connection		PE screw			
Connection type					
Min. cable cross-section	mm ²	1.5	1.5	1.5	
Max. cable cross-section	mm ²	6	16	25	
Stripping length	mm	10	11	16	
Tightening torque	Nm	2	3.4	4	
Required tool		Torx 20	PZ2		

Rated power	kW	18.5	22	30	37
Cable installation in compliance with		EN 60204-1			
Laying system		B2		C	
Operation		Without mains choke			
Fuse					
Characteristics		gG/gL or gRL		-	
Max. rated current	A	63	-	-	-
Circuit breaker					
Characteristics		B		-	
Max. rated current	A	63	-	-	-
Operation		With mains choke			
Fuse					
Characteristics		gG/gL or gRL			
Max. rated current	A	63	63	80	100
Circuit breaker					
Characteristics		B			
Max. rated current	A	63	63	80	100
Earth-leakage circuit breaker					
3-phase mains connection		≥ 300 mA, type B			
Mains connection					
Connection		X100			
Connection type		Screw terminal			
Min. cable cross-section	mm ²	1.5		10	
Max. cable cross-section	mm ²	35		50	
Stripping length	mm	18		19	
Tightening torque	Nm	3.8		4	
Required tool		0.8 x 5.5		Allen key 4.0	
Motor connection					
Connection		X105			
Connection type		Screw terminal			
Min. cable cross-section	mm ²	1.5		10	
Max. cable cross-section	mm ²	35		50	
Stripping length	mm	18		19	
Tightening torque	Nm	3.8		4	
Required tool		0.8 x 5.5		Allen key 4.0	
PE connection					
Connection		PE			
Connection type		PE screw			
Min. cable cross-section	mm ²	1.5			
Max. cable cross-section	mm ²	25			
Stripping length	mm	16			
Tightening torque	Nm	4			
Required tool		PZ2			

Rated power	kW	45	55	75
Cable installation in compliance with		EN 60204-1		
Laying system		C	F	
Operation				
Fuse				
Characteristics		-		
Max. rated current	A	-	-	-
Circuit breaker				
Characteristics		-		
Max. rated current	A	-	-	-
Operation		With mains choke		
Fuse				
Characteristics		gG/gL or gRL	gR	
Max. rated current	A	125	160	
Circuit breaker				
Characteristics		B	-	
Max. rated current	A	125	-	-
Earth-leakage circuit breaker				
3-phase mains connection		≥ 300 mA, type B		
Mains connection				
Connection		X100		
Connection type		Screw terminal		
Min. cable cross-section	mm ²	10	25	
Max. cable cross-section	mm ²	50	95	
Stripping length	mm	19	22	
Tightening torque	Nm	4	10	
Required tool		Allen key 4.0	Allen key 6.0	
Motor connection				
Connection		X105		
Connection type		Screw terminal		
Min. cable cross-section	mm ²	10	25	
Max. cable cross-section	mm ²	50	95	
Stripping length	mm	19	22	
Tightening torque	Nm	4	10	
Required tool		Allen key 4.0	Allen key 6.0	
PE connection				
Connection		PE		
Connection type		PE screw		
Min. cable cross-section	mm ²	1.5	4	
Max. cable cross-section	mm ²	25	25	
Stripping length	mm	16	16	
Tightening torque	Nm	4	4	
Required tool		PZ2	PZ2	

Rated power	kW	90	110
Cable installation in compliance with		EN 60204-1	
Laying system		F	
Operation			
Fuse			
Characteristics		—	
Max. rated current	A	—	
Circuit breaker			
Characteristics		—	
Max. rated current	A	—	
Operation		With mains choke	
Fuse			
Characteristics		gR	
Max. rated current	A	300	
Circuit breaker			
Characteristics		—	
Max. rated current	A	—	
Earth-leakage circuit breaker			
3-phase mains connection		≥ 300 mA, type B	
Mains connection			
Connection		X100	
Connection type		Screw terminal	
Min. cable cross-section	mm ²	—	
Max. cable cross-section	mm ²	150	
Stripping length	mm	28	
Tightening torque	Nm	18	
Required tool		Allen key 8.0	
Motor connection			
Connection		X105	
Connection type		Screw terminal	
Min. cable cross-section	mm ²	—	
Max. cable cross-section	mm ²	150	
Stripping length	mm	28	
Tightening torque	Nm	18	
Required tool		Allen key 8.0	
PE connection			
Connection		PE	
Connection type		PE bolt	
Min. cable cross-section	mm ²	—	
Max. cable cross-section	mm ²	150	
Stripping length	mm	—	
Tightening torque	Nm	10	
Required tool		Key 13	

3.2.1.3 DC-BUS voltage operative range

Rated mains voltage	DC-Bus voltage range
400...480VAC	480...750VDC

3.2.1.4 Data of control connections

DIGITAL INPUTS

Switching type		PNP, NPN	Parameterisable
PNP switching level			
LOW	V	< +5	IEC 61131-2, type 1
HIGH	V	> +15	
NPN switching level			
LOW	V	> +15	
HIGH	V	< +5	
Input resistance	k Ω	4.6	
Cycle time	ms	1	can be changed by software filtering
Electric strength of external volt- age	V	± 30	

Frequency input			
Connection		X3/DI3, X3/DI4	
Frequency range	kHz	0 ... 100	

Encoder input			
Type		Incremental HTL encoder	
Two-track connection		X3/DI3 X3/DI4	Track A Track B
Frequency range	kHz	0...100	

DIGITAL OUTPUTS

Switching level			
LOW	V	< +5	IEC 61131-2, type 1
HIGH	V	> +15	
Max. output current	mA	100	Total current for DO1 and 24V
Cycle time	ms	1	
Short-circuit strength		Unlimited period	
Electric strength of external voltage	V	± 30	
Polarity reversal protection		Integrated freewheeling diode for switchingthe inductive load	
Overload behaviour		Reduced voltage or periodic switch-off/on	
Reset or switch-on behaviour		Output is switched off	LOW

ANALOG INPUTS

Cycle time	ms	1	
Resolution of A/D converter	Bit	12	
Operation as voltage input			
Connection designation		X3/AI1, X3/AI2	
Input voltage DC	V	-10 ... 10	
Input resistance	k Ω	70	
Accuracy	mV	± 50	Typical
Input voltage in case of open circuit	V	- 0.2...0.2	Display "0"
Electric strength of external voltage	V	± 24	
Operation as current input			
Connection designation		X3/AI1, X3/AI2	
Input current	mA	0...20 4...20	open-circuit monitored
Accuracy	mA	± 0.1	Typical
Input current in case of open circuit	mA	< 0.1	Display "0"
Input resistance	Ω	< 250	
Electric strength of external voltage	V	± 24	

ANALOG OUTPUTS

Short-circuit strength		Unlimited period	
Electric strength of external voltage	V	+ 24V	
Operation as voltage output			
Resolution of D/A converter	Bit	12	
Output voltage DC	V	0 ... 10	
Max. output current	mA	5	
Max. capacitive load	µF	1	
Accuracy	mV	± 100	Typical
Operation as current output			
Output current	mA	0 ... 20 4 ... 20	open-circuit monitored
Accuracy	mA	± 0.3	Typical

10-V OUTPUT

Use		Primarily for the supply of a potentiometer (1 ... 10 kΩ)	
Output voltage DC			
Typical	V	10	
Accuracy	mV	± 100	
Max. output current	mA	10	
Max. capacitive load	µF	1	
Short-circuit strength		Unlimited period	
Electric strength of external voltage	V	+ 24	

24-V INPUT

Use		Input for mains-independent DC supply of the control electronics (incl. communication)	
Input voltage DC			
Typical	V	24	IEC 61131-2
Range	V	19.2 ... 28.8	
Input power			
Typical	W	3.6	
Max.	W	6	Depending on the use and state of inputs and outputs.
Input current			
Typical	A	0.150	
Max.	A	1.0	When switching on for 50 ms
Capacity to be charged	µF	440	
Polarity reversal protection		When polarity is reversed: No function and no destruction	
Suppression of voltage pulses		Suppressor diode 30 V, bidirectional	
Power supply unit		SELV/PELV	Externally to create a mains-independent DC supply
Max. current	A	8.0	While looping-through

24-V OUTPUT

Use		Primarily for the supply of digital inputs	
Output voltage DC			
Typical	V	24	
Range	V	16 ... 28	
Max. output current	mA	100	Total current for DO... and 24V
Short-circuit strength		Unlimited period	
Electric strength of external voltage	V	+ 30	
Excess current release		Automatically resettable	

Relay output

i Relay is not suitable for direct switching of an electromechanical holding brake! Use a corresponding suppressor circuit in case of an inductive or capacitive load!

Connection		Terminal X9: COM	Centre contact (common)	
		Terminal X9: NC	Normally-closed contact	
		Terminal X9: NO	Normally-open contact	
Minimum DC contact load				
Voltage	V	10	A correct switching of the relay contacts needs both values to be exceeded simultaneously.	
Current	mA	10		
Switching voltage/switching current				
Maximum	AC 240 V	A	3	According to UL: General Purpose
	DC 24 V	A	2	According to UL: Resistive
	DC 240 V	A	0.16	

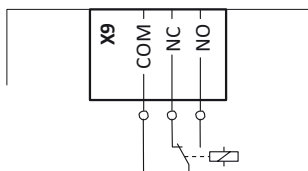

PTC input

i In the Lovato Electric setting, motor temperature monitoring is activated! In the delivery status, there is a wire jumper between the terminals T1 and T2. Before connecting a thermal sensor, remove the wire jumper.

Use	Connection of PTC or thermal contact
Connection	Terminal X109: T1 Terminal X109: T2
Sensor types	PTC single sensor (DIN 44081) PTC triple sensor (DIN 44082) Thermal contact

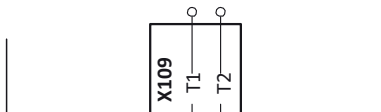

Terminal description		Relay output	PTC input	Control terminals
Connection		X9	X109	X3
Connection type		Screw terminal	Screw terminal	Spring terminal
Min. cable cross-section	mm ²	0.5	0.5	0.5
Max. cable cross-section	mm ²	1.5	1.5	1.5
Stripping length	mm	6	6	9
Tightening torque	Nm	0.2	0.2	—
Required tool		0.4x2.5	0.4x2.5	0.4x2.5

3.2.2 CONNECTION OF THE SAFETY MODULE VLBXSM

3.2.2.1 Important notes



Improper installation of the safety engineering system can cause an uncontrolled starting action of the drives.

Possible consequences: Death or severe injuries

- Safety engineering systems may only be installed and commissioned by qualified and skilled personnel.
- All control components (switches, relays, PLC, ...) and the control cabinet must comply with the requirements of the EN ISO 13849-1 and the EN ISO 13849-2.
- Switches, relays with a least IP54 enclosure.
- Control cabinet with at least IP54 enclosure.
- It is essential to use insulated wire end ferrules for wiring.
- All safety relevant cables outside the control cabinet must be protected, e.g. by means of a cable duct.
- Ensure that no short circuits can occur according to the specifications of the EN ISO 13849-2.
- All further requirements and measures can be obtained from the EN ISO 13849-1 and the EN ISO 13849-2.
- If an external force acts upon the drive axes, additional brakes are required. Please observe that hanging loads are subject to the force of gravity!
- The user has to ensure that the VSD will only be used in its intended application within the specified environmental conditions. This is the only way to comply with the declared safety-related characteristics.



DANGER! With the "Safe torque off" (STO) function, no "emergency stop" in terms of EN 60204-1 can be executed without additional measures. There is no isolation between the motor and VSD, no service switch or maintenance switch!

Possible consequence: death or severe injuries.

- "Emergency stop" requires electrical isolation, e.g. by a central mains contactor.



Automatic restart if the request of the safety function is deactivated.

Possible consequence: death or severe injuries.

- You must provide external measures according to EN ISO 13849-1 which ensure that the drive only restarts after a confirmation.



NOTICE!

Overvoltage

Destruction of the safety component.

- The maximum voltage (maximum rated) at the safety inputs is 32VDC. The user must make provisions to avoid that this voltage is exceeded.

3.2.2.2 Connection plan

Passive sensors	Active sensors													
<div style="margin-top: 10px;"> <table border="1" style="border-collapse: collapse; text-align: center;"> <tr> <th>SIA</th> <th>SIB</th> <th>VFD status</th> </tr> <tr> <td>0</td> <td>0</td> <td rowspan="2">STO active</td> </tr> <tr> <td>0</td> <td>1</td> </tr> <tr> <td>1</td> <td>0</td> <td rowspan="2">VFD enabled</td> </tr> <tr> <td>1</td> <td>1</td> </tr> </table> </div> <p style="font-size: small; margin-top: 10px;">S1 safety switching device S2 passive sensor</p>	SIA	SIB	VFD status	0	0	STO active	0	1	1	0	VFD enabled	1	1	<p style="font-size: small; margin-top: 10px;">S1 active sensor - example lightgrid</p>
SIA	SIB	VFD status												
0	0	STO active												
0	1													
1	0	VFD enabled												
1	1													

3.2.2.3 Terminal Data

Terminal description	Unit	Safety STO
Connection		x1
Connection type		Screw terminal
Min. cable cross-section	mm ²	0.5
Max. cable cross-section	mm ²	1.5
Stripping length	mm	6
Tightening torque	Nm	0.2
Required screwdriver		0.4x2.5

X1	Specification	Unit	min.	typ.	max.	
SIA, SIB	LOW signal	V	-3	0	+5	
	HIGH signal	V	+15	+24	+30	
	Running time	ms		3		
	Input current SIA	mA		10	14	
	Input current SIB	mA		7	12	
	Input peak current	mA		100		
	Tolerated test pulse	ms				1
	Switch-off time	ms			50	
	Permissible distance of the test pulses	ms	10			
GS	Reference potential for SIA and SIB					

4 COMMISSIONING

DANGER!

Hazards during parameter change

A parameter change gets immediately active. This can result in an unexpected reaction of the motor shaft.

- Do Parameter change, if possible, only if the VSD is inhibited.

WARNING!

Hazards during VSD installation and commissioning



Possible death or severe personal injury.

- Only authorized and qualified persons are allowed to install and commission the VSD.
- Keep the manual at hand.
- Proper lockout/ tagout procedures must be applied to prevent inadvertently starting of motor or making alive of equipment.
- The motor shall be uncoupled from load and free to rotate before performing tests. Verify that the equipment is ready to be operated and that all safety circuits have been checked and are operational.

4.1 OPERATING INTERFACES

Three set-up methods with special tools and software are available for commissioning the VLB3.

4.1.1 OVERVIEW

	<p>Keypad VLBX C01</p> <ul style="list-style-type: none"> – Change parameter – Diagnosis – Local control <p>If it's only a matter of setting a few key parameters such as acceleration and deceleration time, this can be done quickly on the keypad.</p>
	<p>USB adapter VLBX C02</p> <ul style="list-style-type: none"> – Change parameter (advanced) – Out of the box commissioning (parameter change without main power) – Diagnosis – Parameter management <p>If functions such as the motor potentiometer or sequence control for a positioning application need to be set, it's best to use VLBXSW01 software.</p>
	<p>WLAN VLBX C03</p> <ul style="list-style-type: none"> – Change parameter (advanced) – Diagnosis – Parameter management <p>Use VLBXSW01 software and laptop wireless connection.</p>

4.1.2 KEYPAD

The keypad is an easy means for the local operation, parameterisation, and diagnostics of the VSD.

- Type code: VLBX C01



- The keypad is simply connected to the diagnostic interface on the front of the VSD.
- The keypad can also be connected and removed during operation.

4.1.2.1 KEYPAD OPERATING MODE

After switching on the VSD, the keypad plugged in is in "Operating mode" after a short initialisation phase.

4.1.2.2 KEYPAD STATUS DISPLAY

In the operating mode, the keypad displays information on the status of the VSD.

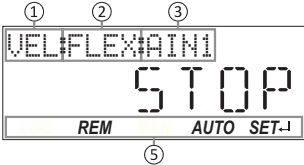
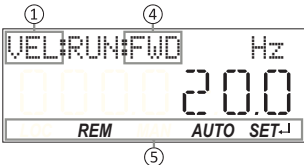
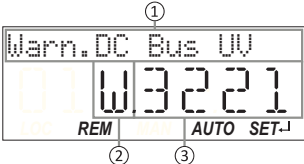
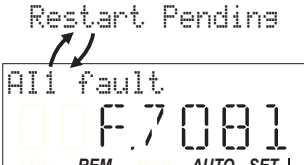
Keypad display	Display	Meaning																																											
<p>If the VSD is inhibited, the keypad shows "STOP":</p>  <p>If the VSD is enabled, the keypad shows the output frequency of the VSD:</p>  <ul style="list-style-type: none"> - In the process controller mode, instead of the output frequency, the process controller setpoint is displayed. - The display can be configured in P703.00. - The language for the keypad display is preset to "English". The language can be changed in P705.00. 	<p>① Active control mode:</p> <table border="1"> <tr><td>VEL</td><td>Speed mode</td></tr> <tr><td>PID</td><td>Process controller mode</td></tr> <tr><td>TRQ</td><td>Torque mode</td></tr> <tr><td>JOG</td><td>Manual mode</td></tr> </table> <p>② Active control source:</p> <table border="1"> <tr><td>FLEX</td><td>Flexible I/O configuration</td></tr> <tr><td>KPD</td><td>Keypad</td></tr> <tr><td>KPDF</td><td>Keypad (complete control via keypad including setpoint selection)</td></tr> <tr><td>NET</td><td>Network</td></tr> </table> <p>③ Active setpoint source:</p> <table border="1"> <tr><td>AINx</td><td>Analog input x</td></tr> <tr><td>KPD</td><td>Keypad</td></tr> <tr><td>NET</td><td>Network</td></tr> <tr><td>FREQ</td><td>Digital frequency</td></tr> <tr><td>PRx</td><td>Preset setpoint x</td></tr> <tr><td>SEGx</td><td>Segment x</td></tr> <tr><td>MOP</td><td>Motor potentiometer</td></tr> </table> <p>④ Current direction of rotation:</p> <table border="1"> <tr><td>FWD</td><td>Motor is rotating forwards</td></tr> <tr><td>REV</td><td>Motor is rotating backwards</td></tr> </table> <p>⑤ Lower status line:</p> <table border="1"> <tr><td>LOC</td><td>Local keypad control active.</td></tr> <tr><td>REM</td><td>Remote control via terminals, network, etc. active.</td></tr> <tr><td>MAN</td><td>Manual setpoint selection via keypad active.</td></tr> <tr><td>AUTO</td><td>Automatic setpoint selection via terminals, network, etc. active.</td></tr> <tr><td>SET</td><td>Blinking if one parameter setting has been changed but has not been saved in the memory module with mains failure protection. Save settings: Press keypad enter key longer than 3 s.</td></tr> </table>	VEL	Speed mode	PID	Process controller mode	TRQ	Torque mode	JOG	Manual mode	FLEX	Flexible I/O configuration	KPD	Keypad	KPDF	Keypad (complete control via keypad including setpoint selection)	NET	Network	AINx	Analog input x	KPD	Keypad	NET	Network	FREQ	Digital frequency	PRx	Preset setpoint x	SEGx	Segment x	MOP	Motor potentiometer	FWD	Motor is rotating forwards	REV	Motor is rotating backwards	LOC	Local keypad control active.	REM	Remote control via terminals, network, etc. active.	MAN	Manual setpoint selection via keypad active.	AUTO	Automatic setpoint selection via terminals, network, etc. active.	SET	Blinking if one parameter setting has been changed but has not been saved in the memory module with mains failure protection. Save settings: Press keypad enter key longer than 3 s.
VEL	Speed mode																																												
PID	Process controller mode																																												
TRQ	Torque mode																																												
JOG	Manual mode																																												
FLEX	Flexible I/O configuration																																												
KPD	Keypad																																												
KPDF	Keypad (complete control via keypad including setpoint selection)																																												
NET	Network																																												
AINx	Analog input x																																												
KPD	Keypad																																												
NET	Network																																												
FREQ	Digital frequency																																												
PRx	Preset setpoint x																																												
SEGx	Segment x																																												
MOP	Motor potentiometer																																												
FWD	Motor is rotating forwards																																												
REV	Motor is rotating backwards																																												
LOC	Local keypad control active.																																												
REM	Remote control via terminals, network, etc. active.																																												
MAN	Manual setpoint selection via keypad active.																																												
AUTO	Automatic setpoint selection via terminals, network, etc. active.																																												
SET	Blinking if one parameter setting has been changed but has not been saved in the memory module with mains failure protection. Save settings: Press keypad enter key longer than 3 s.																																												
<p>If an error is pending, the keypad shows the following information:</p>  <ul style="list-style-type: none"> - Faults (F) and trouble (T) are displayed continuously. - Warnings (W) are only displayed every 2 seconds for a short time. 	<p>① Error text</p> <p>② Error type:</p> <table border="1"> <tr><td>F</td><td>Fault</td></tr> <tr><td>T</td><td>Trouble</td></tr> <tr><td>W</td><td>Warning</td></tr> </table> <p>③ Error code (hexadecimal) - For more info see the Error code table.</p>	F	Fault	T	Trouble	W	Warning																																						
F	Fault																																												
T	Trouble																																												
W	Warning																																												
	<p>After a disturbance, a restart is possible if the error condition is not active anymore. The keypad shows this by the "Restart Pending" note. The note is displayed in a 1-second interval alternating with the error text.</p>																																												

4.1.2.3 FUNCTION OF KEYPAD KEYS IN OPERATING MODE

In the operating mode, the keypad can be used for local control and for manual setpoint selection.

Function of keypad keys in operating mode			
Key	Actuation	Condition	Action
	Shortly	Local keypad control active. Display "LOC"	Run motor.
	Shortly	Remote control active Display "REM" Display "KSTOP"	Deactivate keypad triggered stop. The motor remains at standstill. Display changes from "KSTOP" to "STOP".
	Shortly	Operating mode	Change to parameterisation mode.
	More than 3 s	None (anytime possible)	Save parameter settings in the user memory of the memory module.
	Shortly	During operation	Scroll through information in the above status line.
	Shortly	Manual setpoint selection via keypad active. Display "MAN"	Change frequency setpoint.
	Shortly	Operating mode	Activate full keypad control (from version 4.1). Display "ON?" → Confirm with ↵ Control and setpoint selection can now only be carried out via keypad. Renewed clicking: Exit full keypad control. Display "OFF?" → Confirm with ↵
	Shortly	Local keypad control active. Display "LOC"	Reversal of rotation direction (from version 4.1). Display "REV?" → Confirm with ↵

EXAMPLE: CHANGE SETPOINT

If the setpoints are selected manually via keypad, the frequency setpoint can be changed in the operating mode via the arrow keys (even while the motor is running):

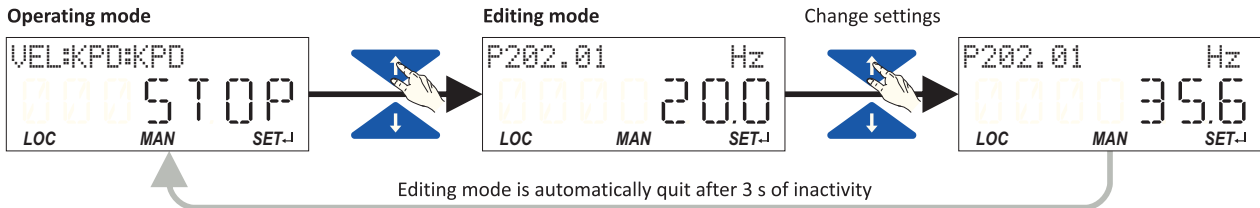

4.1.2.4 ERROR RESET WITH KEYPAD

Use the keypad key to reset a resettable error if the error condition no longer exists and no blocking time is active.

– The "Error code table" gives the blocking time (if available) for each error.

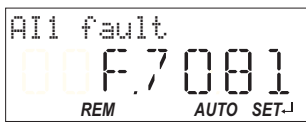

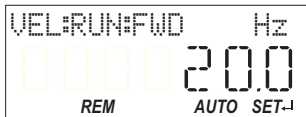

1. Press keypad key.
The error is reset. The motor remains stopped via keypad (display "KSTOP").
2. In order to cancel the stop via keypad again: Press keypad key.



4.1.2.5 KEYPAD PARAMETERISATION MODE

In the parameterisation mode of the keypad you can have actual values of the VSD displayed for purposes of diagnostics and change settings of the VSD.

Use the  to change from operating mode to the parameterisation mode.

- If a write access protection is active for the VSD, the keypad automatically displays a log-in when changing to the parameterisation mode. You can either skip the log-in and thus keep the access protection active or remove it temporarily by entering a valid PIN.
- Use the  to return to the operating mode.

PARAMETER GROUPS









In order to provide for quick access, all parameters of the VFD are divided into different groups according to their function.

- Group 0 contains the configurable "Favorites". In the default setting these are the most common parameters for the solution of typical applications.
- Based on the hundreds digit of the display code (Pxxx) you can quickly see in which group the parameter is to be found on the keypad:

Parameter	Group/name	Description
P1xx	Group 1 - Diagnostics	Diagnostic/display parameters for displaying device-internal process factors, current actual values, and status messages.
P2xx	Group 2 - Basic setting	Setting of the mains voltage, selection of the control and setpoint source, starting and stopping performance, frequency limits and ramp times.
P3xx	Group 3 - Motor control	Configuration of the motor and motor control
P4xx	Group 4 - I/O setting	Function assignment and configuration of the inputs and outputs
P5xx	Group 5 - Network setting	Configuration of the network (if available)
P6xx	Group 6 - Process controller	Configuration of the process controller
P7xx	Group 7 - Additional functions	Parameterisable additional functions
P8xx	Group 8 - Sequencer	The "sequencer" function serves to define a programmed sequence of speed setpoints, PID setpoints or torque setpoints for the motor control. Switching to the next setpoint can be executed in a time-based or event-based manner.

FUNCTION OF THE KEYPAD KEYS IN THE PARAMETERISATION MODE

In the parameterisation mode, the arrow keys serve to select and change parameters.

Function of the keypad keys in the parameterisation mode			
Key	Actuation	Condition	Action
	Shortly	Local keypad control active. Display "LOC"	Run motor.
		Remote control active Display "REM" Display "KSTOP"	Deactivate keypad triggered stop. The motor remains at standstill. Display changes from "KSTOP" to "STOP".
	Shortly	No Jog operation	Stop motor. Display "KSTOP"
	Shortly	Parameterisation mode	Navigate to one level below. Group level → Parameter level → [SUB parameter level] → Editing mode
		Editing mode	Exit editing mode and accept new setting.
	More than 3 s	None (anytime possible)	Save parameter settings in the user memory of the memory module.
	Shortly	Parameterisation mode	Navigate to one level above. [SUB parameter level] → Parameter level → Group level → Operating mode
		Editing mode	Abort: Exit editing mode without accepting new setting.
 	Shortly	Group level/Parameter level	Navigate: Select group/parameter.
		Editing mode	Change parameter setting.
			Without function
			Without function

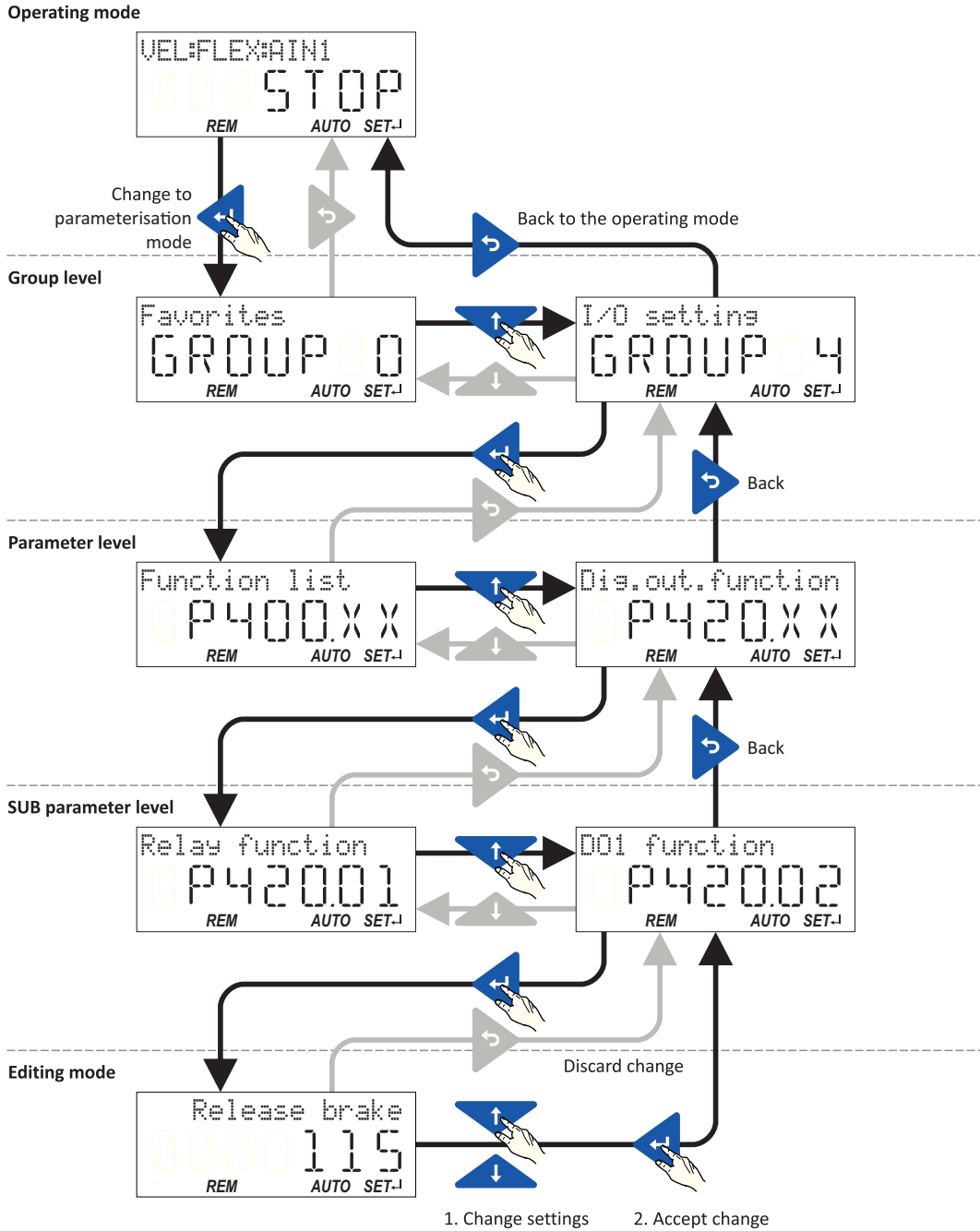

4.1.2.7 SAVE PARAMETER SETTINGS WITH KEYPAD

If one parameter setting has been changed with the keypad but has not been saved in the memory module with mains failure protection, the SET display is blinking. In order to save parameter settings in the user memory of the memory module, press the keypad enter key longer than 3 s.



4.1.2.8 DISPLAY OF STATUS WORDS ON KEYPAD

Some diagnostics parameters contain bit-coded status words. Each single bit has a certain meaning.

Display of 16-bit status words on the keypad

Display of 16-bit status words on the keypad

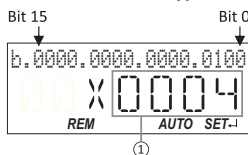

① Hexadecimal value

Display of 32-bit status words on the keypad

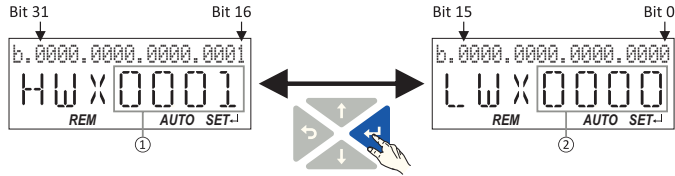

- ① Hexadecimal value High word (HW)
- ② Hexadecimal value Low word (LW)

4.1.2.9 KEYPAD SETTINGS

For the keypad various settings can be made, which are described in detail in the following subchapters.

Select language

Parameter	Name / setting range / [default setting]	Info	
P705:00	Keypad language selection (KP language)	Language selection for the keypad display.	
	0		No language selected
	1		English
	2		German

Change setpoint increment

Parameter	Name / setting range / [default setting]	Info
P701:00	Keypad setpoint increment (KP setp. incr.) 1 ... [1] ... 100	Adaptation of the increment for keypad setpoints when a keypad arrow key is pressed once. The value set serves as a multiplier for the preset increments. Setting 1 corresponds to the following increments: <ul style="list-style-type: none"> - 0.1 Hz for frequency setpoint P202:01. - 0.01 PUnit for process controller setpoint P202:02. - 0.1 % for torque setpoint P202:03. Notes: <ul style="list-style-type: none"> - With a setting > 1, the option of repeatedly changing the setpoint by pressing the key for a longer time is deactivated. - The setting only has an impact on the keypad setpoints. Example: with the setting "5", the keypad frequency setpoint is increased/decreased by 0.5 Hz every time the key is pressed.

Configure status display

During operation, the keypad displays the output frequency of the VL3, or with an active PID control it shows the process controller setpoint. Alternatively, an optional diagnostic parameter can be displayed during operation.

Parameter	Name / setting range / [default setting]	Info
P703:00	Keypad status display (KP status displ.) 0x00000000 ... [0x00000000] ... 0xFFFFFFFF	0 = normal display depending on the operating mode <ul style="list-style-type: none"> - In case of an active frequency control, the keypad displays the output frequency of the drive. - In case of active PID control, the keypad displays the current Process controller setpoint in [P-Unit]. As an alternative, an optional diagnostic parameter can be set here, which is to be shown on the keypad during operation. <ul style="list-style-type: none"> - Format: 0xiiii00 (iiii = hexadecimal index, ss = hexadecimal subindex) - The lowest byte is always 0x00. - The keypad can be used to select the desired diagnostics parameter from a list.
P702:00	Speed display scaling (Scal.speed fact.) 0.00 ... [0.00] ... 650.00	Factor for the scaling of the speed display in 0x400D (P101.00). <ul style="list-style-type: none"> - With the setting "0.00", no scaling takes place. - Example: with the "16.50" and the actual frequency = 50 Hz, 0x400D (P101.00) shows the speed "825 units".

Configure R/F and CTRL keys Keypad rotation setup

Use the keypad to reverse the rotation direction at local keypad control.

- After the key has been pressed, the reversal of rotation direction must be confirmed with the key. (The key serves to cancel the action.)

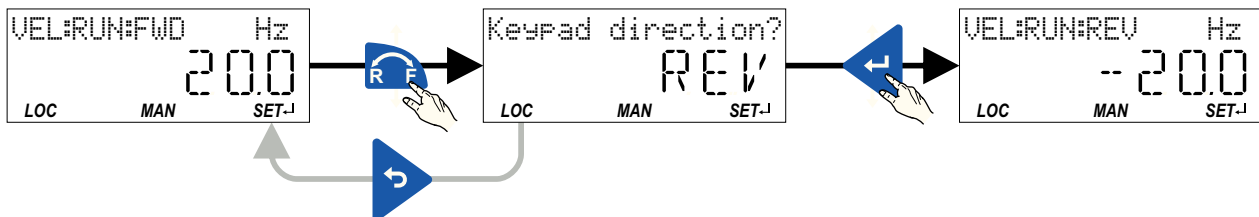

The keypad key

- directly changes the keypad rotation setup in P708:02.
- has no function in case of a bipolar setpoint selection (e. g. ±10 V). In this case, the direction of rotation is determined by the sign of the setpoint.
- has no function if the rotation limitation "Only clockwise (CW) [0]" is set in P304:00.
- has no function in the operating mode P301:00 = "MS: Torque mode [-1]".
- has no function if the PID control is activated.
- can be deactivated in P708:01.

Keypad Full Control

The "Keypad Full Control" control mode can be activated with the keypad key "CTRL". Both the control and the setpoint selection are then made via the keypad. This special control mode can be, for instance, used during the commissioning phase if external control and setpoint sources are not ready to use yet.

The keypad key CTRL

- directly changes the setting in P708:03.
- can be deactivated in P708:01.

Parameter

Parameter	Name / setting range / [default setting]	Info
P708:01	Keypad setup: CTRL & F/R key setup (Keypad setup: CTRL&F/R keys) – From version 4.1	Disable/enable CTRL and F/R key of the keypad.
	0 CTRL & F/R Disable	
	1 CTRL & F/R Enable	
	2 CTRL Enable F/R Disable	
	3 CTRL Disable F/R Enable	
P708:02	Keypad setup: Select rotational direction (Keypad setup: Select rot.dir.) – From version 4.1	Instructed direction of rotation if local keypad control is active. – If the local keypad control is active, this setting can be directly changed via the keypad key  if the key in P708:01 has not been disabled. – When the remote control is changed over to local keypad control and vice versa, this parameter is set to "Forward [0]".
	0 Forward	
	1 Reverse	
P708:03	Keypad setup: Keypad Full Control (Keypad setup: Keypad Full Ctrl) – From version 4.1	Activate/deactivate full keypad control. – This setting can be changed directly via the keypad key CTRL if the key in P708:01 has not been disabled. – When the control mode is changed over, the motor is stopped and the "Forward" direction of rotation is set.
	0 Off	
	1 On	
	2 Manual mode	

4.1.3 USB ADAPTER

Required materials

- USB adapter (Type code: VLBX C02)
- VLBXSW01 software
- PC or laptop with free USB port
- USB 2.0 cable (A plug on micro-B plug)



i The VLBXSW01 software is available for free - see download area on the LOVATO Electric web (www.lovatoelectric.com)

Procedure

1. Download and install the VLBXSW01 software.
2. Connect USB adapter to VSD.
3. Connect USB adapter to laptop with USB cable.

i No external voltage or mains voltage is required to program the VSD.

4. Run VLBXSW01 software.
5. Select "USB with module Lovato VLBXC02" for communication. Then click on "Insert" button.
6. Program VSD:

Setting	Guided setting windows
Diagnosis	Actual status of VSD / IO / Errors / Controller
Parameter list	Access to all parameters
Trend	Record data trends from VSD values

➔ For more information see documentation of the VLBXSW01 software.

7. Click on the following icon to save the parameters to the VSDs nonvolatile memory:



4.1.4 WI-FI ADAPTER

Required materials

- Wi-Fi adapter (type code: VLBX C03).
- VLBXSW01 software (version from 1.12)
- PC or laptop with Wi-Fi connection.



Note. The Wi-Fi adapter is compatible with VLB3 with firmware revision ≥ 4.1 .

i The VLBXSW01 software is available for free - see download area on the LOVATO Electric web (www.lovatoelectric.com)

Procedure

1. Download and install the VLBXSW01 software.
2. Connect Wi-Fi adapter to VSD.
3. Connect the PC to the WLAN generated by the Wi-Fi adapter.
4. Run VLBXSW01 software.
5. Select "Wi-Fi module VLBXC03" for communication. Then click on "Insert" button.
6. Program VLB3 (are valid the same considerations given for USB adapter).

For details about Wi-Fi module VLBXC03 see chapter "5.9.4 WIRELESS LAN (WLAN)".

4.2 COMMISSIONING PROCEDURE

Use the following table as a reminder that guides you through the commissioning procedure.

Step	Action	Information
1	Initial checks <ul style="list-style-type: none"> – Check delivery for completeness. – Check the nameplate information to ensure that you have the correct type of VSD for your motor/application. – Check for delivery damages. Don't continue if your VSD seems to be damaged! 	
2	Module assembly <ul style="list-style-type: none"> – Assembly your Safety Unit (Option) 	→ See VLB3 installation manual, instruction I472
3	Mechanical installation <ul style="list-style-type: none"> – Install the VSD according to the instruction. 	
4	Electrical installation <ul style="list-style-type: none"> – If you install the VSD to an IT network, remove the IT-screws. – Install the control wiring. – Install motor and supply wiring in accordance to the EMC requirements. 	
5	Functional test (if needed) Perform a uncoupled functional test for basic test	
6	General parameter setup The VLB3 has linked the most common parameters to the favorites menu. With these parameters most common basic application can be solved.	→ 4.4 General parameter setup (favorites)
7	Parameter setup (auxiliary functions) The VLB3 contains additional functions which can be used for more complex applications.	→ 5 Function & parameter description
8	Testrun & tuning <ul style="list-style-type: none"> – Run the motor and check the performance of your application. – Adjust the corresponding parameter to tune your application. 	→ 5 Function & parameter description
9	Diagnose & troubleshooting Status LED and error messages are available for troubleshooting.	→ 6 Troubleshooting

4.3 GENERAL PARAMETER SETUP

This chapter leads you through the favorites menu and gives you basic hints.

For detailed information about the parameters and additional functions, see chapter "5 Function & parameter description"

4.3.1 DIAGNOSTIC

Parameter	Type	Description	Default setting	Unit
P100:0	Diagnostics	Output frequency	Actual value	Hz
P104:0	Diagnostics	Output motor current	Actual value	%
P106:0	Diagnostics	Motor voltage	Actual value	VAC
P150:0	Diagnostics	Error code	Actual value	–

Further diagnostic parameters are available in Group 1 – Diagnostics.

4.3.2 BASIC SETUP

1. Select the default control location (terminal – flexible or keypad).
2. Select the default frequency setpoint.
3. Select the required start and stop method for your application.
4. Check if correct mains voltage is set for your network.
5. Set the motor frequency range (see illustration below).
6. Set the motor acceleration/ deceleration time (see illustration below).

Parameter	Type	Description	Default setting	Unit
P200:0	Basic Setup	Control source	0: Flexible	–
P201:1	Basic Setup	Frequency setpoint.source	2: Analog input 1	–
P203:1	Basic Setup	Start method	0: Normal	–
P203:3	Basic Setup	Stop method	1: Standard Ramp	–
P208:1	Basic Setup	Mains voltage	230/400/480 Typecode dependent	VAC
P210:0	Basic Setup	Minimum frequency	0.0	Hz
P211:0	Basic Setup	Maximum frequency	50.0 / 60.0 Typecode dependent	Hz
P220:0	Basic Setup	Acceleration time 1	5.0	sec
P221:0	Basic Setup	Deceleration time 1	5.0	sec

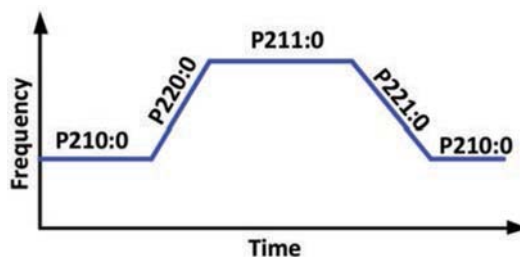

Motor settings

4.3.3 MOTOR CONTROL MODES

Most applications like fans, pumps, and conveyors are possible in V/f (Voltage/frequency) mode. If the application requires more dynamic and speed assurance then the SLVC (Sensor less Vector Control) mode can be used.

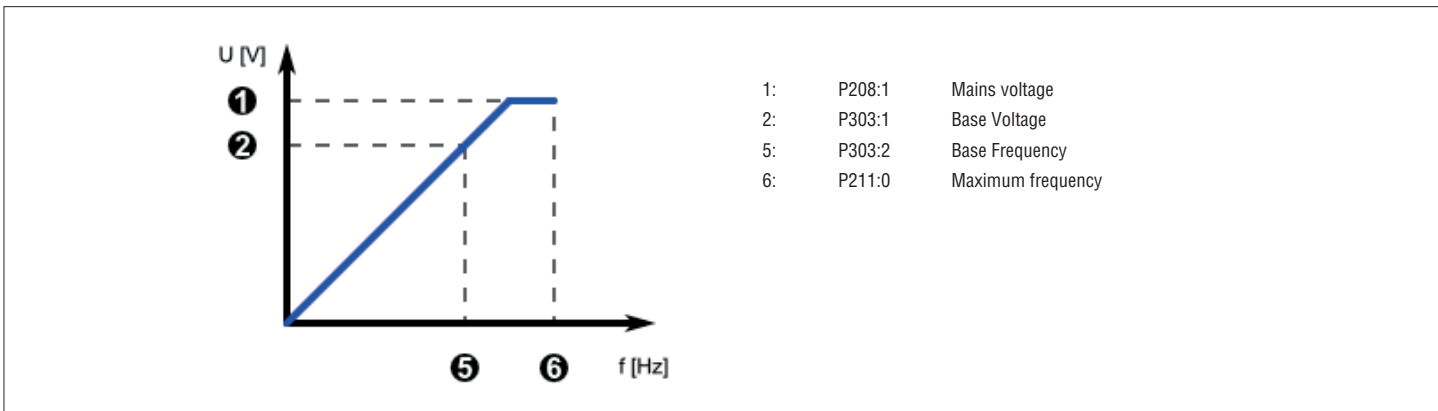

V/F mode

For V/f mode set the following parameters:

Example: 400V/50Hz Motor
Base Voltage = 400V
Base Frequency = 50 Hz

Parameter	Type	Description	Default setting	Unit
P300:0	Motor Control	Motor control mode	6: VFC open loop	–
P302:0	Motor Control	V/f shape	0: Linear	–
P303:1	Motor Control	Base Voltage	230/400/480 Typecode dependent	VAC
P303:2	Motor Control	Base Frequency	50.0 / 60.0 Typecode dependent	Hz

➔ For SLVC mode refer to chapter “Motor control mode”.

MOTOR ROTATION RESTRICTION

Set this parameter if your application requires that the motor is running only in one direction:

Parameter	Type	Description	Default setting	Unit
P304:0	Motor Control	Limitation of rotation	1: Both directions	–

Tuning parameters

For most applications the default tuning parameters can be used:

Parameter	Type	Description	Default setting	Unit
P305:0	Motor control	Switching frequency	21: 8kHz var/opt/4kHz min.	kHz
P308:1	Motor control	Max load for 60s	150	%
P316:1	Motor control	Fixed V/f boost	0.4%...2.5% Typecode dependent	%
P324:0	Motor control	Max current	200.0	%

➔ If the performance is insufficient during operation, see chapter “Motor Control setup” for tuning the parameters above.

Control selection

The VLB3 can be controlled from various locations and in different ways.

Parameter	Type	Description	Default setting	Unit
P200:0	Basic Setup	Control source	0: Flexible	–

Basic functionalities:

- VSD enable
Enables the VSD. Signal must have the state TRUE (by Input or setting) to be able to start the motor.
- Run/Stop
Enables the running of the motor. Can be used as single signal or in combination with the signals Start Forward / Start Reverse. Signal must have the state TRUE (by Input or setting) to be able to start the motor.
- Start Forward / Start Reverse
Used to start the motor (Positive edge triggered). Stop is down with the Run/Stop signal.
- Run Forward / Run Reverse
Used to run and stop the motor (Maintained signals)
- Rotation inversion
Inverts the speed setpoint
- Fault Reset
For a successful reset of a fault it is necessary to correct the condition that caused the fault first. Afterwards there are different possibilities to reset the fault:
- Quick Stop (QSP) works as “pause” / “zero-speed” function. (The QSP ramp time can be set in P225:0)

i In Flexible Control mode (P200:0) either VSD enable (P400:1) or Run/Stop (P400:2) must be assigned to I/O to ensure that the drive can always be stopped! (Exception: VSD is controlled from network, Network enable (P400:37) is HIGH)

➤ See chapter "5.2 Flexible I/O configuration" on page 32 for control application examples.
See chapter "5.6.1 Function list (Run/Stop/Start/Jog/Reverse)" on page 76 for detailed information.

Parameter	Type	Description	Default setting	Unit
P400:1	I/O Setup	VSD enable	1: TRUE	–
P400:2	I/O Setup	Run/Stop	11: Digital input 1	–
P400:3	I/O Setup	Quick Stop [QSP]	0: Not connected	–
P400:4	I/O Setup	Reset fault	12: Digital input 2	–
P400:5	I/O Setup	DC brake	0: Not connected	–
P400:6	I/O Setup	Start forward (CW)	0: Not connected	–
P400:7	I/O Setup	Start reverse (CCW)	0: Not connected	–
P400:8	I/O Setup	Run forward (CW)	0: Not connected	–
P400:9	I/O Setup	Run reverse (CCW)	0: Not connected	–
P400:13	I/O Setup	Invert rotation	13: Digital input 3	–
P400:18	I/O Setup	Preset selection bit0	14: Digital input 4	–
P400:19	I/O Setup	Preset selection bit1	15: Digital input 5	–
P400:20	I/O Setup	Preset selection bit2	0: Not connected	–

OUTPUT SELECTION

The digital output and relay can be used as feedback signal for your control system.

Parameter	Type	Description	Default setting	Unit
P420:1	I/O Setup	Relay function	51: Ready for operation	–
P420:2	I/O Setup	DO1 function	115: Release holding brake	–

ANALOG INPUT 1 FOR SPEED SETPOINT

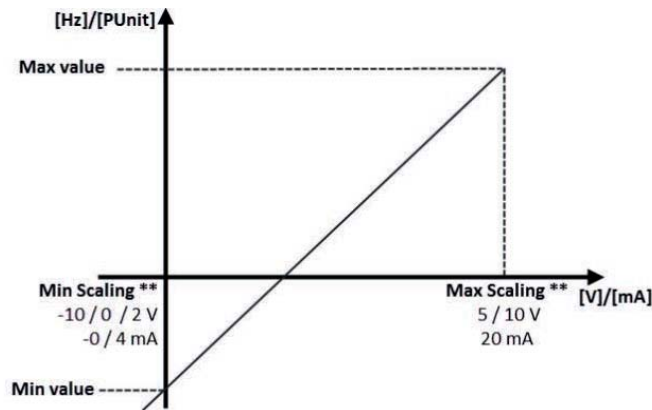

** Availability of scaling depending on type of control unit.

Speed setpoint

If you have defined the AI1 as your speed setpoint define the correct input scaling.

Parameter	Type	Description	Default setting	Unit
P430:1	I/O Setup	AI1 input range	0: 0...10VDC	–
P430:2	I/O Setup	AI1 frequency @ min	0.0	Hz
P430:3	I/O Setup	AI1 frequency @ max	50.0/60.0 *Typecode dependent	Hz

ANALOG OUTPUT 1

Analog output can be used as a feedback for your control system. Select the correct scaling and range (See Scaling):

Parameter	Type	Description	Default setting	Unit
P440:1	I/O Setup	AO1 output range	1: 0...10VDC	–
P440:2	I/O Setup	AO1 function	1: Output frequency	–
P440:3	I/O Setup	AO1 min signal	0	–
P440:4	I/O Setup	AO1 max signal	1000	–

FREQUENCY PRESETS

Define your basic preset frequency if required:

Parameter	Type	Description	Default setting	Unit
P450:1	I/O Setup	Freq. preset 01	20.0	Hz
P450:2	I/O Setup	Freq. preset 02	40.0	Hz
P450:3	I/O Setup	Freq. preset 03	50.0/60.0 *Typecode dependent	Hz
P450:4	I/O Setup	Freq. preset 04	0.0	Hz

5 FUNCTION & PARAMETER DESCRIPTION

5.1 PARAMETER / FUNCTION OVERVIEW

The VLB3 series is a multipurpose variable speed drive with a various amount of functionalities. For fast and easy commissioning the parameters are grouped. The group 0 "Favorites" contains a link to the most common used parameters. The following graphic shows an overview over the functionalities and where they can be programmed. For detailed information see the corresponding chapter.

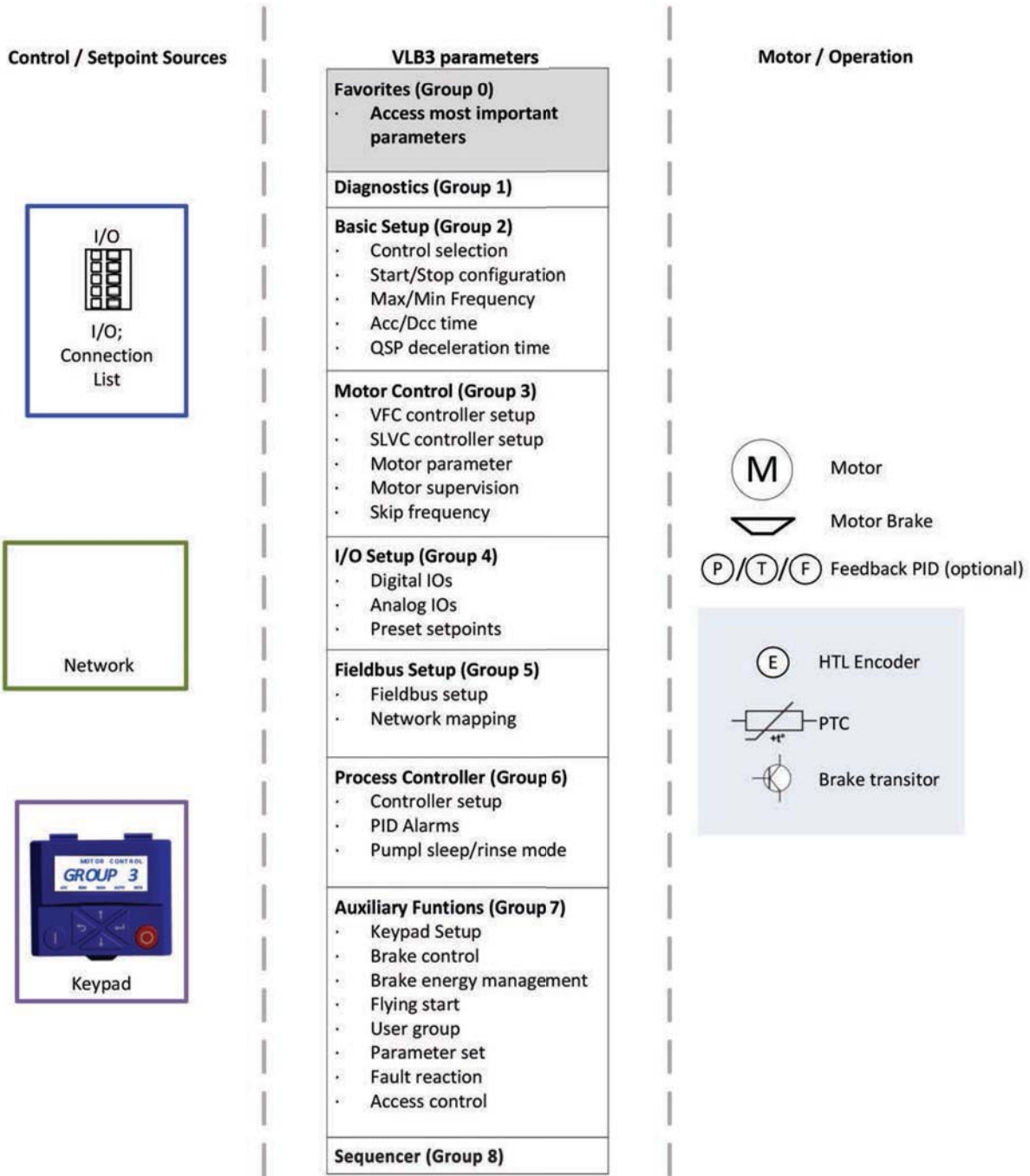

Every parameter has a hexadecimal index number. Parameters which are visible on the keypad have also a parameter number. In the VLBXSW01 software the parameter number and the hexadecimal index are visible. Every parameter can have subindex.

Example	Parameter number	Index
Base Frequency	P303.02	0x2B01:002
Control source	P200.00	0x2824:000

Parameter number	Index	Subindex
P510:1	0x2321:1	Node ID (*)
1... [1]...247		Modbus node address

I Parameter witch are not visible on the keypad are marked in the manual as P (without number).

Parameters or selections with marking (*) are not available on all control unit types.

5.2 START, STOP AND ROTATING DIRECTION COMMANDS

5.2.1 CONTROL SELECTION

The selected "control source" serves to provide the VLB3 with its start, stop, and reversal commands.

Possible control sources:

- Digital inputs
- Keypad
- Network

The following signal flow shows the internal control logics:

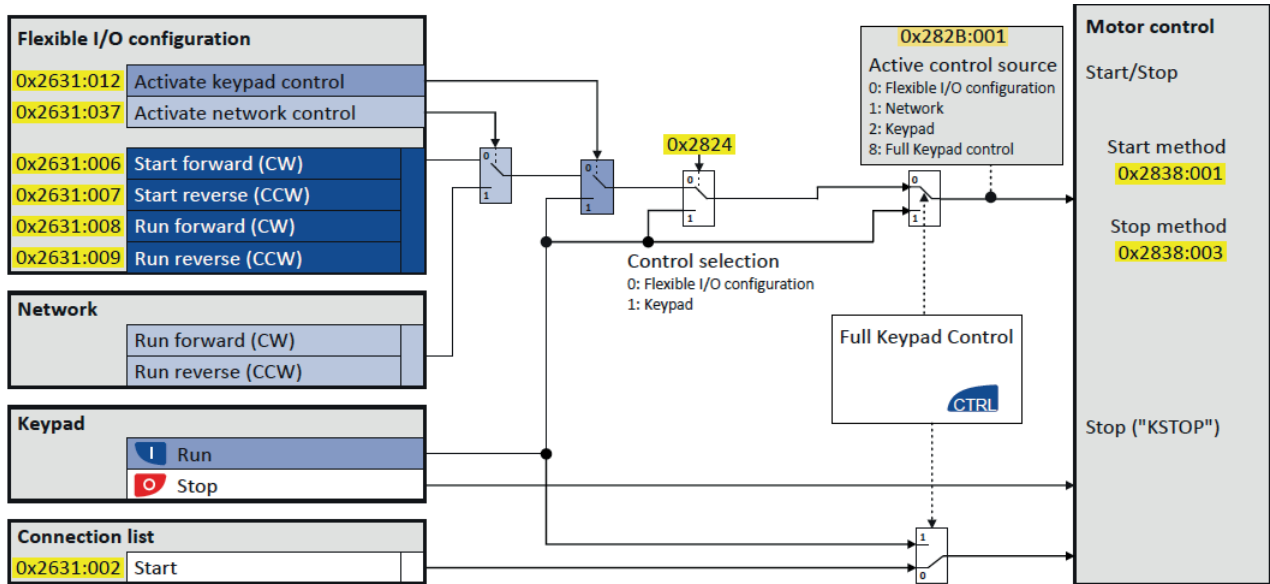

In order to control the VLB3 from the network, the network share P400:37 must be configured. It is important to note that the following functions are still active in network control mode:

- VSD enable P400:1
- Start/stop P400:2
- Activate quick stop P400:3
- Reset error P400:4
- DC-injection brake P400:5
- Jog forward (CW) P400:10
- Jog reverse (CCW) P400:11

All other function triggers are inactive while the VLB3 is in network control mode (0x2361:006 to 0x2361:025).



NOTICE!

Stop commands are always active from any connected source, regardless of which control source is selected!

If, for example, the network control is activated and a keypad is plugged in for diagnostic purposes, the motor is also stopped when the keypad key is pressed.

►Exception: a stop command has no effect in jog operation.

Details

- The default setting "Flexible I/O configuration [0]" in P200:0 enables a flexible control of the VLB3 via digital inputs, network and keypad. The control of the VLB3 via the digital inputs is preconfigured. For details see the subchapter "Flexible I/O configuration".
- If the keypad is to be used as the control source for the application, set "Keypad [1]" in P200:0. For details, see subchapter "Keypad control".
- The control source that is currently active is displayed in P125:1.

P200:00	0x2824	Control selection			
0: Flexible I/O configuration 1: Keypad		0: Flexible I/O configuration This selection enables a flexible assignment of the start, stop, and rotating direction commands with digital signal sources. - Digital signal sources can be digital inputs, network and keypad. - The I/O configuration is made via the parameters P400:xx. 1: Keypad This selection enables the motor to be started exclusively via the start key of the keypad. Other signal sources for starting the motor are ignored. Note! - The functions "Enable VSD" P400:1 and "Run" P400:2 must be set to TRUE to start the motor. - If jog operation is active, the motor cannot be stopped via the keypad key.			

5.2.2 FLEXIBLE I/O CONFIGURATION

Use parameter (P400:xx) to individually adapt the VSD control to the respective application. This is basically effected by assigning digital signal sources ("triggers") to functions of the VSD.

i A digital signal source can be assigned to several functions.
Possible consequence: unforeseeable behaviour of the drive in case of incorrect assignment

➔ Carry out assignment of a digital signal source to several functions with greater care.

Details

- Each subcode of P400 is permanently assigned to a specific function. Functions are for example "Enable VSD", "Activate quick stop" or "Start forward (CW)".
- For a function, exactly one (digital) trigger can be set:

Trigger	Function
Digital input 1	Run

- Possible triggers to be selected are for example the digital input and internal status signals of the VSD.
- A list of all triggers available can be found in the description for the parameter P400:1.
- If the trigger condition is met, the corresponding function is executed. More details with regard to the respective trigger conditions can be gathered from the functional descriptions in the following subchapters.

Example: changing the function assignment of a digital input

Task for this example:

1. The preset assignment of the digital input 3 for "Invert rotation" function is to be cancelled.
2. Instead, the digital input 3 is to be assigned to the "Activate DC braking" function.

For this purpose, the following two settings are required:

Default:

Function	Trigger	Function
P400:13	Digital input 3	Invert rotation

New:

Function	Trigger	Function
P400:13	Not connected [0]	Invert rotation
P400:5	Digital input 3 [13]	Activate DC braking

5.2.3 KEYPAD CONTROL







The "Keypad" control selection enables the motor to be started exclusively via the start key of the keypad. Other signal sources for starting the motor are ignored.

Details

If the keypad is to be used as the sole control source for the application, selection "Keypad [1]" is to be set in P200:0.

If the local keypad control is active, "LOC" is displayed in the lower status row of the keypad.

The keys on the keypad then have the following function:

Function of the keypad keys in the parameterisation mode			
Key	Actuation	Condition	Action
	Shortly	Local keypad control active. Display "LOC"	Run motor.
	Shortly	No Jog operation	Stop motor. Display "KSTOP"
	Shortly	Operating mode	Change to parameterisation mode.
	Longer than 3 s	None (anytime possible)	Save parameter settings in the user memory of the memory module.
	Shortly	During operation	Scroll through informaion in the above status line.
	Shortly	Operating mode	Activate full keypad control Display "ON?" → confirm with ↵ Control and setpoint slection can now only be carried out via keypad. Renewed clocking: Exit full keypad control. Display "OFF?" → confirm with ↵
	Shortly	Local keypad control active. Display "LOC"	Reversal of rotation direction. Display "REV?" → confirm with ↵

The following functions continue to be active:

- P400:1: Enable VSD
- P400:3: Activate quick stop
- P400:5: Activate DC braking
- P400:10: Jog foward (CW)
- P400:11: Jog reverse (CCW)
- P400:13: Reverse rotational direction
- P400:43: Activate fault 1
- P400:44: Activate fault 2

5.2.4 KEYPAD FULL CONTROL

The "Keypad Full Control" control mode can be activated with the keypad key "CTRL". Both the control and the setpoint selection are then made via the keypad. This special control mode can be, for instance, used during the commissioning phase if external control and setpoint sources are not ready to use yet.

⚠ CAUTION!

If the "Keypad Full Control" control mode is active, the "Run" P400:2 function is internally set to TRUE. In this case, the motor cannot be stopped via this function.

► For stopping the motor, use the  keypad key, deactivate the VSD enable or activate the "quick stop" function.

Details

- After the "CTRL" key has been pressed, the activation of the control mode must be confirmed with the key. (The key serves to cancel the action.)
- When the control mode is changed over, the motor is first stopped and the "Forward" direction of rotation is set. Then, the motor can be started and stopped via the keypad.

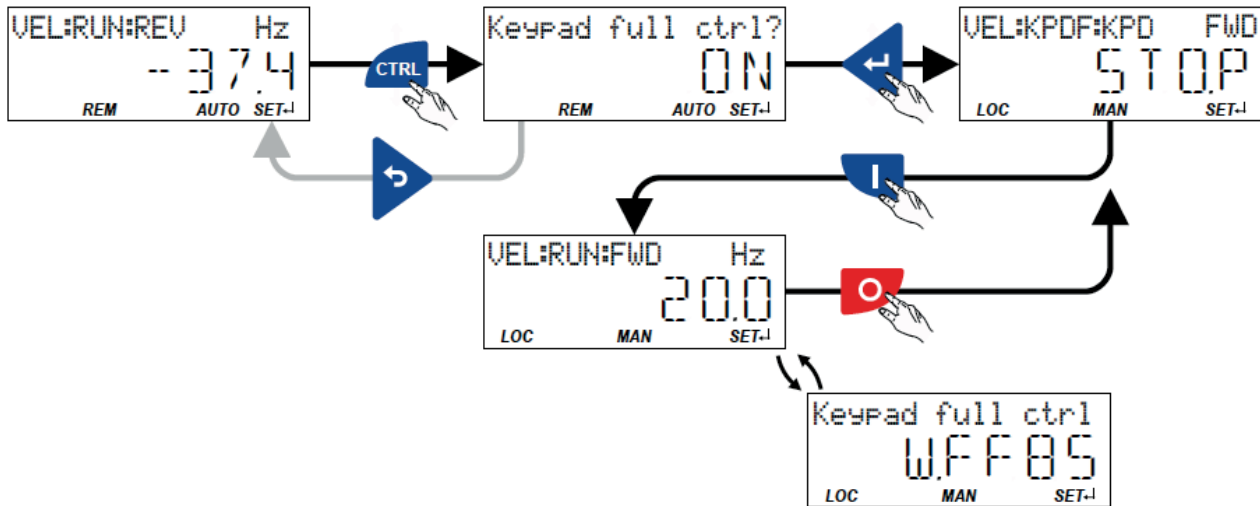

- If the "Keypad Full Control" control mode is active,
- the keypad shows the warning "Keypad full ctrl" alternately with the status display.
 - the set standard setpoint sources are ignored.
 - a change-over to other setpoint sources is not possible.
 - a change-over to network control is not possible.
 - the following functions continue to be active:
 - P400:1: Enable VSD
 - P400:3: Activate quick stop
 - P400:5: Activate DC braking
 - P400:10: Jog forward (CW)
 - P400:11: Jog reverse (CCW)
 - P400:13: Reverse rotational direction
 - P400:43: Activate fault 1
 - P400:44: Activate fault 2
- The control mode can be terminated again if the "CTRL" keypad key is pressed again.

5.2.5 FLEXIBLE I/O CONFIGURATION OF THE START, STOP AND ROTATING DIRECTION COMMANDS

Configuration of the triggers for the basic functions for controlling the motor.

Details

The following table contains a short overview of the basic functions. For more details see the parameter descriptions.

Function	Info
Enable VSD (P400:1)	Enable/disable operation. <ul style="list-style-type: none"> The function must be set to TRUE to start the motor. Either via digital input or by default setting "Constant TRUE [1]". If the function is set to FALSE, the VSD is disabled. The motor becomes torqueless (coasts). See Example 6: Enable VSD.
Run (P400:2)	Function 1: Start / stop motor (default setting) <ul style="list-style-type: none"> Function 1 is active if no further start commands (start forward/start reverse) have been connected to triggers, no keypad control is active and no network control is active. TRUE: Let motor rotate forward (CW). FALSE: Stop motor. See Example 1: Start/stop (1 signal) and reversal.
	Function 2: Start enable/stop motor <ul style="list-style-type: none"> Function 2 is active if further start commands have been connected to triggers, keypad control is active or network control is active. TRUE: Start commands of the active control source are enabled. FALSE: Stop motor. See Example 2: Start forward/start reverse/stop (edge-controlled). See Example 3: Run forward/Run reverse/stop (status-controlled).
Activate quick stop (P400:3)	Bring motor to a standstill in best time. See Example 4: Quick stop.
Start forward (P400:6)	Start motor edge-controlled. <ul style="list-style-type: none"> In order to be able to start the motor, the "Run" function must be set to TRUE.
Start reverse (P400:7)	<ul style="list-style-type: none"> The motor is stopped by resetting the "Run" function to FALSE. Functions are deactivated in case of keypad or network control. See Example 2: Start forward/start reverse/stop (edge-controlled).
Run forward (P400:8)	Let the motor rotate in a status-controlled way. <ul style="list-style-type: none"> In order to be able to start the motor, the "Run" function must be set to TRUE.
Run reverse (P400:9)	<ul style="list-style-type: none"> Functions are deactivated in case of keypad or network control. See Example 3: Run forward/Run reverse/stop (status-controlled).
Jog forward (P400:10)	Jog operation: Let the motor rotate in a status-controlled way with setpoint preset. CAUTION!
Jog reverse (P400:11)	The jog operation has a higher priority than the "Run" function, all other start commands and the keypad key  . <ul style="list-style-type: none"> If jog operation is active, the motor cannot be stopped with the previously mentioned functions! However, jog operation can be interrupted by the "Quick stop" function. Jog operation can always be activated, even in case of keypad or network control. See Example 5: Jog forward/Jog reverse.
Invert rotation (P400:13)	Invert frequency setpoint. <ul style="list-style-type: none"> Function can be used in combination with all start commands. Function is deactivated in case of network control. See Example 1: Start/stop (1 signal) and reversal.

ASSIGNMENT GUIDELINES

The error message "Trigger/functions connected incorrectly" (error code 25216 | 0x6280) is output if one of the following assignment guidelines is not observed:

- If the "flexible I/O configuration" is active as control source, the "Enable VSD" function or the "Run" function must be connected to a digital input in order that the motor can be stopped again any time!
- In case of keypad or network control, the two functions "Enable VSD" and "Run" can also be set to "Constant TRUE [1]" to start the motor.
- The use of the "Start forward (CW)" and "Start reverse (CCW)" functions excludes the use of the "Run forward (CW)" and "Run reverse (CCW)" and vice versa.

Example 1: Start/stop (1 signal) and reversal

This example shows a simple control option via two switches which should be sufficient for many applications:

- Switch S1 starts the motor in forward direction of rotation. Switch S1 in the initial position stops the motor again.
- Switch S2 switches the direction of rotation.

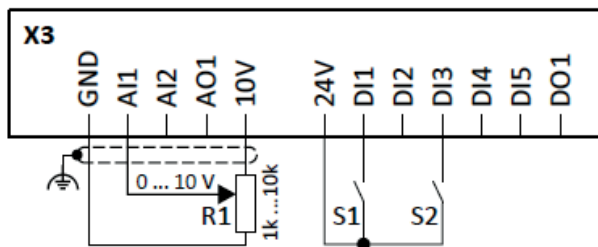

R1 = Frequency setpoint selection
 S1 = Run
 S2 = Invert rotation

The example uses the preset I/O configuration of the VSD:

Parameter	Name	Setting
P400:1	Enable VSD	Constant TRUE [1]
P400:2	Run	Digital input 1 [11]
P400:13	Invert rotation	Digital input 3 [13]

Input signals

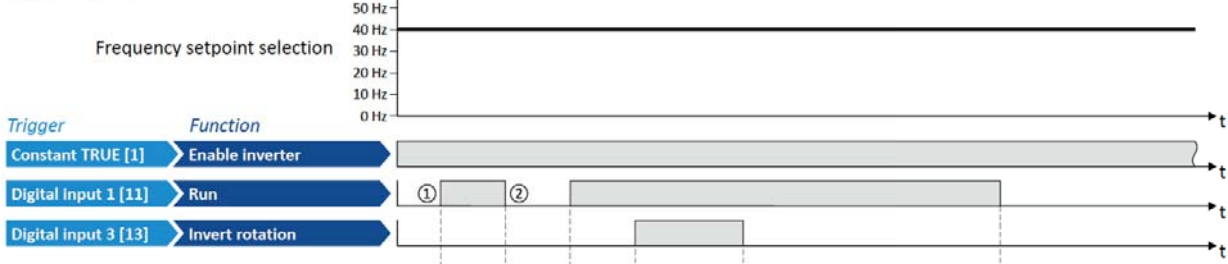

Output signals

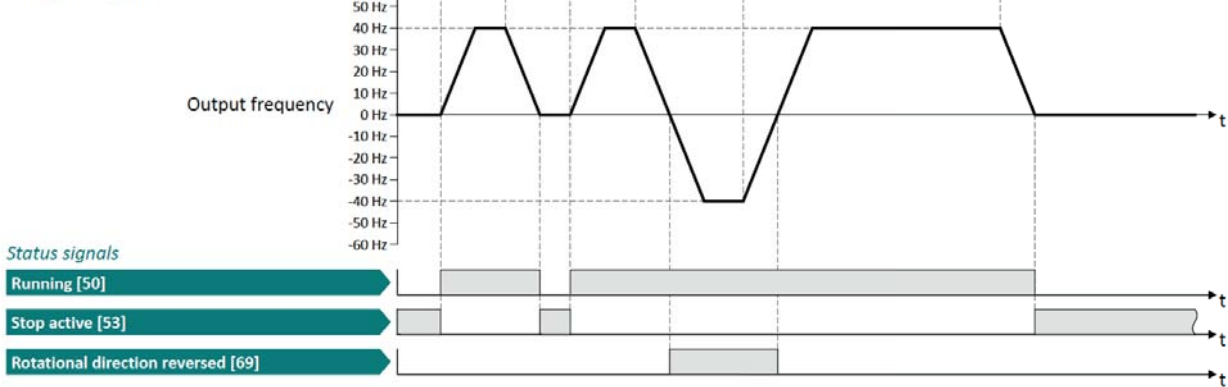

- ① If the VSD is enabled and no error is active, the motor can be started with the "Run" function in forward rotating direction.
- ② If "Run" is set to FALSE, the motor is stopped with the stop method set in P203:3. In the example: Stop with standard ramp.

Example 2: Start forward/start reverse/stop (edge-controlled)

i The "Run" function automatically becomes a "start enable" if the functions "Start forward (CW)"/ "Start reverse (CCW)" are connected to triggers.

This example shows an edge-controlled start/stop via three buttons:

- In the non-operating state of button S1 (normally-closed contact), there is already a start enable.
- Button S2 starts the motor in forward rotating direction.
- Button S3 starts the motor in backward rotating direction.
- Button S1 (normally-closed contact) stops the motor by (short-time) cancellation of the start command. The VSD then waits for the next start command via button S2/S3.

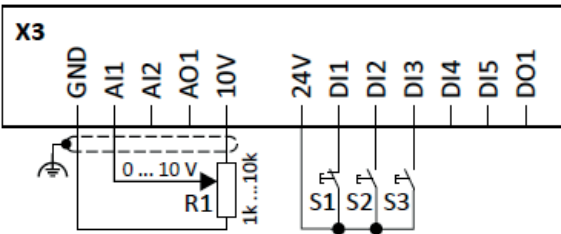

R1 = Frequency setpoint selection
 S1 = Stopping
 S2 = Start forward
 S3 = Start reverse

Parameter	Name	Setting
P400:1	Enable VSD	Constant TRUE [1]
P400:2	Run	Digital input 1 [11]
P400:4	Reset fault	Not connected [0]
P400:6	Start forward	Digital input 2 [12]
P400:7	Start reverse	Digital input 3 [13]
P400:13	Invert rotation	Not connected [0]

Input signals

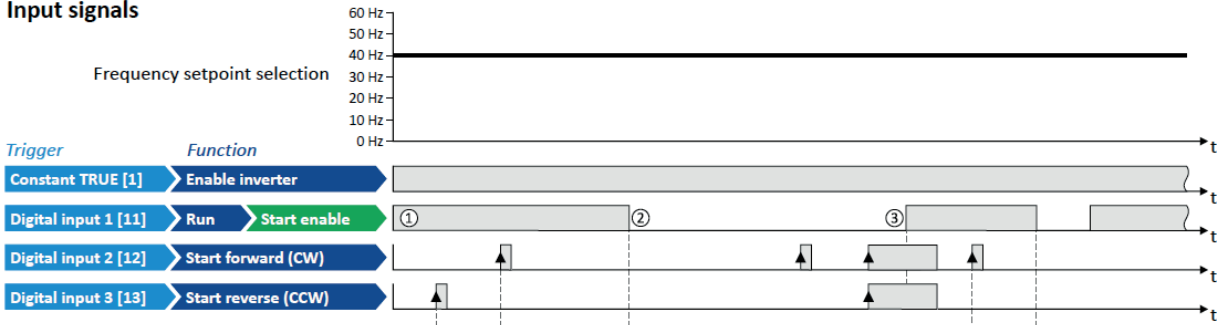

Output signals

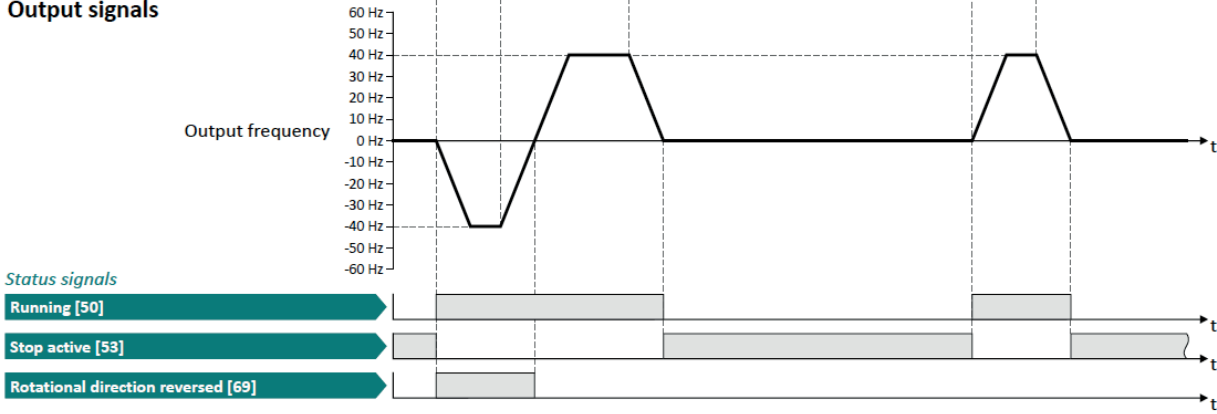

- ① The "Run" functions serves as start enable for the functions "Start forward " and "Start reverse ". Without start enable, the motor cannot be started.
- ② If the start command is cancelled, the motor is stopped with the stop method set in P203:3. In the example: Stop with standard ramp.
- ③ If, at start enable, "Start forward " and "Start reverse " are already set to TRUE, the motor remains stopped and the VSD waits for the next valid start edge.

Example 3: Run forward/Run reverse/stop (status-controlled)

I The "Run" function automatically becomes a "start enable" if the functions "Run forward (CW)"/"Run reverse (CCW)" are connected to triggers.

This example shows a status-controlled start/stop via three switches:

- Switch S1 enables the start. Without start enable, the motor cannot be started.
- Switch S2 starts the motor in forward direction of rotation.
- Switch S3 starts the motor in backward direction of rotation.
- The motor is stopped by cancelling the run commands (switches S2 and S3 open) or by cancelling the start enable (switch S1 open).

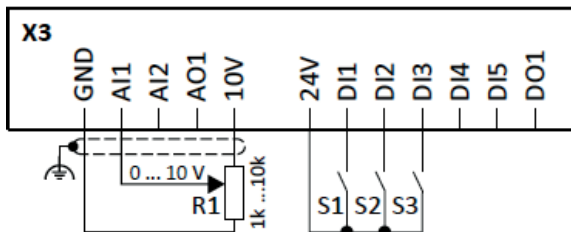

R1 = Frequency setpoint selection
 S1 = Start enable
 S2 = Run forward
 S3 = Run reverse

Parameter	Name	Setting
P400:1	Enable VSD	Constant TRUE [1]
P400:2	Run	Digital input 1 [11]
P400:4	Reset fault	Not connected [0]
P400:8	Run forward	Digital input 2 [12]
P400:9	Run reverse	Digital input 3 [13]
P400:13	Invert rotation	Not connected [0]

Input signals

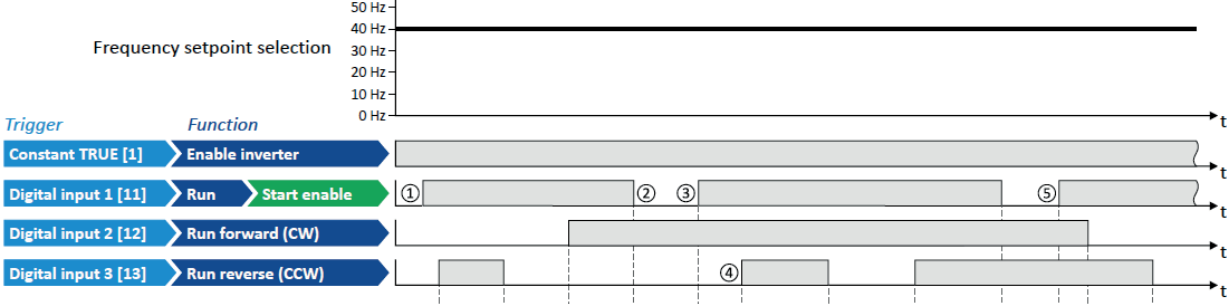

Output signals

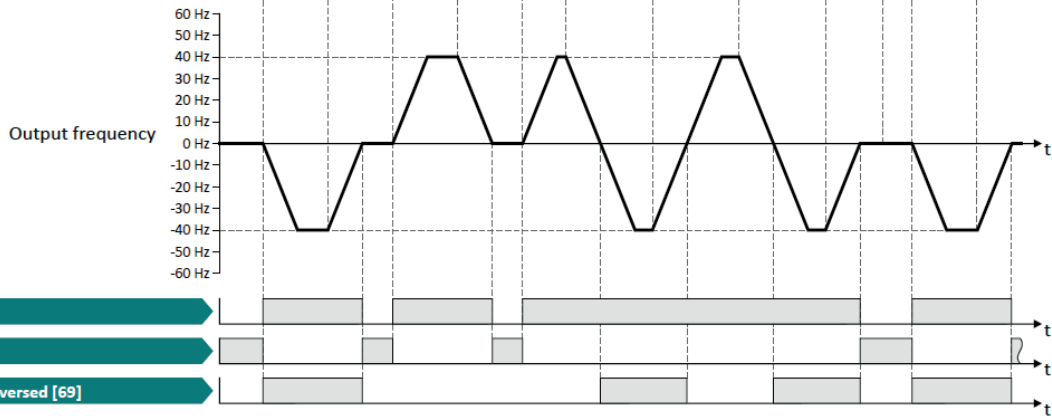

- ① The "Run" functions serves as start enable for the functions "Run forward" and "Run reverse". Without start enable, the motor cannot be started.
- ② If the start command is cancelled, the motor is stopped with the stop method set in P203:3. In the example: Stop with standard ramp. After a renewed start enable, the VSD waits for the next run command.
- ③ If, at start enable, either "Run forward" or "Run reverse" is set to TRUE, the motor starts into the triggered direction.
- ④ The VSD always responds to the run command detected last (if start enable is available). In the example, the "Run reverse" command replaces the still active "Run forward" command.
- ⑤ If, at start enable, both run commands are set to TRUE, the motor remains stopped until only one valid run command is available.

Example 4: Quick stop

This example illustrates the "quick stop" function. If quick stop is activated, the motor is brought to a standstill within the deceleration time set in P225:0.

- Switch S1 starts the motor in forward direction of rotation. Switch S1 in the initial position stops the motor again.
- Switch S2 activates the "quick stop" function.

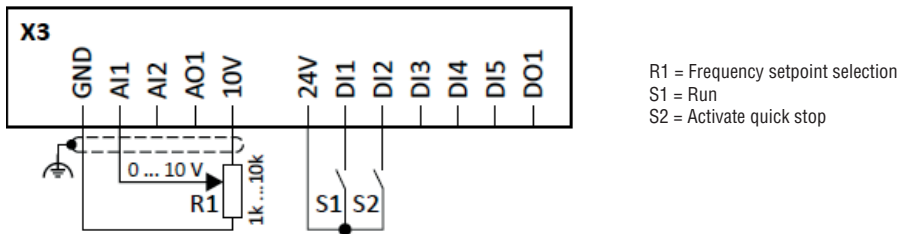

i Cancelling the quick stop causes a restart of the motor if "Run" is still active (switch S1 closed!)

Parameter	Name	Setting
P400:1	Enable VSD	Constant TRUE [1]
P400:2	Run	Digital input 1 [11]
P400:3	Activate quick stop	Digital input 2 [12]
P400:4	Reset fault	Not connected [0]
P220:0	Acceleration time 1	3.0 s
P221:0	Deceleration time 1	3.0 s
P225:0	Quick stop deceleration time	1.0 s

Input signals

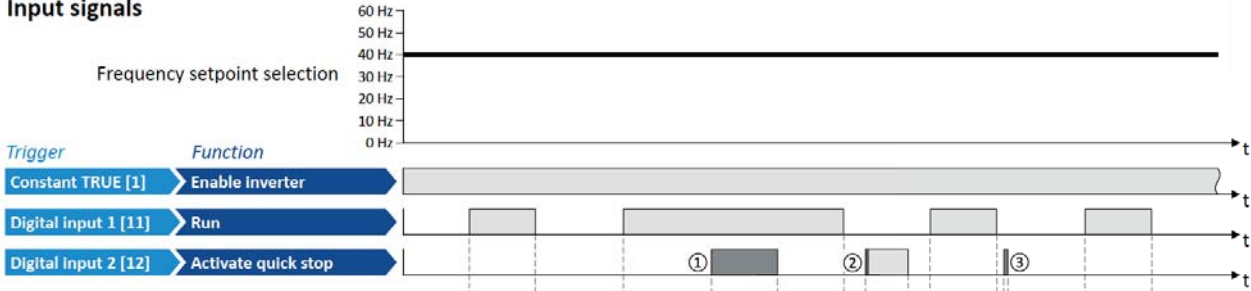

Output signals

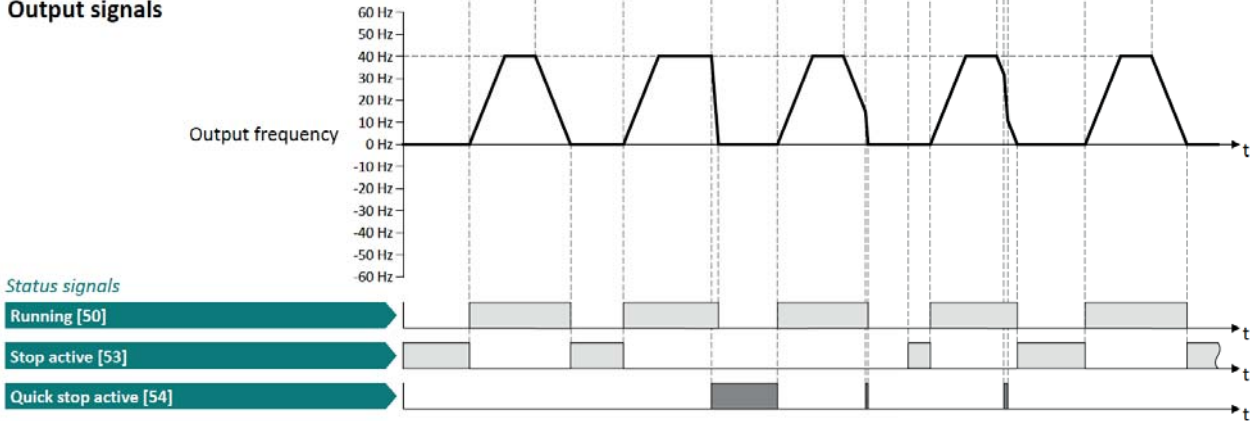

- ① If quick stop is activated, the motor is decelerated to the frequency setpoint 0 Hz within a short period of time. The "Quick stop active [54]" status is set as long as quick stop is activated. The "Stop active [53]" status is not set.
- ② An active stop command is interrupted by a quick stop.
- ③ If quick stop is cancelled again before standstill is reached, stopping is continued with the stop method set in P203:3. In the example: Stop with standard ramp.

Example 5: Jog forward/Jog reverse

This example illustrates the functions "Jog forward" and "Jog reverse" for Jog operation.

- Switch S1 starts the motor in forward direction of rotation. Switch S1 in the initial position stops the motor again.
- Button S2 starts the motor in forward direction of rotation with frequency preset 5.
- Button S3 starts the motor in backward direction of rotation with frequency preset 6.
- The motor rotates in jog operation as long as the respective button is pressed. If both buttons are pressed at the same time, the motor is stopped.

i The jog operation has a higher priority than the "Run" function, all other start commands and the keypad key .

If jog operation is active, the motor cannot be stopped with the previously mentioned functions!

- The jog operation is stopped by cancelling the functions "Jog forward"/"Jog reverse".
- The jog operation can be interrupted with the "Activate quick stop" (P400:3) function.

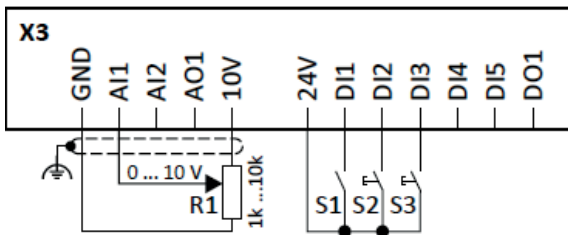

R1 = Frequency setpoint selection
 S1 = Run
 S2 = Jog forward
 S3 = Jog reverse

Parameter	Name	Setting
P400:1	Enable VSD	Constant TRUE [1]
P400:2	Run	Digital input 1 [11]
P400:4	Reset fault	Not connected [0]
P400:10	Jog forward	Digital input 2 [12]
P400:11	Jog reverse	Digital input 3 [13]
P400:13	Invert rotation	Not connected [0]
P450:5	Frequency setpoint presets: Preset 5	15 Hz (is used for jog forward)
P450:6	Frequency setpoint presets: Preset 6	10 Hz (is used for jog reverse)

Input signals

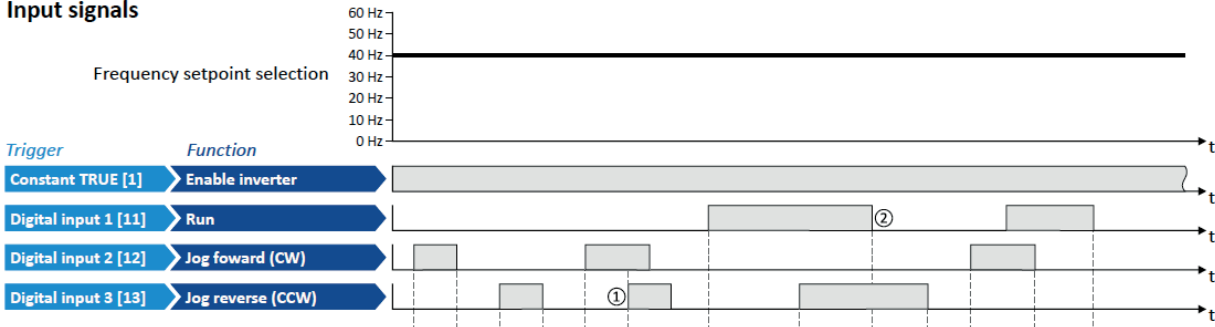

Output signals

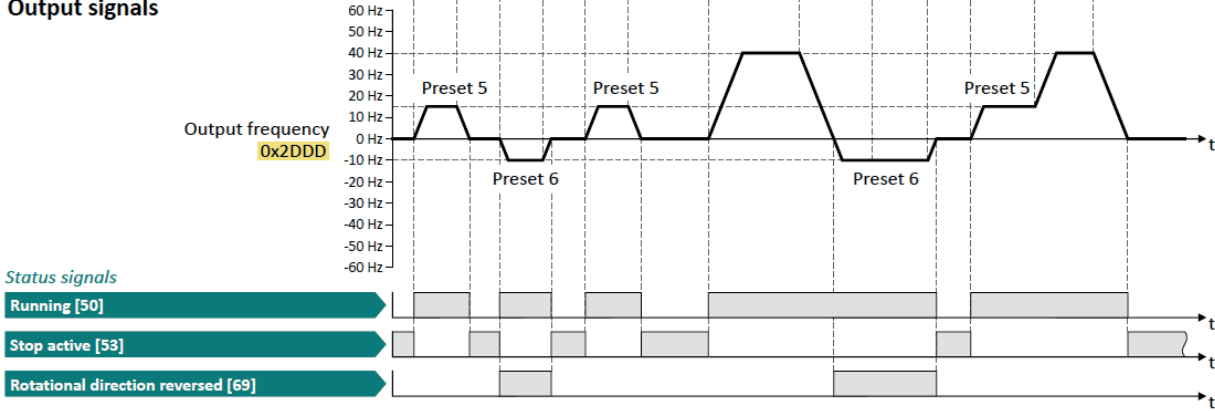

- ① If "Jog forward" and "Jog reverse" are activated at the same time, the motor is stopped with the stop method set in P203:3 and the jog operation must be triggered again.
- ② The jog operation cannot be terminated with the "Run" function but only by cancelling the jog command.

Example 6: Enable VSD

This example shows how to use the "Enable VSD" function for a separate enable input.

- In idle state of switch S1 (normally-closed contact), "Enable VSD" is already available.
- Switch S2 starts the motor in forward rotating direction (if switch S1 is closed). Switch S2 in initial position stops the motor again.
- Switch S1 disables the VSD. The motor becomes torqueless (coasts).

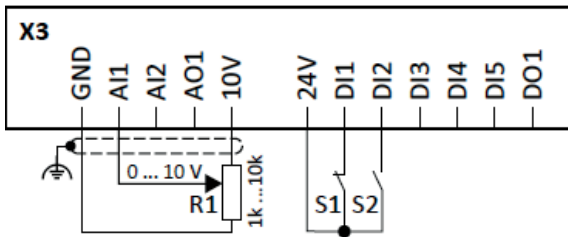

R1 = Frequency setpoint selection
 S1 = Disable VSD
 S2 = Run

Parameter	Name	Setting
P400:1	Enable VSD	Digital input 1 [11]
P400:2	Run	Digital input 2 [12]
P400:4	Reset fault	Not connected [0]

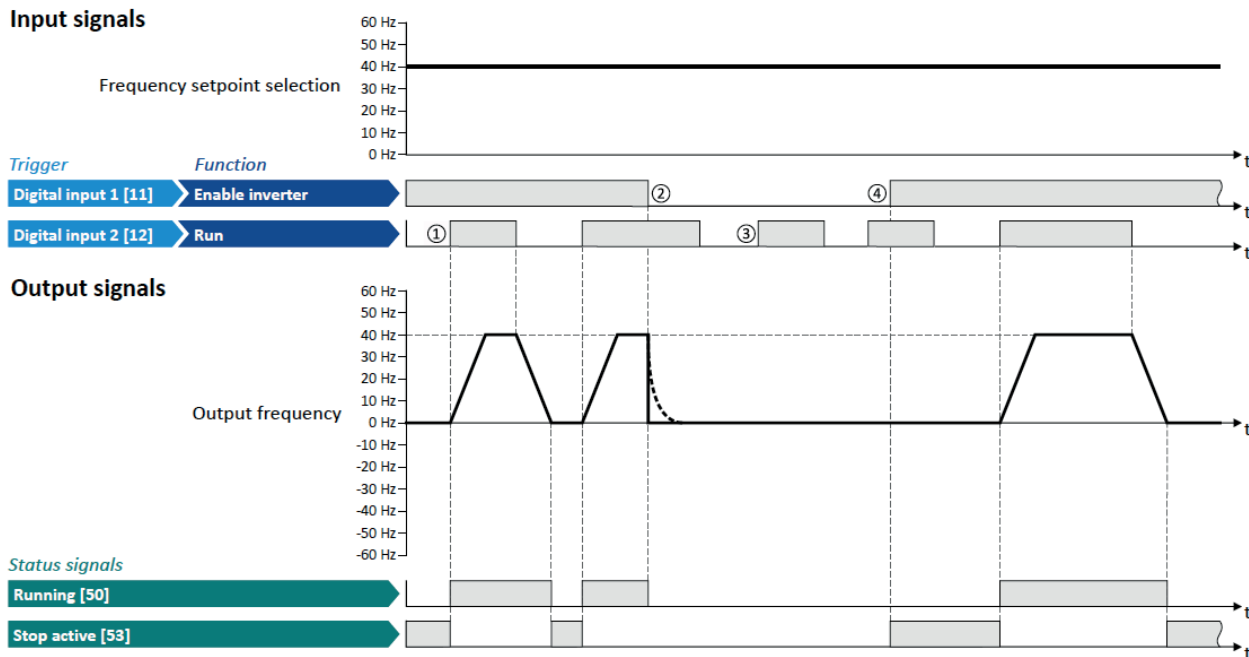

5.2.6 CONTROL/RESTRICT DIRECTION OF ROTATION OF THE MOTOR

In the default setting, both directions of motor rotation are enabled. Optionally, the direction of rotation can be restricted so that only a clockwise rotation (CW) of the motor is possible.

Preconditions

Wiring of the motor phases must be carried out correctly with regard to the direction of motor rotation.

In the documentation and the parameter selection texts, the following terms are used for the direction of rotation:

- Forward = clockwise direction of rotation (CW)
- Reverse = counter-clockwise direction of rotation (CCW)

Details

The direction of rotation of the motor can be controlled in various ways:

- Via the function "Reverse rotational direction". Possible triggers for the function "Reverse rotational direction" are available for selection in P400:13, e.g. the digital inputs and internal status signals of the drive.
- Via the network. The definition of the direction of rotation is possible via the mappable NetWordIN1 data word or one of the predefined process data words.
- By specifying a bipolar setpoint value via an analogue input. Either via a bipolar input range (-10 ... +10 V) or the configuration of a bipolar setting range.

If a reversal of rotation is not required, the direction of rotation can be restricted in P304:0 to "Only clockwise (CW)[0]".

P304:0	0x283A	Limitation of rotation			
0: Only clockwise (CW) 1: Both rotational directions		0: Only clockwise (CW) The motor can only be rotated clockwise (CW). The transfer of negative frequency and PID setpoints to the motor control is prevented. - This function takes effect after the "Reverse rotational direction" function P400:13. - Since this function only prevents negative setpoints, counter-clockwise rotation (CCW) is possible if the motor has been wired for this rotating direction. 1: Both rotational directions Both directions of motor rotation are enabled.			

5.2.7 CHANGING THE CONTROL SOURCE DURING OPERATION

The term "control sources" in this connection refers to the digital signal sources from which the VLB3 receives its start, stop, and reversal commands.

Possible control sources:

- Digital inputs
- Keypad
- Network

Details

First, select P200:0 whether the start of the motor is to be configured flexibly (default setting) or exclusively via the keypad.

If "Flexible I/O configuration" is set, a change-over from one control source to another can be effected during operation via the functions listed in the following table. The VLB3 not only supports such a change-over via its digital inputs, but also as a function of internal drive states.

Activate keypad control P400:12	Activate network control P400:37	Active control source
FALSE / Not connected	FALSE / Not connected	Flexible I/O configuration (default setting) - The motor is controlled via the digital inputs.
FALSE / Not connected	TRUE	Network - Starting the motor is only possible via the network control word. - Exception: jog operation;.
TRUE	Any	Keypad - Starting the motor is only possible via the keypad key. - Exception: jog operation.

5.2.7.1 EXAMPLE: CHANGE-OVER FROM TERMINAL CONTROL TO KEYPAD CONTROL

- The control is executed primarily via the I/O terminals: Switch S1 serves to start and stop the motor.
- Switch S2 serves to optionally change over to local keypad control. In case of activated keypad control, the motor can only be started via the keypad key. However, the condition is that switch S1 is closed.
- If switch S1 is opened again or the keypad key is pressed, the motor is stopped (irrespective of the active control source).

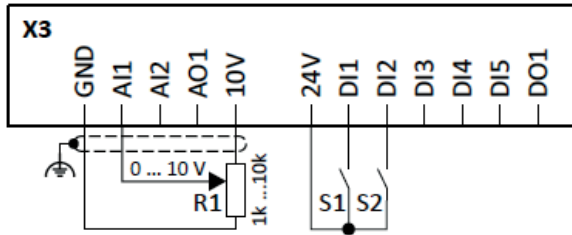

R1 = Frequency setpoint selection
 S1 = Run
 S2 = Activate keypad control

Parameter	Name	Setting
P400:1	Enable VSD	Constant TRUE [1]
P400:2	Run	Digital input 1 [11]
P400:4	Reset fault	Not connected [0]
P400:12	Activate keypad control	Digital input 2 [12]
P200:0	Control selection	Flexible I/O configuration [0]

Input signals

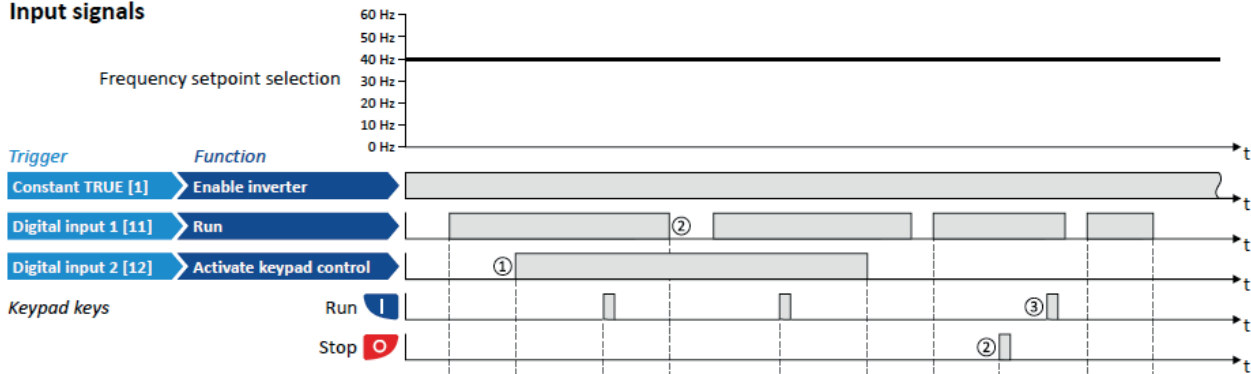

Output signals

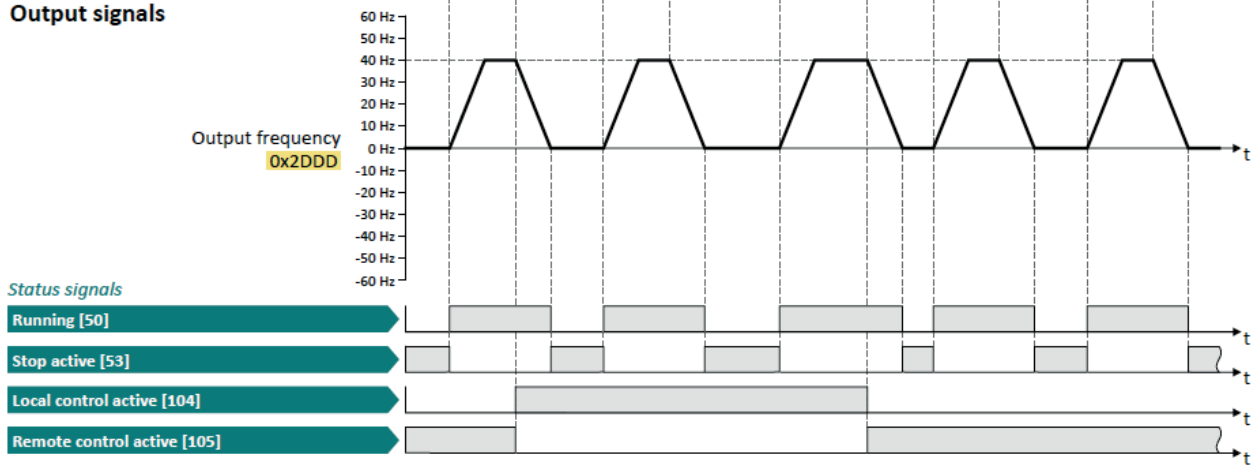

The status signals can be assigned to digital outputs.

- ① When changing over to another control source, the motor is first stopped with the stop method set in P203:3.
- ② The motor will also be stopped if the "Run" function is deactivated or the keypad key is pressed (irrespective of the active control source).
- ③ After stopping with the keypad key and before a renewed start command from another control source, the key on the keypad must be pressed to cancel the keypad stop again ("KSTOP").

5.2.7.2 EXAMPLE: CHANGE-OVER FROM TERMINAL CONTROL TO NETWORK CONTROL

- The control is executed primarily via the I/O terminals. The switch S1 serves to start and stop the motor.
- The switch S2 serves to activate the network control. In the case of activated keypad control, the motor can only be started via the network control word. However, the condition is that the switch S1 is closed.
- If the switch S1 is opened again, the motor is stopped (irrespective of the active control source).

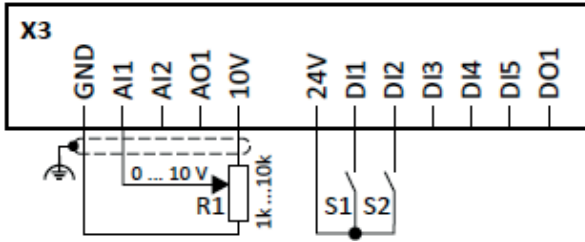

R1 = Frequency setpoint selection
 S1 = Run
 S2 = Activate network control

Parameter	Name	Setting
P400:1	Enable VSD	Constant TRUE [1]
P400:2	Run	Digital input 1 [11]
P400:4	Reset fault	Not connected [0]
P400:37	Activate network control	Digital input 2 [12]
P200:0	Control selection	Flexible I/O configuration [0]

Input signals

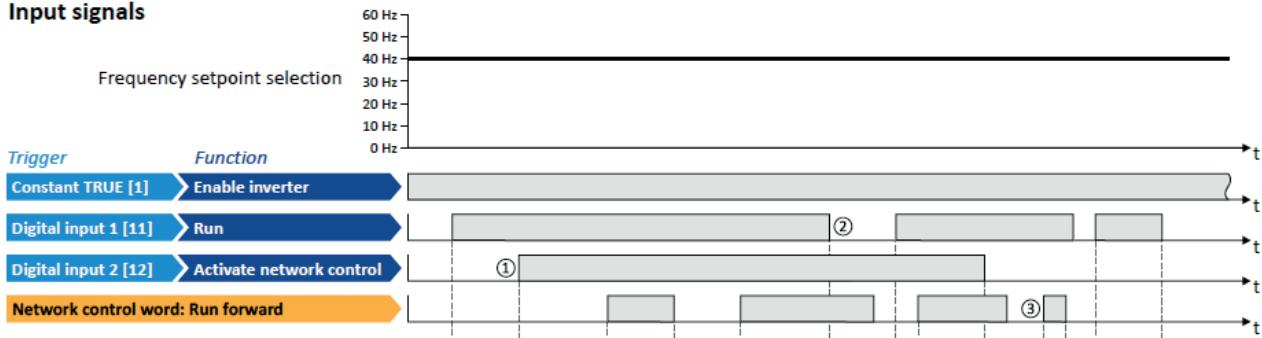

Output signals

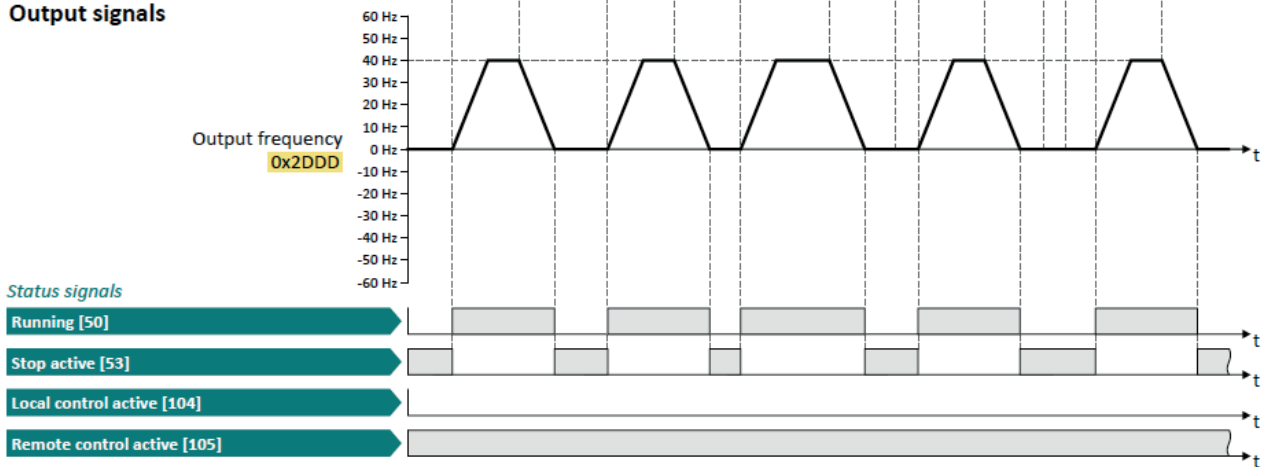

The status signals can be assigned to digital outputs.

- ① When changing over to another control source, the motor is first stopped with the stop method set in P203:3.
- ② The motor will also be stopped if the "Run" function is deactivated (irrespective of the active control source).
- ③ Commands via the network are ignored if the network control is not active.

5.3.4 ANALOG INPUT 1 DIAGNOSIS

P110:1	0x2DA4:1	Percent value			
-- ... [Actual value] ... -- %		Actual value of AI1 in % of the selected input range			
P110:2	0x2DA4:2	Frequency value			
-- ... [Actual value] ... -- Hz		Actual value of AI1 as frequency setpoint			
P110:3	0x2DA4:3	PID value			
-- ... [Actual value] ... -- P		Unit	Actual value of AI1 as PID input		
P110:4	0x2DA4:4	Torque value			
-- ... [Actual value] ... -- %		Actual value of AI1 as torque setpoint			
P110:16	0x2DA4:16	Status analog input 1			
-- ... [Actual value] ... --		Bit coded status of AI1			

5.3.5 ANALOG INPUT 2 DIAGNOSIS

P111:1	0x2DA5:1	Percent value			
-- ... [Actual value] ... -- %		Actual value of AI2 in % of the selected input range			
P111:2	0x2DA5:2	Frequency value			
-- ... [Actual value] ... -- Hz		Actual value of AI2 as frequency setpoint			
P111:3	0x2DA5:3	PID value			
-- ... [Actual value] ... -- P		Unit	Actual value of AI2 as PID input		
P111:4	0x2DA5:4	Torque value			
-- ... [Actual value] ... -- %		Actual value of AI2 as torque setpoint			
P111:16	0x2DA5:16	Status analog input 2			
-- ... [Actual value] ... --		Bit coded status of AI2			

5.3.6 ANALOG OUTPUT 1 VALUE

P112:1	0x2DAA:1	Voltage			
-- ... [Actual value] ... -- V		Actual output voltage of A01			
P112:2	0x2DAA:2	Current			
-- ... [Actual value] ... -- mA		Actual output current of A01			

5.3.7 HTL INPUT DIAGNOSTIC

P115:1	0x2642:1	Input frequency			
Actual input value at the HTL input					
P115:2	0x2642:2	Frequency setpoint			
Actual input value at the HTL input scaled at frequency value					
P115:3	0x2642:3	PID setpoint			
Actual input value at the HTL input scaled at process controller value					
P115:4	0x2642:4	Torque setpoint			
Actual input value at the HTL input scaled as torque value percent (1001. = P325:0)					

5.3.8 HEATSINK TEMPERATURE MONITORING

P117:1	0x2D84:1	Heatsink temperature			
-- ... [Actual value] ... -- °C		Actual heatsink temperature			
–	0x2D84:002	Heatsink temperature warning threshold			
50.0 ... [80.0]* ... 100.0 °C * Default setting depending on the size.		Warning threshold for temperature monitoring. – If the heatsink temperature exceeds the threshold set here, the VSD outputs a warning. – The warning is reset with a hysteresis of approx. 5 °C. – If the heatsink temperature increases further and exceeds the nonadjustable error threshold (100 °C), the VSD changes to the "Fault" device status. The VSD is disabled and thus any further operation is stopped.			

5.3.9 I/O STATUS

P118:0	0x60FD:0	Digital inputs status			
Bit # description: 16: Level at digital input 1 17: Level at digital input 2 18: Level at digital input 3 19: Level at digital input 4 20: Level at digital input 5 21: Level at digital input 6 22: Level at digital input 7 25: Low active - NPN		Status of digital input (Bit coded)			
P119:0	0x2DAC:0	Keypad status			
Bit # description: 0: Start Key 1: Stop Key 2: Up Key 3: Down Key 4: Enter Key 5: Escape Key		Keypad status (Bit coded)			
P120:0	0x2DAD:0	Internal hardware states			
Bit # description: 0: Relay 1: Digital output 1 10: Charge Relay		Status of digital outputs and relay (Bit coded)			

5.3.10 PROCESS CONTROLLER DIAGNOSIS

P121:1	0x401F:1	PID setpoint			
-- ... [Actual value] ... -- PUnit		Actual PID setpoint			
P121:2	0x401F:2	PID feedback			
-- ... [Actual value] ... -- PUnit		Actual PID feedback			
P121:3	0x401F:3	PID status			
Bit # description: 0: Process controller off 1: PID output set to 0 2: PID I-component set to 0 3: PID influence shown 4: Setpoint = actual value 5: Sleep mode active		PID status (Bit coded)			

5.3.11 MOTOR PROTECTION I2XT

P123:0	0x2D4F:0	Motor utilisation ($i^2 \cdot t$)			
-- ... [Actual value] ... -- %		Actual thermal load of the motor (I2xt)			

5.3.12 CONTROL / SETPOINT SOURCE

P125:1	0x282B:1	Active control source			
--... [Actual value] ...--		Display of the control source that is currently active. 0:Flexible I/O configuration 1:Network 2:Keypad 8:Keypad full control			
P125:2	0x282B:2	Active setpoint source			
--... [Actual value] ...--		Display of the control source that is currently active. 0:Not selected 1: Analog input 1 2: Analog input 2 3: Keypad setpoint 4: HTL input 5: Network Setpoint 11: Setpoint preset 1 12: Setpoint preset 2 13: Setpoint preset 3 14: Setpoint preset 4 15: Setpoint preset 5 16: Setpoint preset 6 17: Setpoint preset 7 18: Setpoint preset 8 19: Setpoint preset 9 20: Setpoint preset 10 21: Setpoint preset 11 22: Setpoint preset 12 23: Setpoint preset 13 24: Setpoint preset 14 25: Setpoint preset 15 31: Segment preset 1 32: Segment preset 2 33: Segment preset 3 34: Segment preset 4 35: Segment preset 5 36: Segment preset 6 37: Segment preset 7 38: Segment preset 8 39: Last segment 50: Motor potentiometer 51: PID setpoint			
P125:3	0x282B:3	Keypad LCD status			
Bit # description: 0: LOC 1: REM 2: MAN 3: Auto 4: Set		Bit-coded state of the keypad status displays. LOC=1 means local keypad control active. REM=1 means remote control via terminals, network, etc. active. MAN=1 means manual setpoint selection via keypad active. Auto=1 means automatic setpoint selection via terminals, network, etc. active. Set=1 means a parameter setting has been changed but not been saved yet in the memory module with mains failure protection.			
P125:4	0x282B:4	Active drive mode			
--... [Actual value] ...--		Display of the active drive mode. 0: "Velocity mode" active. 1: PID control active. 2: "Torque mode" active. 4: "Jog forward (CW)" or "Jog reverse (CCW)" function active.			
P125:5	0x282B:5	Most recently used control register			
--... [Actual value] ...--		Display of the network register for the control that was accessed last (e. g. 0x6040 or 0x400B:1). – Format: 0xiiii00 (iiii = hexadecimal index, ss = hexadecimal subindex) – The lowest byte is always 0x00.			
P125:6	0x282B:6	Most recently used setpoint register			
--... [Actual value] ...--		Display of the network register for setpoint selection that was accessed last (e. g. 0x6042 or 0x400B:3). – Format: 0xiiii00 (iiii = hexadecimal index, ss = hexadecimal subindex) – The lowest byte is always 0x00.			

5.3.13 VSD STATUS

P126:1	0x282A:1	Cause of disable			
Bit # description: 0: Flexible I/O: Inhibit 1: Network inhibit 2: Axis inhibit 6: DC bus fault 7: Drive not ready 8: Quick stop active 9: Motor parameter identification 10: Auto brake 12: CiA 402 disabled 13: CiA402 Quick stop inhibit 14: STO inhibit 15: CiA402 mode disabled		Cause of controller stop (Bit coded)			
P126:2	0x282A:2	Cause of quick stop			
Bit # description: 0: Flexible I/O: configuration 1: Network 2: Axis command 6: Error response		Cause of quick stop (Bit coded)			
P126:3	0x282A:3	Cause of stop			
Bit # description: 0: Flexible I/O: Start disabled 1: Flexible I/O: Run forward 2: Flexible I/O: Run reverse 3: Flexible I/O: Jog forward 4: Flexible I/O: Jog reverse 5: Network 6: Keypad 7: Control mode transition 8: End of sequence 15: Waiting for start		Cause of stop (Bit coded)			
P126:5	0x282A:5	Device status			
0: Initialisation 2: Not Ready to Switch On 3: Switch On Disabled 4: Ready to Switch On 5: Switched on 6: Operation enabled 7: Disable Operation 8: Shut Down 9: Quick stop active 10: Fault reaction active 11: Fault		Actual state of VSD			

5.3.14 DEVICE OVERLOAD MONITORING (i*t)

The VSD calculates the i^*t utilisation in order to protect itself against thermal overload. In simple terms: a higher current or an overcurrent that continues for a longer time causes a higher i^*t utilisation.



DANGER!

Uncontrolled motor movements by pulse inhibit.

When the device overload monitoring function is activated, pulse inhibit is set and the motor becomes torqueless. A load that is connected to motors without a holding brake may therefore cause uncontrolled movements! Without a load, the motor will coast.

► Only operate the VSD under permissible load conditions.

Details

The device overload monitoring function primarily offers protection to the power section.

Indirectly, also other components such as filter chokes, circuit-board conductors, and terminals are protected against overheating. Short-time overload currents followed by recovery periods (times of smaller current utilisation) are permissible. The monitoring function during operation checks whether these conditions are met, taking into consideration that higher switching frequencies and lower stator frequencies as well as higher DC voltages cause a greater device utilisation.

- If the device utilisation exceeds the warning threshold set in 0x2D40:002 (default setting: 95 %), the VSD outputs a warning.
- If the device utilisation exceeds the permanent error threshold 100 %, the VSD is disabled immediately and any further operation is stopped.
- Device overload monitoring depends on the VSD load characteristic P306:1.
- The device overload can be obtained from the configuration document.

P135:4	0x2D40:4	Device utilisation (i*t)			
-- ... [Actual value] ... -- %		Display of current device utilization			
P135:5	0x2D40:5	Device utilisation (i*t): Error response			
2: Trouble 3: Error Configuration of ixt error response		Selection of the response to be executed when the device overload monitoring function is triggered Error code: 9090 0x2382 - ixt error			
-	0x2D40:2	Device utilisation (i*t): Power unit warning threshold			
0...[95]...101%		If the device utilization exceeds the threshold set, the VSD outputs a warning. - With setting 0% or ≥100% the warning is deactivated.			

5.3.15 SEQUENCER DIAGNOSTIC

P140:1	0x2DAE:1	Sequencer diagnostics: Active step			
Read only (from version 4.1)		Display of the active step. 0 ≡ no sequence active.			
P140:2	0x2DAE:2	Sequencer diagnostics: Step time elapsed			
Read only: x.x s (from version 4.1)		Display of the time that has passed since the start of the current step.			
P140:3	0x2DAE:3	Sequencer diagnostics: Step time remaining			
Read only: x.x s (from version 4.1)		Display of the residual time for the current step.			
P140:4	0x2DAE:4	Sequencer diagnostics: Steps complete			
Read only (from version 4.1)		Display of the number of steps that have been made since the start of the sequence.			
P140:5	0x2DAE:5	Sequencer diagnostics: Steps remaining			
Read only (from version 4.1)		Display of the residual number of steps until the current sequence is completed. This includes the current step.			
P140:6	0x2DAE:6	Sequencer diagnostics: Active sequence			
Read only (from version 4.1)		Display of the active sequence. 0 ≡ no sequence active.			
P140:7	0x2DAE:7	Sequencer diagnostics: Active segment			
Read only (from version 4.1)		Display of the active segment. 0 ≡ no sequence active. 255 ≡ final sequence active.			
P140:8	0x2DAE:8	Sequencer diagnostics: Relative sequence time remaining			
Read only: x % (from version 4.1)		Display of the residual time of the sequence in [%].			
P140:9	0x2DAE:9	Sequencer diagnostics: Absolute sequence time remaining			
Read only: x.x s (from version 4.1)		Display of the residual time of the sequence in [s].			

5.3.16 ERROR CODE

P150:0	0x603F:0	Error code			
-- ... [Actual value] ... --		Actual pending error code. See chapter "Troubleshooting" for code explanation			

5.3.17 TIMER / COUNTER

On the keypad timers are displayed in the following format:

Days (d), Hours (h), Minutes (m), Seconds (s) (Example: 05d15h13m12s)

P151:1	0x2D81:1	Operating time			
-- ... [Actual value] ... -- s		Total operating time of VSD (VSD released)			
P151:2	0x2D81:2	Power-on time			
-- ... [Actual value] ... -- s		Total time that VSD was powered on			
P151:3	0x2D81:3	Control unit operating time			
-- ... [Actual value] ... -- ns		Total time that control unit was powered on. It includes the time where the control section is powered by USB adapter.			
P151:4	0x2D81:4	Switching Cycles			
-- ... [Actual value] ... --		Total number of power cycles			
P151:5	0x2D81:5	Relay switching cycles			
-- ... [Actual value] ... --		Total number of relay switchings			
P151:6	0x2D81:6	Short-circuit counter			
-- ... [Actual value] ... --		Total number of short circuit detections			
P151:7	0x2D81:7	Earth fault counter			
-- ... [Actual value] ... --		Total number of earth faults			
P151:8	0x2D81:8	Clamp counter			
-- ... [Actual value] ... --		Total number of active clamping			
P151:9	0x2D81:9	Fan operating time			
-- ... [Actual value] ... -- s		Total time of running fan			

5.3.18 HISTORY BUFFER

P155:0	0x2006:0	Error history buffer			
-- ... [Actual value] ... --		See chapter "Troubleshooting"			

5.3.19 DEVICE DATA

P190:1	0x2000:1	Product code			
-- ... [Actual value] ... --		Product code of VSD (If control unit and power unit were ordered separately it will indicate XXXXXXXXXXXXXXXXXXXX)			
P190:2	0x2000:2	Serial number			
-- ... [Actual value] ... --		Serial number of VSD Example: 0000000000000000XYZYZ			
P190:4	0x2000:4	Ctrl unit firmware version			
-- ... [Actual value] ... --		Example: 01.00.01.00			
P190:5	0x2000:5	Control unit - firmware type			
-- ... [Actual value] ... --		Example: IOFW51AC10			
P190:6	0x2000:6	Ctrl unit bootloader version			
-- ... [Actual value] ... --		Example: 00.00.00.13			
P190:7	0x2000:7	Control unit- bootloader type			
-- ... [Actual value] ... --		Example: IOBL51A0nn			
P190:8	0x2000:8	Object directory version			
-- ... [Actual value] ... --		Example: 108478			
P190:10	0x2000:10	Power unit- firmware version			
-- ... [Actual value] ... --		Example: 00196			
P190:11	0x2000:11	Power unit - firmware type			
-- ... [Actual value] ... --		Example: IDFW5AA			
P190:12	0x2000:12	Power Unit bootloader vers.			
-- ... [Actual value] ... --					
P190:13	0x2000:13	Power unit - bootloader type			
-- ... [Actual value] ... --					
P190:14	0x2000:14	Firmware version			
-- ... [Actual value] ... --		Firmware version of the plugged-in module (e.g. Wi-Fi module)			

5.3.20 DEVICE NAME

P191:0	0x2001:0	Device name			
-- ... [My Device] ... --		Configurable name of VSD			

5.3.21 DEVICE MODULE

P192:4	0x2002:4	Control unit - type code			
-- ... [Actual value] ... --		Type code of control unit			
P192:5	0x2002:5	Power unit - product code			
-- ... [Actual value] ... --		Type code of power unit			
P192:6	0x2002:6	Control unit - serial number			
-- ... [Actual value] ... --					
P192:7	0x2002:7	Power unit - serial number			
-- ... [Actual value] ... --					

5.3.22 ADDITIONAL STATUS

P197:0	0x2040:0	Access protection status			
Bit # description: 0: Full write access protected 1: Write access only for favorites		Actual status of access protection 0 = No protection 1 = Only read access to all parameters 2 = Only read & write access on favorites group			
P198:0	0x2827:0	Loaded parameter status			
0: User settings 1: Reset 60 Hz Settings 2: Reset 50 Hz Settings 3: OEM Settings		Actual loaded parameter settings			

5.4 GROUP 2 – BASIC SETUP

5.4.1 DEFAULT CONTROL SOURCE

P200:0	0x2824:0	Control source		
0: Flexible 1: Keypad		Defines the default Control Source for Start, Stop and Rotation direction. The VSD can be controlled from several sources such as terminals (Digital Inputs), Fieldbus or Keypad. 0: Flexible Control Start / Stop and rotation direction configured in P400.xx 1: Keypad Local or remote mounted keypad provides the start / stop commands to the VSD. Other sources for starting the VSD are ignored in this mode. NOTE: Digital Input "VSD Enable" (P400:1), "Run/Stop" (P400:2) and Keypad Stop are always active!		

5.4.2 DEFAULT SETPOINT SOURCE

The default setpoint selects the setpoint sources that will become active when no other setpoint is selected by any other means. The default setpoint values can come from external sources (Analog Inputs, Network, etc.) and internal sources (Presets).

P201:1	0x2860:1	Frequency control: Default setpoint source		
1: Keypad frequency setpoint 2: Analog input 1 3: Analog input 2 4: HTL input 5: Network frequency setpoint 11: Preset frequency val. 1 12: Preset frequency val. 2 13: Preset frequency val. 3 14: Preset frequency val. 4 15: Preset frequency val. 5 16: Preset frequency val. 6 17: Preset frequency val. 7 18: Preset frequency val. 8 19: Preset frequency val. 9 20: Preset frequency val. 10 21: Preset frequency val. 11 22: Preset frequency val. 12 23: Preset frequency val. 13 24: Preset frequency val. 14 25: Preset frequency val. 15 31: Segment preset 1 32: Segment preset 2 33: Segment preset 3 34: Segment preset 4 35: Segment preset 5 36: Segment preset 6 37: Segment preset 7 38: Segment preset 8 50: Motor potentiometer (MOP)		Default Frequency setpoint 1: Keypad frequency setpoint Setpoint by Up and Down buttons on the optional local or remote keypad 2: Analog input 1 Selects analog input 1 as default setpoint. 3: Analog input 2 Selects analog input 2 as default setpoint. 4: HTL input (from V4.1) The digital inputs DI3 and DI4 can be configured as HTL input to use an HTL encoder as setpoint encoder or define the setpoint as reference frequency ("pulse train") 5: Network frequency setpoint Selects the network as default setpoint Frequency: 11..25: Preset val. 1..15 Selects the preset values defined in P450:1 - P450:15 as default setpoint PID: 11..18: Preset PID setpoint 1..18 Selects the preset values defined in P451:1 - P451:8 as default setpoint Torque: 11..18: Preset torque setpoint 1..18 (from V4.1) Selects the preset values defined in P452:1 - P452:8 as default setpoint 31-38: Preset segment (from V4.1) Select sequencer segment setting as default setpoint 50: Motor potentiometer (MOP) Default setpoint defined by MOP (Motorized potentiometer function). Two digital inputs (increase/decrease) control the setpoint		
P201:2	0x2860:2	PID control : Default setpoint source		
(Reference see P201:1)		Default PID setpoint		
P201:3	0x2860:3	Torque control : Default setpoint source		
(Reference see P201:1) (from V4.1)		Default torque setpoint		

5.4.3 KEYPAD SETPOINTS

P202:1	0x2601:1	Keypad setpoint: frequency setpoint		
0.0 ... [20.0] ... 599.0 Hz		Default setting of the keypad setpoint for the operating mode P301:0 = "MS: Velocity mode [-2]".		
P202:2	0x2601:2	Keypad setpoint: process controller setpoint		
-300.00 ... [0.00] ... 300.00 PID unit		Default setting of the keypad setpoint for the reference value of the PID control.		
P202:3	0x2601:3	Keypad setpoint: torque setpoint		
-400.00 ... [100.0] ... 400.0 % (from version 4.1)		Default setting of the keypad setpoint for the operating mode P301:0 = "MS: Torque mode [-1]". 100% = Motor rated torque.		

5.4.4 START AND STOP CONFIGURATION

STARTING PERFORMANCE

The start can be optionally made with DC braking or flying restart circuit. Moreover, an automatic start can be activated after switch-on. The start method can be selected in P203:1. The following chart demonstrates the different start methods.

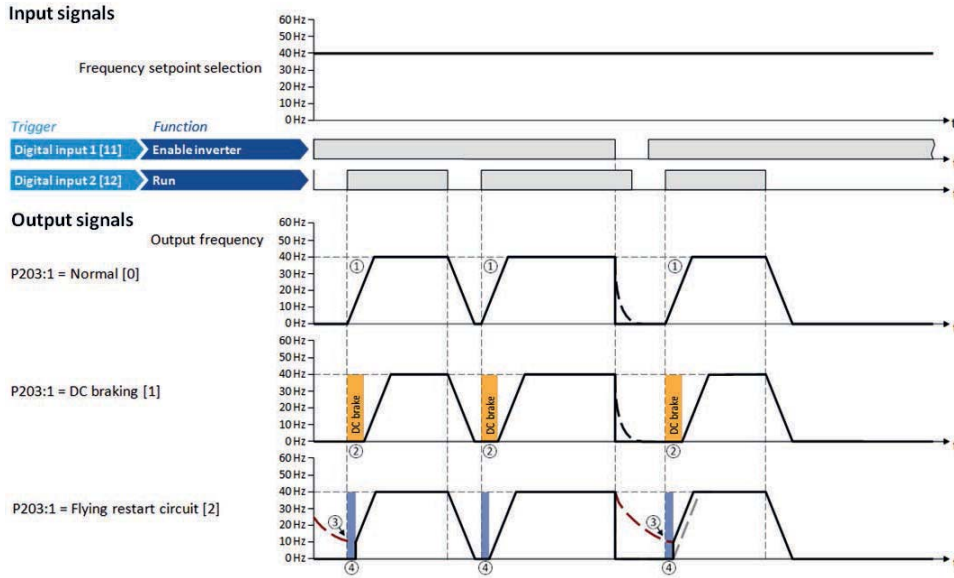

- ① Start method = "Normal [0]": After the start command, the motor is accelerated to the setpoint with the set acceleration time.
- ② Start method = "DC braking [1]": After the start command, the "DC braking" function is active. Only after the hold time set in P704:2 has elapsed, the motor is accelerated to the setpoint with the set acceleration time.
- ③ For demonstrating the flying restart circuit: at the time of the start command, the motor is not at standstill (for instance by loads with high inertia such as fans or flywheels).
- ④ Start method = "Flying restart circuit [2]": After the start command, the flying restart circuit is active. The flying restart circuit serves to restart a coasting motor on the fly during operation without speed feedback. The synchronicity between VSD and motor is coordinated so that the transition to the rotating motor is effected without jerk at the time of connection.

P203:1	0x2838:1	Start method			
0: Normal 1: Start with DC brake 2: Flying Start		Defines starting method of the motor			
		0: Normal: VSD accelerates the motor in the selected direction when the start is initiated			
		1: Start with DC brake: VSD apply the DC Brake when the start is initiated, before beginning rotation of the motor. When the DC Brake delay time has elapsed the acceleration of the motor will begin. To activate DC Brake also P704:1 and P704:2 need to be set.			
		2: Flying Start: VSD can start on a rotating motor. During start the VSD detects the actual frequency and catches the motor. This feature provides smoother starting for high inertia loads like fans, flywheels, etc...			

➔ See chapter "5.9.5 DC Brake setup", or DC brake setup.

5.4.4.1 START ON POWER UP

The automatic start can be activated in P203:2.

Preconditions for the automatic start:

- Flexible I/O configuration is selected: P200:0 = "Flexible I/O configuration [0]"
- For the start command, a digital input has been configured (In case of keypad or activated network control, an automatic start is not possible.)

The following diagram demonstrates the function.

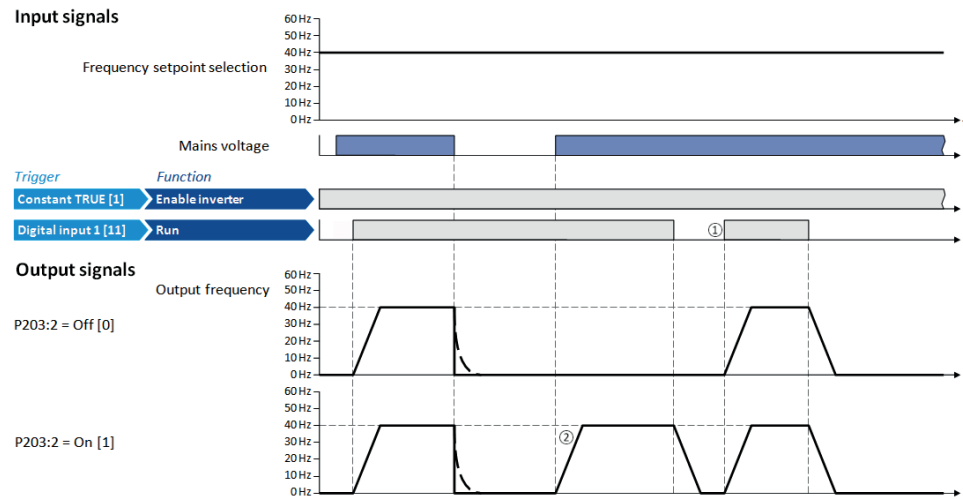

- ① Start at power-up = "Off [0]": After switching on the mains voltage, a renewed start command is required to start the motor.
- ② Start at power-up = "On [1]": After switching on the mains voltage, the motor starts automatically if a start command is active.

P203:2	0x2838:2	Start on Power up			
0: Off 1: On		Configuration of "Start on Power" function			
		0: Off Already present start/run signal upon application of mains power are ignored. The VSD needs a new start/run signal to start.			
		1: On The VSD starts automatically when mains power is applied and a valid start/run command is present.			

5.4.4.2 STOPPING PERFORMANCE

In the default setting, the motor is brought to a standstill after a stop command with standard ramp.

Alternatively, coasting or ramping down with quick stop ramp can be selected with parameter P203:3. The following diagram demonstrates the different stop methods.

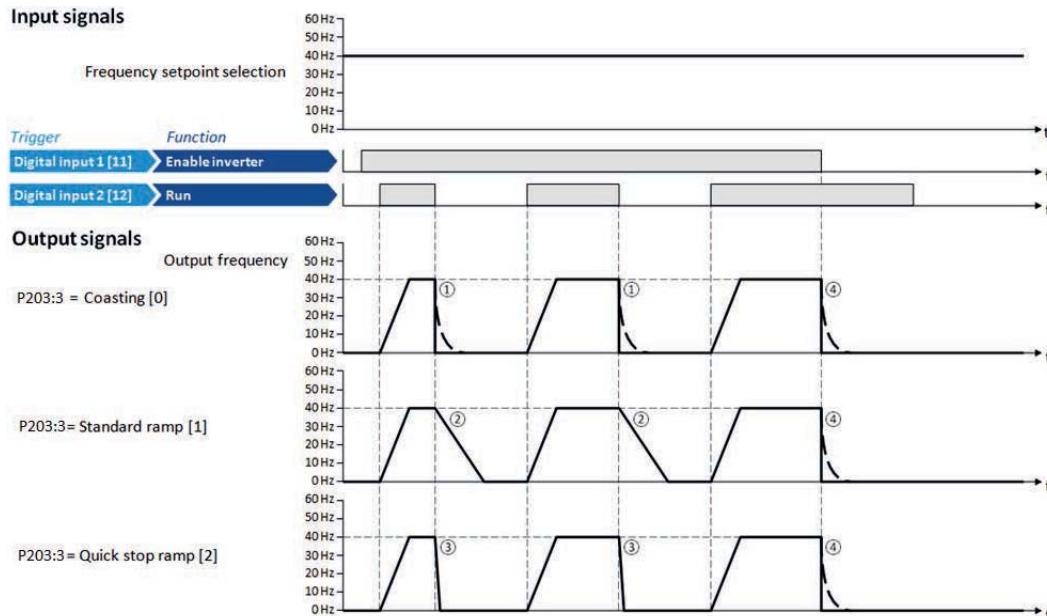

- ① Stop method = "Coasting [0]": The motor is coasting.
- ② Stop method = "Standard ramp [1]": The motor is brought to standstill with a deceleration time 1 (here: 10s).
- ③ Stop method = "Quick stop ramp [2]": The motor is brought to standstill with the deceleration time for quick stop (here: 1s).
- ④ If "Enable VSD" is set to FALSE, the VSD is disabled. The motor becomes torqueless and coasts to standstill depending on the mass inertia of the machine (irrespective of the set stop method).

P203:3	0x2838:3	Stop method			
0: Coasting 1: Standard ramp 2: Quick stop ramp		Defines the stopping method of the motor			
		0: Coasting VSD will shut off the output of the motor and the motor will coast to stop based on the inertia of the machine.			
		1: Standard Ramp VSD will ramp down the motor according to the selected deceleration time P221:0 or P223:0.			
		2: Quick stop Ramp VSD will ramp down the motor according to the quick stop ramp P225:0.			

5.4.5 MAINS VOLTAGE

The rated mains voltage set for the variable speed drive has an impact on the operating range of the VLB3.

By default, the rated mains voltage in P208:01 is set according to the product code of the VLB3.

The following results from the rated mains voltage set:

- The error threshold for monitoring the DC-bus voltage and
- The voltage threshold for braking operation ("brake chopper threshold").

Monitoring of the DC-bus voltage

- The warning thresholds for monitoring are adjustable.
- The error thresholds and reset thresholds for monitoring result from the rated mains voltage set in P208:01.
- If the DC-bus voltage of the VLB3 falls below the undervoltage error threshold, the "Trouble" response is triggered.
- Without external 24-V supply: the motor behaves according to P203:02.
- With external 24-V supply: at undervoltage, the motor behaves according to "Trouble" response.
- If the DC-bus voltage of the VLB3 exceeds the overvoltage error threshold, the "Fault" response is triggered.

i The motor does not restart automatically after the overvoltage monitoring function has been activated.

P208:1	0x2540:1	Rated mains voltage			
0: 230 Veff 1: 400 Veff 2: 480 Veff		Configuration of the actual applied mains voltage (VAC).			
		Note: Default value is type code dependent			
P208:2	0x2540:2	Under voltage warning threshold			
0 ... [Type Code dependent] ... 800 V		Warning threshold for undervoltage If the DC-bus voltage falls below the threshold value the VSD reports a warning. Reset of the warning is done with a hysteresis of 10V.			
P208:3	0x2540:3	Under voltage error threshold			
-- ... [Actual value] ... -- V		Error threshold for undervoltage If the DC-bus voltage falls below the threshold value the VSD changes to Error state.			
P208:4	0x2540:4	Under voltage reset threshold			
-- ... [Actual value] ... -- V		Error reset threshold for undervoltage			
P208:5	0x2540:5	Over voltage warning threshold			
0 ... [Type Code dependent] ... 800 V		Warning threshold for overvoltage If the DC-bus voltage exceeds the threshold value the VSD reports a warning. Reset of the warning is done with a hysteresis of 10V.			
P208:6	0x2540:6	Over voltage error threshold			
-- ... [Actual value] ... -- V		Error threshold for overvoltage If the DC-bus voltage exceeds the threshold value the VSD changes to Error state.			
P208:7	0x2540:7	Over voltage reset threshold			
-- ... [Actual value] ... -- V		Error reset threshold for overvoltage			

5.4.6 FREQUENCY LIMITS

Minimum Frequency and Maximum Frequency define the overall operating frequency range (Hz) of the VSD. All references setpoints (analog input frequency setpoints, preset frequency setpoints, network frequency setpoints, etc...) are limited this settings.

P210:0	0x2915:0	Minimum frequency			
0.0 ... [0.0] ... 599.0 Hz		Minimum motor frequency			
P211:0	0x2916:0	Maximum frequency			
0.0 ... [Type Code dependent] ... 599.0 Hz		Maximum motor frequency			

5.4.7 ACCELERATION / DECELERATION

Two sets of Acceleration/Deceleration ramps are available. Two ways of switching between ACC/DEC 1 and ACC/DEC 2 are available:

- External Trigger (i.e. Digital Input)
- Ramp time switch level to trigger from ACC/DEC1 to ACC/DEC2 based on Frequency

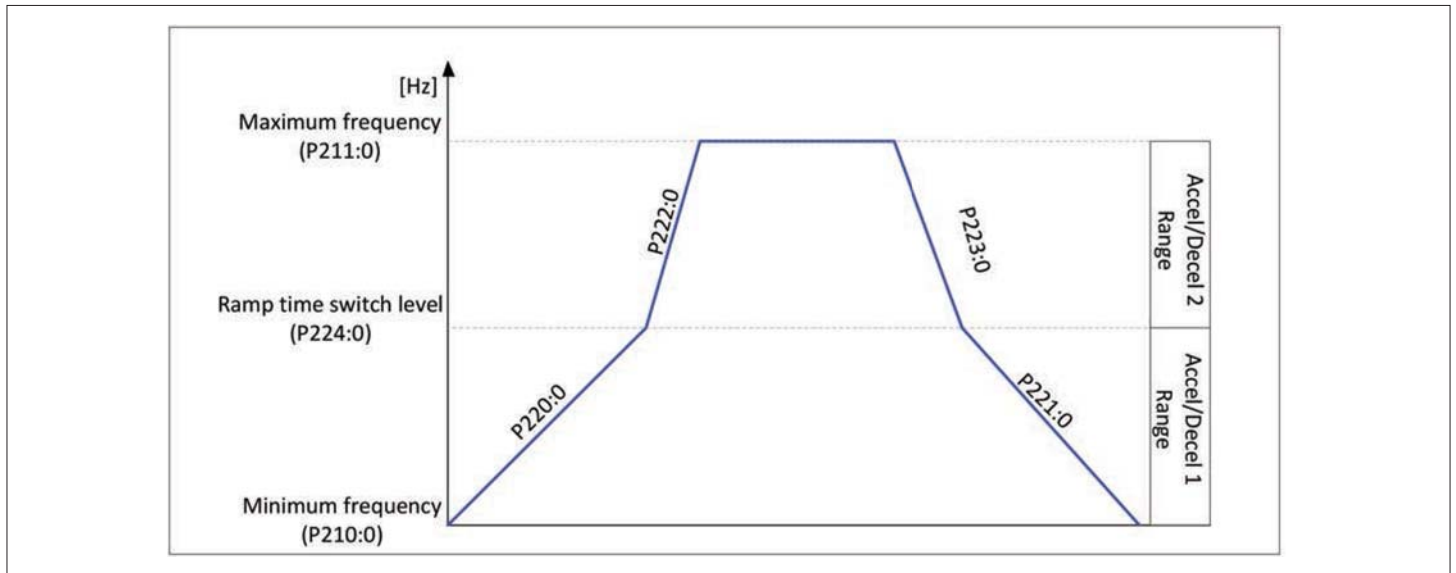

Speed setpoint

P400:39	0x2631:39	Activate ramp 2			
0: Not connected (Reference see P400:1)		Trigger for ACC/DEC2 selection: TRUE: Selects ACC2/DEC2 as ramp times			
P220:0	0x2917:0	Acceleration time 1			
0.0 ... [5.0] ... 3600.0 s		Acceleration time 1 for the output frequency to increase from 0.0 Hz to Maximum frequency (P211:0)			
P221:0	0x2918:0	Deceleration time 1			
0.0 ... [5.0] ... 3600.0 s		Deceleration time 1 for the output frequency to decrease from P211:0 Maximum Frequency to 0.0 Hz			
P222:0	0x2919:0	Acceleration time 2			
0.0 ... [5.0] ... 3600.0 s		Acceleration time 2 for the output frequency to increase from 0.0 Hz to Maximum frequency (P211:0) Note: MOP use ACC/DEC2			
P223:0	0x291A:0	Deceleration time 2			
0.0 ... [5.0] ... 3600.0 s		Acceleration time 2 for the output frequency to decrease from Maximum Frequency (P211:0) to 0.0 Hz Note: MOP use ACC/DEC2			
P224:0	0x291B:0	Ramp time switch level			
0.0 ... [0.0] ... 599.0 Hz		Switch point between ACC/DEC1 and ACC/DEC2: Act frequency < Ramp time switch level (P224:0) --> Use Accel/Decel time #1 Act frequency > Ramp time switch level(P224:0) --> Use Accel/Decel time #2 0: Function Disabled Note: Selection of ACC/DEC by P400:39, PID ACC/DEC sequencer ACC/DEC, Quickstops have higher priority			

5.4.8 QUICKSTOP RAMP TIME (QSP)

The "quick stop" function is an alternative stop method if the motor has to be stopped faster than normal.

P225:0	0x291C:0	Quick stop decel. time			
0.0 ... [1.0] ... 3600.0 s		Quick stop ramp time for the output frequency to decrease from Maximum frequency (P211:0) to 0.0 Hz Note: In Cia402 Velocity mode (P301:0 = [2] Velocity mode (vl)) the quick stop deceleration time is defined by P790:0.			

i Cancelling the quick stop causes a restart of the motor if the start command is still active and the VFD is enabled!

To activate the quick stop see Parameter P400:3.

Example for operating mode

Parameter	Name	Setting for this example
P400:1	Enable VSD	Constant TRUE [1]
P400:2	Run	Digital input 1 [11]
P400:3	Activate quick stop	Digital input 2 [12]
P203:3	Stop method	Standard ramp [1]
P211:0	Maximum frequency	50 Hz
P220:0	Acceleration time 1	4 s
P221:0	Deceleration time 1	3 s
P225:0	Quick stop deceleration time	1 s

Input signals

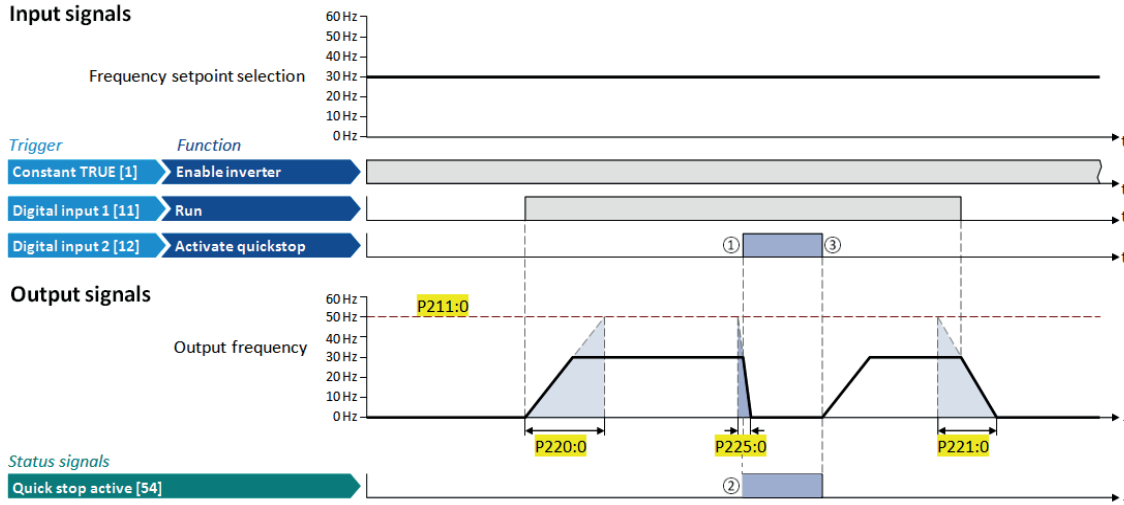

① Quick stop is activated: The motor is brought to a standstill within the deceleration time set in P225:0.

② If quick stop is active, the status signal "Quick stop active [54]" is set to TRUE. This status signal can be assigned via the Flexible I/O configuration of a function or a digital output.

③ Quick stop is deactivated again: The motor accelerates again to the setpoint since the start command is still active.

5.4.9 S-SHAPED RAMPS

In order to reduce the jerk and to therefore prevent the drive components from damage, a smoothing factor can be set for the acceleration/deceleration ramps. In the default setting, the motor is accelerated and decelerated with linear ramps since this is the most used configuration. The setting of a smoothing factor causes S-shaped ramps. This leads to a smoother starting and braking behaviour which, for instance, is used for sensitive machine parts with backlash. It has to be observed here that the setting of a smoothing factor causes longer acceleration and delay times.

Input signals

Frequency setpoint selection



Output signals

P226:1 = 0 %

Output frequency

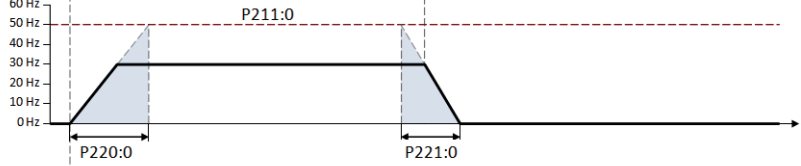

P226:1 = 50 %

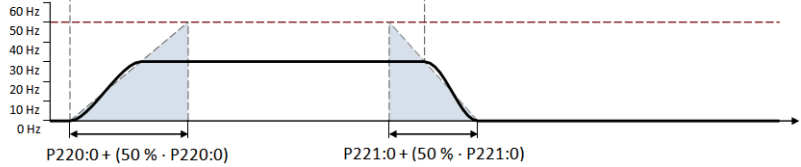

P226:1 = 100 %

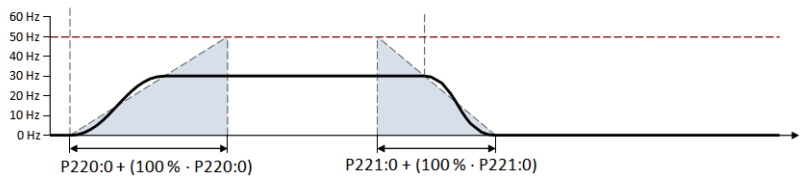

P226:1	0x291E:1	Smooth factor			
0.0 ... [0.0] ... 100.0 %		Smoothing factor for S-Shape characteristic ramping. Note: Smoothing factor will extend ramp time: 50% --> 1.5 x configured ramp time 100% --> 2 x configured ramp time			

5.4.10 OPTICAL DEVICE IDENTIFICATION

P230:1	0x2021:1	Optical tracking: start detection			
0: Stop 1: Start		If activated (Start) the led "RDY" and "ERR" starts blinking. It is useful to locate a VFD in applications including several interconnected VFD.			
P230:2	0x2021:2	Optical tracking: blinking duration			
0 ... [5] ... 3600s		Blinking duration			

5.5 GROUP 3 - CONFIGURING THE MOTOR CONTROL

This chapter contains all functions and settings relevant for the motor control.

Basic procedure of commissioning the motor control

In the first step, the rated data of the motor must be set. The other steps depend on the respective application case.

There are several options for setting the motor data and optimising the control loops. Basically, you can select between a manual and an automatic process. Whether a setting can be applied or not depends on the motor and the application. If possible, always use the possible setting listed first in the following diagram since this one leads to the most accurate results.

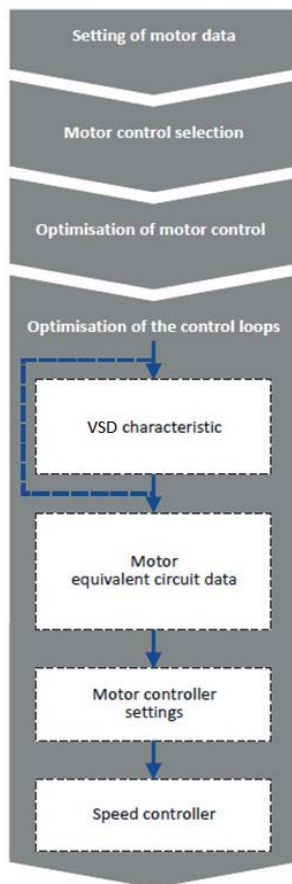

5.5.1 MOTOR DATA

The term "motor data" comprises all parameters only depending on the motor and only characterising the electrical behaviour of the machine. Motor data are independent of the application in which the VSD and the motor are used.

When you enter the motor nameplate data, take into account the phase connection implemented for the motor (star or delta connection). Only enter the data applying to the connection type selected.

P320:4	0x2C01:4	Motor rated speed			
50 ... [1450] ... 50000 rpm		Rated motor nominal speed (motor nameplate)			
P320:5	0x2C01:5	Motor rated frequency			
1.0 ... [50.0] ... 1000.0 Hz		Rated motor nominal frequency (motor nameplate)			
P320:6	0x2C01:6	Motor rated power			
0.00 ... [Type Code dependent] ... 655.35 kW		Rated motor nominal power (motor nameplate)			
P320:7	0x2C01:7	Motor rated voltage			
0 ... [Type Code dependent] ... 65535 V		Rated motor nominal voltage (motor nameplate)			
P320:8	0x2C01:8	Motor rated cosphi			
0.00 ... [0.80] ... 1.00		Rated motor nominal cosphi (motor nameplate)			
P323:0	0x6075	Motor rated current			
0.001 ... [Type Code dependent] ... 500.000 A		Rated motor nominal current (motor nameplate)			
P325:0	0x6076	Motor rated torque			
0.001...[Type Code dependent]...1000.000 Nm		Rated motor nominal torque			
P322:0	0x6080	Max motor speed			
0 ... [6075] ... 480000 rpm		Limitation of the maximum motor speed.			

5.5.2 MOTOR CONTROL MODE

P300:0	0x2C00:0	Motor control mode
2: Servo Control ASM 3: Sensorless control (SL PSM) 4: Sensorless vector control (SLVC) 6: V/f characteristic control (VFC open loop) 7: V/f characteristic control (VFC closed loop).		<p>2: Servo Control ASM This mode is used for servo control of asynchronous motor.</p> <p>3: Sensorless control (SL PSM) - Available from version 4.1 This control type is used for sensorless control of synchronous motor. Control mode is possible up to a rated power of max 22kW.</p> <p>4: Sensorless vector control (SLVC) This control type is used for sensorless vector control of an asynchronous motor.</p> <p>6: V/f characteristic control (VFC open loop) This control mode is used for the speed control of an asynchronous motor via a V/f characteristic and is the simplest control mode.</p> <p>7: V/f characteristic control (VFC closed loop). - Available from version 4.1 This control mode is used for speed control of an asynchronous motor via a V/f characteristic with a speed feedback. A motor encoder must be connected to the VFD and set as feedback system for the motor control.</p>

5.5.2.1 V/f CHARACTERISTIC CONTROL (VFC OPEN LOOP)

The V/f characteristic control is a motor control for conventional VFD applications. It is based on a simple and robust control mode for the operation of asynchronous motors with a linear or square-law load torque characteristic (e.g. fan). Because of the minimal parameterization effort, such applications can be commissioned easily and quickly.

Preconditions

- The V/f characteristic control is only suitable for asynchronous motors.
- If you want to actuate a drive with a square-law V/f characteristic: please always check whether the corresponding drive is suitable for operation with a square-law V/f characteristic!
- From the motor nameplate data, at least the rated speed and rated frequency must be entered, so that the VSD can calculate the correct number of pole pairs.
- The motor must only be actuated above the rated motor frequency/rated voltage if this is expressly approved by the motor manufacturer!

Details

This motor control type is activated by setting P300:0 = "V/f characteristic control (VFC open loop) [6]".

- P302.00 provides different characteristic shapes which are described in detail in the following subchapters.
- Limiting factors for the V/f characteristic are: rated mains voltage (P208.01), minimum frequency (P210.00) and maximum frequency (P211.00).

P302:0	0x2B00:0	V/f characteristic shape
0: Linear 1: Quadratic 2: Multipoint 3: Eco		<p>Setting can only be changed if the VFD is inhibited.</p> <p>0: Linear Linear characteristic for drives with constant load torque over the speed.</p> <p>1: Quadratic Square-law characteristic for drives with a linear or square-law load torque over the speed. - Square-law V/f characteristics are preferably used for centrifugal pumps and fan drives. - Please always check whether the corresponding drive is suitable for operation with a square-law V/f characteristic! - If your pump drive or fan drive is not suitable for operation with a square-law V/f characteristic, use the linear V/f characteristic instead.</p> <p>2: Multipoint. Linear characteristics with an additional centre characteristic point for the purpose of adaptation to specific load profiles. Available from version 4.1</p> <p>3: Eco Linear characteristic with energy optimisation in the partial load operational range.</p>
P303:1	0x2B01:1	V/f shape data: Base voltage
0 ... [Type Code dependent] ... 5000V		V/f base voltage. To be set to motor nominal voltage.
P303:2	0x2B01:2	V/f shape data: Base frequency
0 ... [Type Code dependent] ... 1500Hz		V/f base frequency. To be set to motor nominal frequency.

5.5.2.1.1 Linear V/f characteristic

Is the most used characteristic shape for general applications since they cause a torque that is largely constant.

Select V/f characteristic control with linear characteristic:

Motor control mode P300:0= "V/f characteristic control (VFC open loop) [6]"

V/f characteristic shape P302:0= "Linear [0]"

Setting of the V/f characteristic:

- Limiting factors for the V/f characteristic are: rated mains voltage (P208:1), minimum frequency (P210:0) and maximum frequency (P211:0).
- The base voltage P303:1 is usually set to the rated motor voltage (motor nameplate data). The base voltage is preset to the rated mains voltage. This again is preset according to the product key of the VSD.
- The base frequency P303:2 is usually set to the rated motor frequency (motor nameplate data).

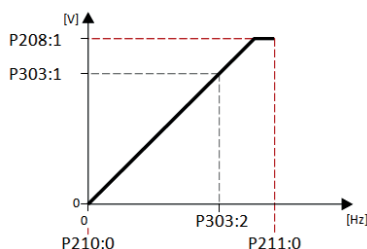

5.5.2.1.2 Square-law V/f characteristic

This is typically used in heating, ventilation and climate applications to control the speed of fans and pumps.

Each application that is provided with the features according to the affinity laws may possibly benefit from a square-law V/f characteristic.

The affinity laws describe the relation between the speed and other variables:

- The volume flow increases proportionately to the speed.
- The required pressure behaves proportionately to the square of the speed.
- The power input is proportionately to the cube of the speed. This means that already a minimal reduction of the speed may lead to substantial savings in energy consumption.

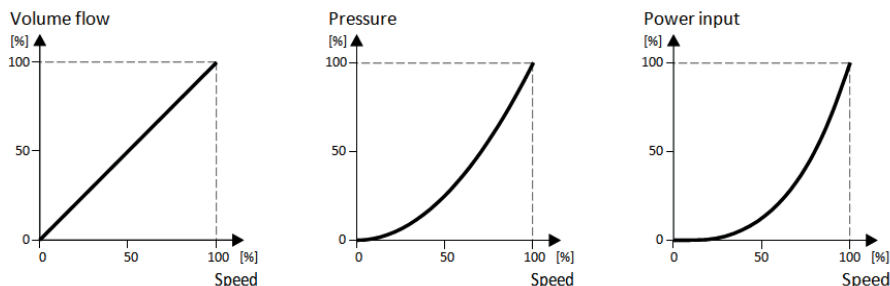

By approximation, the square-law V/f characteristic corresponds to the curve for power input shown above. At low frequencies, the voltage is reduced since due to the type of load a lower voltage is sufficient to generate the required power. All in all, this results in an energy-efficient system.

Select V/f characteristic control with square-law characteristic:

- Motor control mode P300:0 = "V/f characteristic control (VFC open loop) [6]"
- V/f characteristic shape P302:0 = "Quadratic [1]"

Setting of the V/f characteristic:

- Limiting factors for the V/f characteristic are rated mains voltage (P208:1), minimum frequency (P210:0) and maximum frequency (P211:0).
- The base voltage (P303:1) is usually set to the rated motor voltage (motor nameplate data). The base voltage is preset to the rated mains voltage. This again is preset according to the product key of the VSD.
- The base frequency (P303:2) is usually set to the rated motor frequency (motor nameplate data).

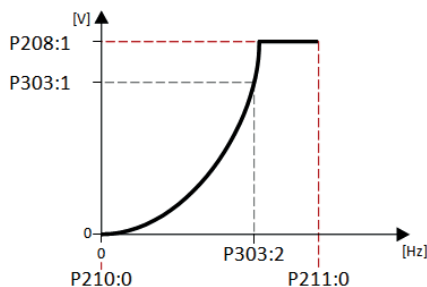

5.5.2.1.3 Multipoint user-definable V/f characteristic

It is based on the linear V/f characteristic. An additional medium characteristic point, however, enables the adaptation to applications with special torque properties.

An application case for this characteristic shape are applications that require a higher torque at lower speeds. The additional medium characteristic point can be then configured in such a way that more voltage is provided in the lower frequency range of the characteristic. Otherwise, the same limits apply for the adaptive characteristic as for the linear characteristic.

Select V/f characteristic control with adaptive characteristic:

Motor control mode (P300:0) = "V/f characteristic control (VFC open loop) [6]"

V/f characteristic shape (P302:0) = "Multipoint [2]"

Setting of the V/f characteristic:

- Limiting factors for the V/f characteristic are rated mains voltage (P208:01), minimum frequency (P210:00) and maximum frequency (P211:00).
- The base voltage (P303:01) is usually set to the rated motor voltage (motor nameplate data). The base voltage is preset to the rated mains voltage. This again is preset according to the product key of the VSD.
- The base frequency (P303:02) is usually set to the rated motor frequency (motor nameplate data).
- The additional medium characteristic point is defined based on the parameters P303:3 and P303:4.

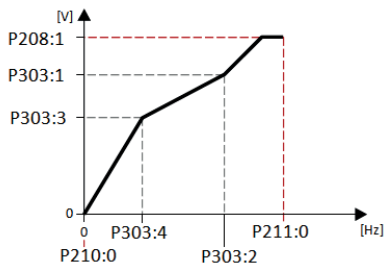

P303:3	0x2B01:3	V/f shape data: Midpoint voltage
0 ... [0] ... 5000V		Definition of the voltage of medium characteristic point for user-definable V/f characteristic. Only relevant if P302:0="Multipoint [2]". Available from version 4.1
P303:4	0x2B01:4	V/f shape data: Midpoint frequency
0 ... [0] ... 1500Hz		Definition of the frequency of medium characteristic point for user-definable V/f characteristic. Only relevant if P302:0="Multipoint [2]". Available from version 4.1

5.5.2.1.4 Energy-saving V/f characteristic - (VFC Eco)

With ECO mode the motor voltage of the VSD is detected by means of a linear characteristic as a function of the rotating field frequency or motor speed to be generated. Moreover, the motor is always driven in the optimal efficiency range via a $\cos\phi$ control and the resulting voltage reduction (reduced copper losses in the asynchronous motor).

Select energy-saving V/f characteristic control with linear characteristic:

Motor control mode P300:0 = "V/f characteristic control (VFC open loop) [6]"

V/f characteristic shape P302:0 = "Eco [3]"

Setting of the V/f characteristic:

- Limiting factors for the V/f characteristic are: rated mains voltage (P208:1), minimum frequency (P210:0) and maximum frequency (P211:0).
- The base voltage (P303:1) is usually set to the rated motor voltage (motor nameplate data). The base voltage is preset to the rated mains voltage. This again is preset according to the product key of the VSD.
- The base frequency (P303:2) is usually set to the rated motor frequency (motor nameplate data).

Eco efficiency range:

- The Eco efficiency range (grey) is between the V/f-standard characteristic (black) and the V/f Eco characteristic (green).
- The V/f Eco characteristic (green) is defined by the operating point that results from the minimum voltage (P330:1) and the base frequency (P303:2).
- The minimum voltage (P330:1) has to be set in percent with reference to the base voltage (P303:1).

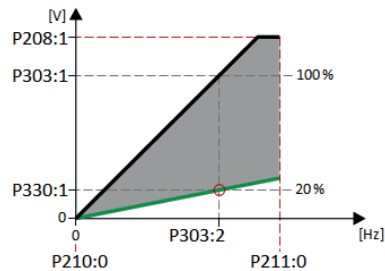

P330:1	0x2B0D:1	VFC-ECO: Minimum voltage
20 ... [20] ... 100%		Defining the operating point of the V/f ECO characteristic. The V/f ECO characteristic defines the lower limit of the eco efficiency range. 100% = Base voltage (P303:1).

5.5.2.2 V/f CHARACTERISTIC CONTROL (VFC CLOSED LOOP)

The V/f characteristic control with feedback (VFC closed loop) can be used if an asynchronous motor with motor encoder is connected to the VSD.

The speed feedback leads to the following advantages:

- Stationary speed accuracy
- Improved dynamics compared to the V/f characteristic control without feedback (VFC open loop) or to the encoderless vector control (SLVC)
- Suitability for group drives

Preconditions

- The V/f characteristic control (VFC closed loop) is only suitable for asynchronous motors.
- The V/f characteristic control (VFC closed loop) requires a feedback of the speed. A motor encoder must be connected to the VSD and set as feedback system for the motor control.
- For required settings see chapter "HTL encoder setup".
- If you want to actuate a drive with a square-law V/f characteristic: please always check whether the corresponding drive is suitable for operation with a square-law V/f characteristic!
- From the motor nameplate data, at least the rated speed and rated frequency must be entered, so that the VSD can calculate the correct number of pole pairs.
- The motor must only be actuated above the rated motor frequency/rated voltage if this is expressly approved by the motor manufacturer!

This motor control type is activated by setting P300:0 = "V/f characteristic control (VFC closed loop) [7]".

- P302:0 provides different characteristic shapes.
- Limiting factors for the V/f characteristic are rated mains voltage (P208:1), minimum frequency (P210:0) and maximum frequency (P211:0).
- The slip compensation is deactivated in this motor control type. In case of V/f characteristic control with feedback, the slip is calculated and injected by the slip regulator.

5.5.2.3 SENSORLESS VECTOR CONTROL (SLVC)

Sensorless (field-oriented) vector control for asynchronous motors is based on a decoupled, separate control for the torque-producing and the field-producing current component. In addition, the actual speed is reconstructed by means of a motor model so that a speed sensor is not required.

Preconditions

- Sensorless vector control (SLVC) is only suitable for asynchronous motors.
- Operation of the sensorless vector control (SLVC) is only permissible for one single drive!
- Operation of the sensorless vector control (SLVC) is not permissible for hoists!

Supported operating modes (P301:0):

- "MS: Velocity mode [-2]"
- "MS: Torque mode [-1]"
- "CiA: Velocity mode [2]"

This motor control type is activated by setting P300:0 = "Sensorless vector control (SLVC) [4]".

Compared to the V/f characteristics, the sensorless vector control (SLVC) serves to achieve improved drive characteristics thanks to:

- higher torque throughout the entire speed range
- higher speed accuracy and higher concentricity factor
- higher efficiency

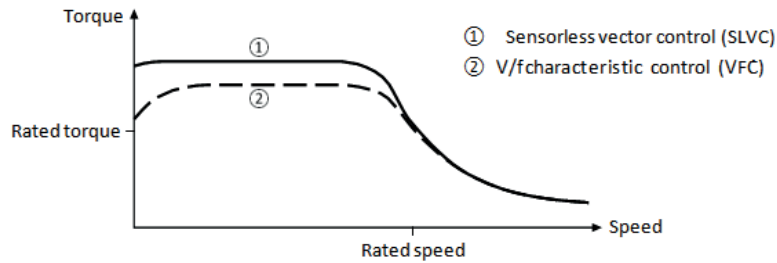

For a speed control with torque limitation in operating mode P301:0 = "MS: Velocity mode [-2]":

1. Select the source in P337:1 for the positive torque limit source and set it accordingly.
2. Select the source in P337:2 for the negative torque limit source and set it accordingly.

Alternatively, the VSD can be configured in this motor control type in such a way that it controls a motor torque within a defined frequency range. For details, see chapter "Torque control w/ freq. limit".

P337:1	0x2949:1	Positive torque limit source
0: Max torque 1: Fixed limit 0.0% 2: Analog input 1 3: Analog input 2 4: Positive torque limit 5: Network target torque		<p>Selection of the source of positive torque limit. Available from version 4.1</p> <p>0: Max torque Positive torque limit source = max torque (P326:0).</p> <p>1: Fixed limit 0.0% Positive torque limit source = 0.0%</p> <p>2: Analog input 1 The positive torque limit source is defined as analog signal via the analog input 1.</p> <p>3: Analog input 2 The positive torque limit source is defined as analog signal via the analog input 2.</p> <p>4: Positive torque limit Positive torque limit = Positive torque limit 0x60E0</p> <p>5: Network target torque The positive torque limit source is defined as process data object via network.</p>
P337:2	0x2949:2	Negative torque limit source
0: Max torque 1: Fixed limit 0.0% 2: Analog input 1 3: Analog input 2 4: Negative torque limit 5: Network target torque		<p>Selection of the source of negative torque limit. Available from version 4.1</p> <p>0: Max torque Negative torque limit source = max torque (P326:0).</p> <p>1: Fixed limit 0.0% Negative torque limit source = 0.0%</p> <p>2: Analog input 1 The negative torque limit source is defined as analog signal via the analog input 1.</p> <p>3: Analog input 2 The negative torque limit source is defined as analog signal via the analog input 2.</p> <p>4: Negative torque limit Negative torque limit = Negative torque limit 0x60E1</p> <p>5: Network target torque The negative torque limit source is defined as process data object via network.</p>
P301:0	0x6060	Modes of operation
-2: MS: Velocity mode -1: MS: Torque mode 0: No mode change / no mode assigned 2: CiA: Velocity mode		<p>Selection of the operating mode.</p> <p>-2: MS: Velocity mode Vendor specify velocity mode.</p> <p>-1: MS: Torque mode Vendor specify torque mode. Only possible in motor control type P300:0="Sensorless vector control (SLVC) [4]" Available from version 4.1</p> <p>0: No mode change / no mode assigned No operating mode (standstill).</p> <p>2: CiA: Velocity mode CiA402 velocity mode.</p>

5.5.2.4 Servo control for asynchronous motors (SC-ASM)

The field-oriented servo control is based on a decoupled, separated control of the torque-producing and field-producing current share. The motor control is based on a feedback, field-oriented and cascaded controller structure and enables a dynamic and stable operation in all four quadrants.

Preconditions

- The servo control (SC ASM) is only suitable for asynchronous motors.
- The servo control (SC ASM) is possible up to a rated power of maximally 45 kW.
- The servo control (SC-ASM) requires a feedback of the speed. A motor encoder must be connected to the VSD and set as feedback system for the motor control.
- For required settings see chapter "HTL encoder setup".

Details

This motor control type is activated by setting P300:0 = " Servo control (SC ASM)[2]".

Basically, the servo control has the same advantages as the sensorless vector control (SLVC).

Compared to the V/f characteristic control without feedback, the following can be achieved by means of the servo control:

- A higher maximum torque throughout the entire speed range
- A higher speed accuracy
- A higher concentricity factor
- A higher level of efficiency
- The implementation of torque-actuated operation with speed limitation
- The limitation of the maximum torque in motor and generator mode for speed-actuated operation

For a speed control with torque limitation in operating mode P301:0= "MS: Velocity mode [-2]":

1. Select the source in P337:01 for the positive torque limit source and set it accordingly.
2. Select the source in P337:02 for the negative torque limit source and set it accordingly.

5.5.2.5 Sensorless control for synchronous motors (SL-PSM)

The sensorless control for synchronous motors is based on a decoupled, separated control of the torque-producing current and the current in field direction. In contrast to the servo control, the actual speed value and rotor position are reconstructed via a motor model.

NOTICE

In case of this motor control type, an adjustable, constant current is injected in the lower speed range. If this current is higher than the rated motor current, the motor may heat up in the lower speed range. This effect increases if the motor is operated in the lower speed range for a longer period of time.

Possible consequence: Destruction of the motor by overheating

- Do not operate the motor for a longer period of time in the lower speed range.
- For detecting and monitoring the motor temperature, we recommend a temperature feedback via PTC thermistor or thermal contact.

Preconditions

The sensorless control for synchronous motors (SL-PSM) is possible up to a rated power of max 22kW.

This motor control type is activated by setting P300:0 = " Sensorless control (SLPSM) [3]".

The motor model-based speed observer requires a rotating machine. Thus, as a matter of principle, the operational performance of the sensorless control for synchronous motors is divided into two ranges:

1. Low speed range (Isetpoint speed < lower limit 0x2C11:001)
 - In the range of low speed, the speed of a synchronous motor cannot be observed. In this "Low speed range", an open-loop controlled operation takes place: For acceleration processes, the current set in 0x2C12:001 is injected and for processes without acceleration (for instance standstill or constant setpoint speed) the current set in 0x2C12:002 is injected.
2. High speed range (Isetpoint speed > lower limit 0x2C11:001)
 - In this area, the rotor flux position and the speed are reconstructed by means of an observer. The control is executed in a field-oriented way. Only the current required for generating the necessary torque is injected.

Pole position identification (PLI)

- For controlling a permanent-magnet synchronous motor, the pole position - the angle between the motor phase U and the field axis of the rotor - must be known.
- In case of a drive at standstill, the VSD enable is directly followed by the "pole position identification (PLI)" which identifies the initial pole position.

Flying restart circuit

- From firmware version 4.1 onwards, a flying restart circuit for the synchronous motor up to speeds lower than half the rated speed is supported.
- If the flying restart circuit shall be used, set the start method "Flying restart circuit [2]" in P203:1. More settings are not required for the flying restart circuit at sensorless control of a synchronous motor.

For a speed control with torque limitation in operating mode P301:0 = "MS: Velocity mode [-2]":

1. Select the source in P337:1 for the positive torque limit source and set it accordingly.
2. Select the source in P337:2 for the negative torque limit source and set it accordingly.

SL-PSM parameters

The parameters for this motor control type are calculated and set automatically while optimizing the control loops.

P352:1	0x2C03:1	Back EMF constant (BEMF constant)
0.0 ... [41.8] ... 100000.0 V/1000rpm		Voltage induced by the motor (rotor voltage / 1000 rpm).
	0x2C11:1	High speed range: Lower limit
5 ... [30] ... 100 %		Definition of the lower limit of the high speed range. - The lower limit has a permanent hysteresis of 5 %.
	0x2C11:2	High speed range: Tracking controller gain
0 ... [200] ... 65535 %		Gain factor for tracking the rotor position in the motor model.
	0x2C11:3	High speed range: Tracking controller reset time
0.00 ... [6.00] ... 655.35 ms		Reset time for tracking the rotor position in the motor model.
	0x2C11:4	High speed range: Tracking controller decouple time
0.0 ... [200.0] ... 6553.5 ms		Temporal hysteresis for the switching back and forth from the open-loop controlled to the closed-loop controlled operation.
	0x2C12:1	SM low speed range: Acceleration current
5 ... [70] ... 400 %		R.m.s. current value for acceleration processes in the lower velocity range. - 100 % ≙ rated motor current (P323:0). - In case of a "100 %" setting and at standstill, a motor current flows that is square root of 2 higher than the rated current. But as soon as the motor rotates, the effective rated current flows.
	0x2C12:2	SM low speed range: Standstill current
5 ... [40] ... 400 %		R.m.s. current value for processes without acceleration (for instance standstill or constant setpoint speed) in the lower velocity range. - 100 % ≙ rated motor current (P323:0)

5.5.2.5.1 Stall monitoring

The stalling monitoring for the sensorless control for synchronous motors (SL-PSM) switches off the drive if the motor is about to "stall". A possible cause may be an overload of the motor.

Preconditions

The stalling monitoring only works in the controlled area and if the motor is not operated in the field weakening range.

In order to detect the motor stalling, the cosine phi is used.

Example:

- For the cosine phi, the value "0.9" is set in P320:08 according to the data given on the motor nameplate.
- The limit value for stalling monitoring is set in 0x2C11:006 to "80 %".
- Stalling monitoring is triggered if the current cosine phi is lower than 0.72 (80 % of 0.9).

If stalling monitoring is triggered, the "Trouble" error response takes place. If the operating mode "MS: Velocity mode [-2]" is set in P301:0, the motor automatically restarts if the trouble does not exist anymore.

5.5.3 OPTIMISATION OF MOTOR CONTROL

The VSD provides different functions by means of which the drive behaviour can be further optimised.

Function	Motor control type				
	VFC open loop	VFC closed loop	SC-ASM	SL-PSM	SLVC
V/f voltage boost The parameterisable voltage boost makes it possible to improve the starting performance for applications requiring a high starting torque	●	●			
Skip frequencies By means of three parameterisable skip frequencies, critical frequencies can be suppressed which lead to mechanical resonances in the system	●	●	●	●	●
Optimising the stalling behaviour For special motors which enable an operation in the field weakening range, the behaviour in the field weakening range can be adapted to the motor	●	●			
Slip compensation In case of a load, the speed of an asynchronous motor decreases. This load-dependent speed drop is called slip. The slip compensation serves to counteract the load-dependent speed loss	●				
Oscillation damping The oscillation damping serves to reduce the oscillations during no-load operation which are caused by energy oscillating between the mechanical system (mass inertia) and the electrical system (DC bus)	●	●			
Synchronous motor: Pole position identification (PPI) For controlling a permanent-magnet synchronous motor, the pole position - the angle between the motor phase U and the field axis of the rotor - must be known. This function serves to detect the pole position for the currently activated motor encoder				●	

VFC open loop = V/f characteristic control
 VFC closed loop = V/f characteristic control with speed feedback
 SC-ASM = servo control for asynchronous motor
 SL-PSM = sensorless control for synchronous motor
 SLVC = sensorless vector control

5.5.3.1 V/f voltage boost

The voltage boost makes it possible to improve the starting performance for applications requiring a high starting torque.

Preconditions

The function is only effective in the following motor control types:

- V/f characteristic control (VFC open loop)
- V/f characteristic control (VFC closed loop)

Details

- In P316:1 a permanent voltage boost can be set. ①
- In P316:2 an additional voltage boost can be set for acceleration processes only. ②
- Reference for the percentage setting of the voltage boost is the base voltage P303:1.

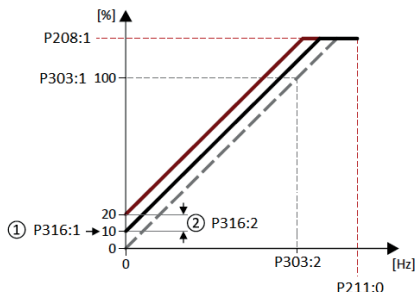

P316:1	0x2B12:1	Fixed boost
0.0 ... [Type Code dependent] ... 20.0 %		Fixed (constant) voltage boost for V/f characteristic control without feedback. - 100 % ≡ V/f base voltage (P303:01) - For the purpose of optimising the starting performance for applications requiring a high starting torque.
P316:2	0x2B12:2	V/f voltage boost: Boost at acceleration
0.0 ... [0.0] ... 20.0 %		Additional voltage boost for V/f characteristic control without feedback. - 100 % ≡ V/f base voltage (P303:1) - This voltage boost is only active while the motor is accelerated. It then acts in addition to the fixed voltage boost set in P316:1.

5.5.3.2 Skip frequencies

By means of the three skip frequencies, critical frequencies can be suppressed which lead to mechanical resonances in the system.

A blocking zone is active as soon as the frequency for this blocking zone is set to value unequal to "0 Hz".

- The set frequency defines the centre of the range to be masked out. ①
- The set bandwidth defines its total size. ②

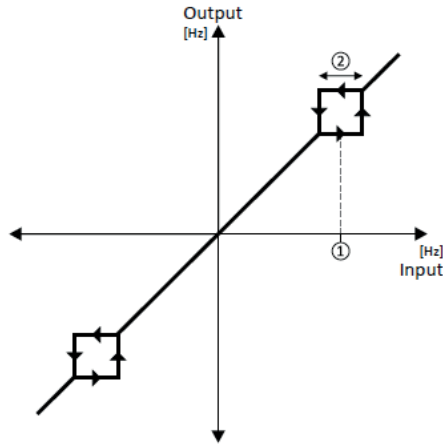

Example: For a blocking zone, the frequency is set to 20 Hz and the bandwidth to 10 Hz.

These settings mask out the range from 15 Hz to 25 Hz.

Notes:

- Skip frequencies are absolute values. With the setting "20 Hz", at the same time also the skip frequency "-20 Hz" is defined.
- The VSD accelerates/decelerates the motor by the range to be masked out. A continuous operation within this range is not possible.
- A blocking zone is not active if its bandwidth is set to "0 Hz".

Adjacent and overlapping ranges:

- Example on the left: If the ranges are closely spaced, the ranges are passed through as shown.
- Example on the right: If the ranges overlap, the lowest and highest value form a new range.

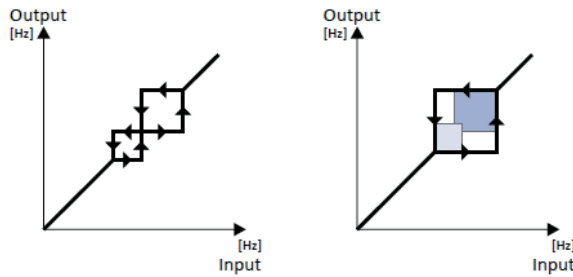

Valid and invalid ranges:

- Example on the left: Skip frequency = 5 Hz, bandwidth = 10 Hz → Valid range (starts at ≥ 0)
- Example on the right: Skip frequency = 4 Hz, bandwidth = 10 Hz → Invalid range (starts at < 0); is thus ignored.

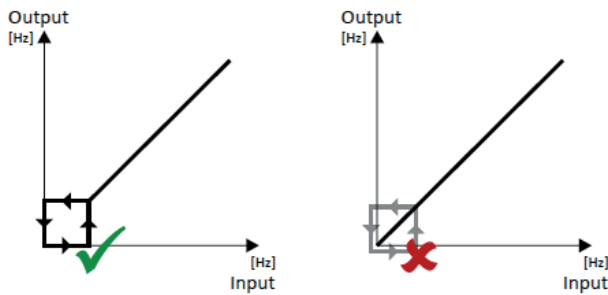

P317:1	0x291F:1	Skip frequency 1
0.0 ... [0.0] ... 599.0 Hz		Centre of frequency range 1 which is to be skipped.
P317:2	0x291F:2	Skip bandwidth 1
0.0 ... [0.0] ... 10.0 Hz		Size of frequency range 1 which is to be skipped.
P317:3	0x291F:3	Skip frequency 2
0.0 ... [0.0] ... 599.0 Hz		Centre of frequency range 2 which is to be skipped.
P317:4	0x291F:4	Skip bandwidth 2
0.0 ... [0.0] ... 10.0 Hz		Size of frequency range 2 which is to be skipped.
P317:5	0x291F:5	Skip frequency 3
0.0 ... [0.0] ... 599.0 Hz		Centre of frequency range 3 which is to be skipped.
P317:6	0x291F:6	Skip bandwidth 3
0.0 ... [0.0] ... 10.0 Hz		Size of frequency range 3 which is to be skipped.

5.5.3.3 Optimising the stalling behaviour

If the motor is driven with frequencies above the rated motor frequency, the operating point is shifted to the "field weakening range". In this range, the motor voltage does not increase proportionately to the output frequency anymore. As a consequence, the VSD automatically reduces the maximum current since the full torque is not available anymore at these frequencies. For special motors which enable an operation in the field weakening range, the behaviour in the field weakening range can be adapted to the motor with P319:0.

DANGER!

Danger by incorrect parameterisation.
Possible consequences: damage to material assets and injury to persons

➔ Only change the default setting (0 Hz) in P319:0 after consulting the motor manufacturer!

➔ Recommendation: Maintain default setting (0 Hz).

Preconditions

The function is only effective in the following motor control types:

- V/f characteristic control (VFC open loop)
- V/f characteristic control (VFC closed loop)

Details

The operating range of an asynchronous motor consists of the voltage range ① and the field weakening range. The field weakening range again is divided into two ranges:

- In the first range ②, the power can be kept constant without the motor stalling.
- The second field weakening range ③ is characterized by the fact that the maximum permissible stator current is decreased to prevent the motor from stalling.

Speed/torque curve of the asynchronous motor with two field weakening ranges

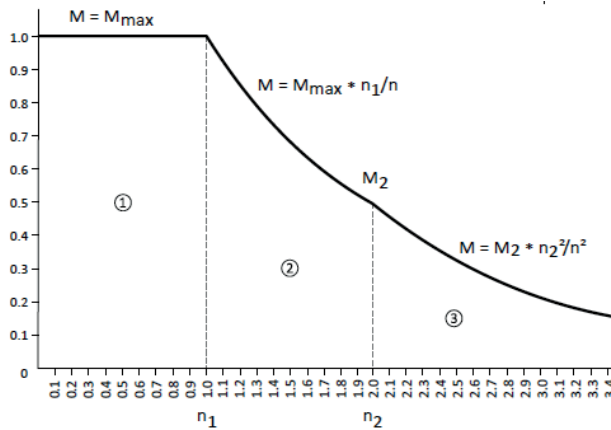

The override point (n2, M2) can be influenced with P319:0.

P319:0 > 0 Hz:

- The maximum current characteristic is shifted to higher field frequencies by the frequency entered.
- The maximum permissible current and the maximum torque increase in the field weakening range.
- The risk of motor stalling increases.

P319:0 < 0 Hz:

- The maximum current characteristic is shifted to lower field frequencies by the frequency entered.
- The maximum permissible current and the maximum torque are reduced in the field weakening range.
- The risk of motor stalling is reduced.

P319:0	0x2B0C	Override field weakening
-599.0 ... [0.0] ... 599.0 Hz		Offset of the override point for field weakening.

5.5.3.4 Slip compensation

In case of a load, the speed of an asynchronous motor decreases. This load-dependent speed drop is called slip. The slip compensation serves to counteract the load-dependent speed loss.

Preconditions

The function is only effective in the motor control type "V/f characteristic control (VFC open loop)".

In order that the function can determine the rated slip correctly, the following parameters must be set correctly:

- Rated speed
- Rated frequency
- Number of pole pairs (automatically calculated from Rated speed and Rated frequency)

Details

The slip compensation increases or decreases the output frequency as a response to a load change. Thus, the slip is counteracted and the speed is kept precisely.

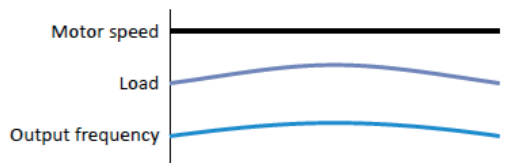

The rated slip required for the slip compensation is calculated by the VSD according to the following formula:

$$\text{Rated slip [\%]} = (1 - (\text{rated motor speed [rpm]} / (120 * \text{rated motor frequency [Hz]} / \text{number of poles}))) * 100$$

Calculation example:

- Rated motor speed = 1750 rpm
- Rated motor frequency = 60 Hz
- Number of poles = 2 * Number of pole pairs = 2 * 2 = 4
- Rated slip = $(1 - (1750 / (120 * 60 / 4))) * 100 = 2.77 \%$

The rated slip represents the reduction of the motor speed due to the motor load. At full speed and full load, the motor given in the example would rotate with 1750 rpm, which means 2.77 % below its synchronous speed of 1800 rpm. In order to compensate this speed loss, the VSD increases the output frequency by the rated slip multiplied by the rated motor frequency. In the example $2.77 \% * 60 \text{ Hz} = 1.66 \text{ Hz}$ increase at full load.

In order to consider load changes, the influence of the rated slip on output frequency can be adapted in P315:1. A setting of 100 % corresponds to the rated slip of the machine in the nominal operating point.

With reference to the example above and a setpoint frequency of 60 Hz:

- P315:1 = 100 %, the output frequency is = 61.66 Hz (60 Hz + 100 % * 1.66 Hz).
- P315:1 = 50 %, the output frequency is = 60.83 Hz (60 Hz + 50 % * 1.66 Hz).

Additionally, the filter time for the slip compensation can be adapted in P315:2 if required. The preset filter time is adapted to typical motors. If full load or nearly full load oscillations or instabilities occur, we recommend an increase of the filter time.

P315:1	0x2B09:1	Slip compensation: Gain
-200.00 ... [100.00] ... 200.00 %		Adjustment in percent of the slip calculated. - For instance required for deviations of the real motor data from the nameplate data. - A setting of 100 % corresponds to the rated slip of the machine in the nominal operating point.
P315:2	0x2B09:2	Slip compensation: Filter time
1 ... [5] ... 6000 ms		Filter time for the slip compensation. - The preset filter time is adapted to typical motors.
P351:4	0x2C02:4	Slip frequency
Read only: x.x Hz		Display of the rated slip determined.

5.5.3.5 Oscillation damping

The oscillation damping serves to reduce the oscillations during no-load operation which are caused by energy oscillating between the mechanical system (mass inertia) and the electrical system (DC bus). Furthermore, the oscillation damping can also be used to compensate for resonances.

Preconditions

The function is only effective in the following motor control types:

- V/f characteristic control (VFC open loop)
- V/f characteristic control (VFC closed loop)

Restrictions

Observe the following restrictions:

- Damping is possible only for constant oscillations at a steady-state operating point.
- Oscillations occurring sporadically cannot be damped.
- Oscillation damping is not suitable for oscillations occurring during dynamic processes (e.g. accelerations or load changes).
- Oscillation damping is only active if the setpoint speed is greater than 10 rpm and the DC bus voltage exceeds a value of 100 V.

Details

The determination of the oscillation is based on the active current. In order to obtain the alternating component of the active current, this current is differentiated. This signal is then passed through a PT1 filter.

Identification of the oscillation

Before the oscillation damping function can be parameterised, the oscillation has to be identified.

One way to do this is to examine the motor current while oscillation damping is switched off (gain = 0 %). At steady-state operation, a constant current flows. If the drive oscillates, these oscillations are also visible on the motor current. It is therefore possible to determine the frequency and the amplitude of the oscillation from the alternating component of the motor current. In the following, this alternating component is referred to as "current oscillation".

Parameter setting

The gain of the oscillation signal is to be set according to the following equation:

$$P318:1 = \text{current amplitude} * 100 \% / (\sqrt{2} * \text{maximum device current})$$

The default time constant of the PT1 filter should be sufficient for most applications. If required, it is only possible to adapt the time constant via VLBSW01

Generally, the time constant must be set so that the oscillation can be dampened, but that higher-frequency components are filtered from the signal. The time constant is determined from the reciprocal value of the double current oscillation frequency:

$$P318:2 = 1 / (2 * \text{oscillation frequency})$$

P318:1	0x2B0A:1	Gain
-100 ... [20] ... 100 %		Gain of the oscillation signal. • With the setting 0, oscillation damping is deactivated.
P318:2	0x2B0A:2	Filter time
1 ... [5] ... 600 ms		Time constant of the PT1 filter.

5.5.4 OPTIMISATION OF THE CONTROL LOOPS

If there is a need to improve the total power of the system, different options are available:

- a) Tuning of the motor and the speed controller
 - b) Automatic motor identification (energized)
 - c) Automatic motor calibration (non-energized)
- Simply select an option that best suits your environment and requirements!

5.5.4.1 Options for optimized motor tuning

The option to be selected depends on the respective application. Depending on the selected option, different procedures become active and thus different parameter groups are influenced:

- Rated motor data
- VSD characteristic
- Motor equivalent circuit diagram data
- Motor controller settings
- Speed controller settings.

5.5.4.1.1 Tuning of the motor and the speed controller

The following describes in general how to optimise the speed controller. This may be required if some parameters have on the load side of the drive system have changed or have not been set yet, such as:

- Motor moment of inertia
- Load moment of inertia
- Type of coupling between moment of inertia of the motor and that of the load.

Preconditions

- All rated motor data are known and set in the VSD (see chapter "motor data").
- All further options for optimisation have been executed before if possible.
 - Automatic motor identification (energized)
 - Automatic motor calibration (non-energized)
- Optimisation is possible online or offline (with or without connected motor).

Required steps

Adapt the following parameters to your drive system using the engineering tool. Since this only changes load-dependent data, the other parameter groups must not be calculated again.

P335:1	0x2910:1	Motor moment of inertia
0.00 ... [Type code dependent] ... 20000000.00 kg cm ²		Setting of the moment of inertia of the motor.
P335:2	0x2910:2	Load moment of inertia
0.00 ... [Type code dependent] ... 20000000.00 kg cm ²		Setting of the moment of inertia of the load. - Always adjust the setting to the current load, otherwise the optimization process cannot be executed successfully.
-	0x2910:3	Coupling
0: Stiff 1: Elastic 2: With backlash		Selection of the type of coupling between the moment of inertia of the motor and that of the load.
-	0x2904	Actual speed filter time
0.0 ... [2.0] ... 50.0 ms		Filter time for the actual speed value.

5.5.4.1.2 Automatic motor identification (energized)

The automatic identification of the motor results in the best possible parameter settings. If the application enables you to energise the system during the optimisation, carry out this optimisation.

Preconditions

- The motor must be cold.
- All rated motor data are known and set in the VSD.
- In P300:0 the motor control type required and suitable for the motor is selected.
- In P301:0 the operating mode "MS: Velocity mode [-2]" or "CiA: Velocity mode [2]" is set.
- DC-bus voltage is available.
- The VSD is error-free and in the "Ready to switch on" or "Switched on" device state.
- The motor is stopped (no start enable).
- No VSD disable is active.
- No quick stop is active.
- No other axis command is active anymore.

General information on the identification

- The automatic identification can take from some seconds to minutes.
- The procedure can be aborted any time by VSD disable or cancellation of the start enable without settings being changed.
- During and after the procedure, the LED "RDY" (blue) is permanently on.
- After completing, a renewed start command is required to start the motor.

Required steps

Set P327:4 = "1".

Issue the start command to start the procedure.

P327:4	0x2822:4	Identify motor data (energized)
0 ... [0] ... 1		1 = start automatic identification of the motor data. - VSD characteristics, motor equivalent circuit diagram data and controller settings are identified and set automatically. - During the procedure, the motor is energised!

Optimisation process

As soon as the process has been started, the following steps are initiated:

1. The VSD characteristic is automatically identified by the VSD.
2. The motor equivalent circuit diagram data are automatically identified by the VSD.
3. The motor controller settings are automatically calculated.
4. The speed controller settings are automatically calculated

5.5.4.1.3 Automatic motor calibration (non-energized)

If the application does not enable you to energise the system during the optimisation, carry out this optimisation.

Preconditions

- All rated motor data are known and set in the VSD.
- In P300:0 the motor control type required and suitable for the motor is selected.
- The VSD is error-free and in the "Ready to switch on" or "Switched on" device state.
- The VSD is disabled or the motor is stopped (no start enable).
- No other axis command is active anymore.

Required steps

Set P327:5 = "1" to start the process.

P327:5	0x2822:5	Calibrate motor data (non-energized)
0 ... [0] ... 1		1 = start automatic calibration of the motor data. - A default VSD characteristic is loaded. - The motor equivalent circuit diagram data and controller settings are calculated on the basis of the currently set rated motor data. - The motor is not energised.

Optimisation process

As soon as the process has been started, the following steps are initiated:

1. A default VSD characteristic is loaded.
2. The motor equivalent circuit diagram data is calculated based on the currently set rated motor data.
3. The motor controller settings are automatically calculated.
4. The speed controller settings are automatically calculated.

5.5.4.2 Motor equivalent circuit diagram data

The motor equivalent circuit diagram data are automatically set if one of the following optimizations is carried out:

- Automatic motor identification (energized)
- Automatic motor calibration (non-energized).

-	0x2C01:2	Motor parameters: Stator resistance
0.0000 ... [Type Code dependent] ... 125.0000 Ω		Stator resistance General motor data. Carry out settings as specified by manufacturer data/motor data sheet.
-	0x2C01:3	Stator leakage inductance
0.000 ... [Type Code dependent] ... 500.000 mH		Stator leakage inductance General motor data. Carry out settings as specified by manufacturer data/motor data sheet.
P351:1	0x2C02:1	Motor parameter (ASM): Rotor resistance
0.0000 ... [Type Code dependent] ... 200.0000 Ω		Rotor resistance Equivalent circuit data of the motor required for the motor model.
P351:2	0x2C02:2	Motor parameter (ASM): Mutual inductance
0.0 ... [Type Code dependent] ... 50000.0 mH		Mutual inductance Equivalent circuit data of the motor required for the motor model.
P351:3	0x2C02:3	Motor parameter (ASM): Magnetising current
0.00 ... [Type Code dependent] ... 500.00 A		Magnetising current Equivalent circuit data of the motor required for the motor model.

5.5.4.3 Motor controller settings

After the motor settings have been made, the different control loops must be set. For a quick commissioning, the calculations and settings are made automatically if one of the following optimisations is carried out:

- Automatic motor identification (energized)
- Automatic motor calibration (non-energized)

Details

The following controllers have an influence in the respective motor control type:

Function	Motor control type				
	VFC open loop	VFC closed loop	SC-ASM	SL-PSM	SLVC
Current controller	●	●	●	●	●
Field controller			●		●
Field weakening controller			●		●
Imax controller	●	●			
Flying restart controller	●			●	●
SLVC controller					●
Slip controller		●			

VFC open loop = V/f characteristic control
 VFC closed loop = V/f characteristic control with speed feedback
 SC-ASM = servo control for asynchronous motor
 SL-PSM = sensorless control for synchronous motor
 SLVC = sensorless vector control

5.5.4.3.1 Current controller

For a quick commissioning, the calculations and settings are made automatically during the optimisation.

- i** For typical applications, a manual adaptation of the parameters of the current controller is not recommended. A wrong setting may have a negative effect on the control. For special applications, contact the manufacturer before adapting the parameters.

Preconditions

The current controller parameters are calculated based on the stator resistance and leakage inductance. Thus, the following parameters must be set correctly, either via optimisation or manually (according to manufacturer-data/motor data sheet):

- 0x2C01:2: Stator resistance
- 0x2C01:3: Stator leakage inductance

P334:1	0x2942:1	Current controller parameters: Gain
0.00 ... [Type code dependent] ... 750.00 V/A		Gain factor Vp of the current controller.
P334:2	0x2942:2	Current controller parameters: Reset time
0.01 ... [Type code dependent] ... 2000.00 ms		Reset time Ti of the current controller.

5.5.4.3.2 Field controller

For a quick commissioning, the calculations and settings are made automatically during the optimisation.

The field controller is only effective in the following motor control types:

- Servo control (SC ASM)
- Sensorless vector control (SLVC)

For the manual adaptation of the parameters refer to the software VLBXSW01.

5.5.4.3.3 Field weakening controller

For a quick commissioning, the calculations and settings are made automatically during the optimisation.

The field controller is only effective in the following motor control types:

- Servo control (SC ASM)
- Sensorless vector control (SLVC)

For the manual adaptation of the parameters refer to the software VLBXSW01.

5.5.4.3.4 I_{max} controller

For a quick commissioning, the calculations and settings are made automatically during the optimisation.

I For typical applications, a manual adaptation of the parameters of the I_{max} controller is not recommended. A wrong setting may have a negative effect on the control.
For special applications, contact the manufacturer before adapting the parameters.

The I_{max} controller is only effective in the following motor control types:

- V/f characteristic control (VFC open loop)
- V/f characteristic control (VFC closed loop)

Details

The I_{max} controller becomes active in the V/f operation if the actual motor current exceeds the maximum overload current "Max current". The I_{max} controller changes the output frequency to counteract the exceedance.

The maximum overload current "Max current" is defined in P324:0 in percent with regard to the rated motor current "Motor rated current" (P323:0).

If the maximum overload current is exceeded:

- During operation in motor mode, the I_{max} controller reduces the output frequency.
- During operation in generator mode, the I_{max} controller increases the output frequency.

Setting notes

If oscillations occur at the current limit during operation:

- Reduce gain of the I_{max} controller in P333:1.
- Increase reset time of the I_{max} controller in P333:2.
- Carry out the changes in small steps only (by 2 ... 3 % of the set value) until the oscillations do not exist anymore.

If the I_{max} controller does not respond fast enough after the maximum current has been exceeded:

- Increase gain of the I_{max} controller in P333:1.
- Reduce reset time of the I_{max} controller in P333:2.
- Carry out the changes in small steps only (by 2 ... 3 % of the set value) until the response time is acceptable.

-	0x2822:19	Calculate I _{max} controller parameter
0 ... [0] ... 1		1 = start automatic calculation of the I _{max} controller parameters. - Gain (P333:1) and reset time (P333:2) of the I _{max} controller are recalculated and set.
P333:1	0x2B08:1	V/f I _{max} controller: Gain
0.000 ... [Type Code dependent] ... 1000.000 Hz/A		Gain factor V _p of the I _{max} controller.
P333:2	0x2B08:2	V/f I _{max} controller: Reset time
1.0 ... [Type Code dependent] ... 2000.0 ms		Reset time T _i of the I _{max} controller.

5.5.4.3.5 Flying restart controller

For a quick commissioning, the calculations and settings are made automatically during the optimisation.

The flying restart controller is only effective in the following motor control types:

- V/f characteristic control (VFC open loop)
- Sensorless control (SL PSM)
- Sensorless vector control (SLVC)

Details

See parameter P718:3.

This parameter is only relevant for the flying restart circuit if an asynchronous motor is controlled. In case of a sensorless control of a synchronous motor (SL-PSM) the parameter has no meaning.

5.5.4.3.6 SLVC controller

For a quick commissioning, the calculations and settings are made automatically during the optimisation.

The SLVC controller is only effective in the motor control type "Sensorless vector control (SLVC)".

For the manual adaptation of the parameters refer to the software VLBXSW01.

5.5.4.3.7 Slip controller

In case of V/f characteristic control with feedback (P300:0 = "V/f characteristic control (VFC closed loop) [7]"), the slip is calculated and injected by the slip controller. The default setting of the slip controller provides robustness and moderate dynamics.

- The slip controller is designed as PI controller.
 - In order to improve the response to setpoint changes, the setpoint speed of setpoint frequency is added as feedforward control value to the output (correcting variable) of the slip controller.
- For more information refer to the software VLBXSW01.

5.5.4.4 Speed controller

The speed controller is automatically set if one of the following optimisations is carried out:

- Automatic motor identification (energized)
- Automatic motor calibration (non-energized).

i For typical applications, a manual adaptation of the parameters of the speed controller is not recommended. A wrong setting may have a negative effect on the control. For special applications, contact the manufacturer before adapting the parameters.

The speed controller has an influence in the following motor control types:

- Servo control (SC ASM)
- Sensorless control (SL PSM)
- Sensorless vector control (SLVC)

The automatically calculated settings for the speed controller enable an optimal control behaviour for typical load requirements:

- Minimum speed loss ①
- Minimum settling time ②
- Minimum overshoot ③

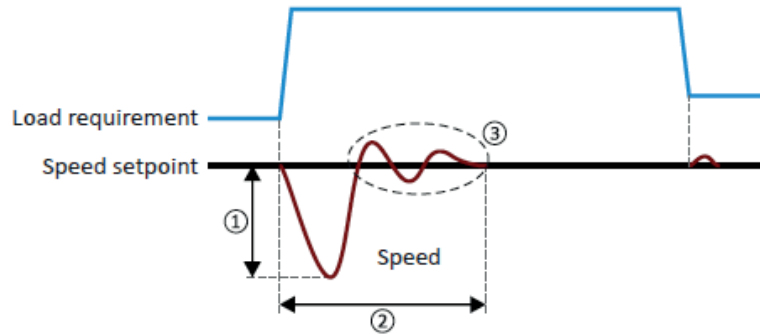

Setting notes

If oscillations occur during operation after high load requirements:

- Reduce gain of the speed controller in P332:1.
- Increase reset time of the speed controller in P332:2.

If the speed loss is too high or the settling time too long during operation with high load requirements:

- Increase gain of the speed controller in P332:1.

Note. If the gain is set too high or the reset time too low, the speed control loop can become unstable!

P332:1	0x2900:1	Speed controller settings: Gain
0.00000 ... [Type code dependent] ... 20000.00000 Nm/rpm		Gain factor V_p of the speed controller.
P332:2	0x2900:2	Speed controller settings: Reset time
1.0 ... [Type code dependent] ... 6000.0 ms		Reset time T_i of the speed controller.

5.5.5 CONFIGURING THE TORQUE CONTROL

In general, the VSD is operated in a mode that controls the motor frequency. Alternatively, the VSD can be configured in such a way that it controls a motor torque within a defined frequency range. Typical applications for such a torque control with frequency limitation are winders and packaging machines.

Torque control is available on VSD with firmware ≥ 4.1 .

A torque control is only possible in the motor control type P300:0 = "Sensorless vector control (SLVC) [4]".

After configuring the sensorless vector control (SLVC), one of the following optimisations must be carried out for a torque control as precise as possible:

- Automatic motor identification (energized)
- Automatic motor calibration (non-energized)

Details

Setpoint selection:

- Instead of a frequency setpoint in [Hz], a torque setpoint has to be defined for the torque control. This can be either a value in percent with reference to the rated motor torque set in P325:0 or a value in [Nm] if defined via network.
- The standard setpoint source for the torque control can be selected in P201:3 (default: Analog input 1).

Limitation of the torque range:

- The positive and negative torque limit can be set independently of each other.

Frequency limitation / speed limitation:

- The adjustable speed limits serve to protect against very high speeds. High speeds can occur if a pure torque is selected without a counter torque being available (load-free machine).
- The torque control controls the assigned torque setpoint within the set speed limits. The actual speed results from the load conditions of the application. If the actual speed reaches the set speed limits, it is kept on the respective limit value. This protective function is also called "speed limitation".
- The lower and upper speed limit for speed limitation can be set independently of each other. They can also be defined via analog inputs or network.

In the following, the steps required for configuring the torque control with frequency limitation are described.

Parameterisation required

1. Set the operating mode "MS: Torque mode [-1]" in P301:0.
2. Set the rated motor torque in P325:0.
3. Set the permissible maximum torque in P326:0.
 - The setting is made in percent with reference to the rated motor torque set in P325:0.
4. Select the source for the positive torque limit in P337:1.
 - Default setting: Maximum torque P326:0
 - In case of selection "Analog Input 1 [2]": Set setting range in P430:11 and P430:12.
 - In case of selection "Analog Input 2 [3]": Set setting range in P431:11 and P431:12.
 - In case of selection "Positive torque limit [4]": Set the positive torque limit in 0x60E0.
5. Select the source for the negative torque limit in P337:2.
 - Default setting: (-) Maximum torque P326:0.
 - In case of selection "Analog Input 1 [2]": Set setting range in P430:11 and P430:12.
 - In case of selection "Analog Input 2 [3]": Set setting range in P431:11 and P431:12.
 - In case of selection "Negative torque limit [4]": Set the negative torque limit in 0x60E1.
6. Select the source for the upper speed limit in P340:3.
 - Default setting: Maximum frequency P211:0.
 - In case of selection "Analog Input 1 [2]": Set setting range in P430:2 and P430:3.
 - In case of selection "Analog Input 2 [3]": Set setting range in P431:2 and P431:3.
 - In case of selection "Upper speed limit [Hz] [4]": Set the upper speed limit in [Hz] in P340:5.
 - In case of selection "Upper speed limit [5]": Set the upper speed limit in [vel. unit] in P340:1.
7. Select the source for the lower speed limit in P340:4.
 - Default setting: (-) Maximum frequency P211:0.
 - In case of selection "Analog input 1 [2]": Set setting range P430:2 and P430:3.
 - In case of selection "Analog input 2 [3]": Set setting range in P431:2 and P431:3.
 - In case of selection "Lower frequency limit [4]": Set the lower speed limit in [Hz] in P340:6.
 - In case of selection "Lower speed limit [5]": Set the lower speed limit in [vel. unit] in P340:2.
8. Select the standard setpoint source for the torque control in P201:3.
 - Default setting: Analog input 1. In case of this selection, set the setting range in P430:11 and P430:12.
 - In case of selection "Analog input 2 [3]": Set the setting range in P431:11 and P431:12.
 - Except for the network, the torque setpoint must be given in percent with regard to the P325:0 rated motor torque.
 - Via network the torque setpoint is selected via the mappable parameter P592:8 in [Nm / 2 scaling factor]. The scaling factor can be set in P592:9.
9. Optionally: For a "smooth" change-over between different setpoint sources, adapt the ramp time for the torque setpoint in P336:2.

The torque control with frequency limitation is now active and the VSD responds to the torque setpoint given by the selected setpoint source.

P340:1	0x2946:1	Speed limitation: Upper speed limit
-480000 ... [0] ... 480000 vel. unit		Upper limit for the speed limitation. – Setting is only effective with the selection "Upper speed limit [5]" in P340:3. Note – Entry via keypad is in rpm! – Via RPDO the unit is vel. unit and the scaling must be taken into account. – $\pm 480000 \text{ rpm} = \pm 2^{31} [\text{n-unit}]$
P340:2	0x2946:2	Speed limitation: Lower speed limit
-480000 ... [0] ... 480000 vel. unit		Lower limit for speed limitation. – Setting is only effective with the selection "Lower speed limit [5]" in P340:4. Note – Entry via keypad is in rpm! – Via RPDO the unit is vel. unit and the scaling must be taken into account. – $\pm 480000 \text{ rpm} = \pm 2^{31} [\text{n-unit}]$
P340:3	0x2946:3	Speed limitation: Upper speed limit source
0: Maximum frequency 1: Fixed Limit 0.0 Hz 2: Analog input 1 3: Analog input 2 4: Upper frequency limit 5: Upper speed limit 6: Network target velocity		Selection of the source for the upper speed limit. 0: Maximum frequency Upper speed limit = Maximum frequency P211:0. 1: Fixed Limit 0.0 Hz Upper speed limit = 0.0Hz. 2: Analog input 1 The upper speed limit is defined as analog signal via the analog input 1. 3: Analog input 2 The upper speed limit is defined as analog signal via the analog input 2. 4: Upper frequency limit Upper speed limit = setting in P340:5 in [Hz]. 5: Upper speed limit Upper speed limit = setting in P340:1 in [vel. unit]. 6: Network target velocity The upper speed limit is defined as process data object via network.

P340:4	0x2946:4	Speed limitation: Lower speed limit source
0: (-) Maximum frequency 1: Fixed Limit 0.0 Hz 2: Analog input 1 3: Analog input 2 4: Lower frequency limit 5: Lower speed limit 6: Network target velocity		Selection of the source for the upper speed limit. 0: (-) Maximum frequency Lower speed limit = (-) Maximum frequency P211:0. 1: Fixed Limit 0.0 Hz Lower speed limit = 0.0Hz. 2: Analog input 1 The lower speed limit is defined as analog signal via the analog input 1. 3: Analog input 2 The lower speed limit is defined as analog signal via the analog input 2. 4: Lower frequency limit Lower speed limit = setting in P340:6 in [Hz]. 5: Lower speed limit Lower speed limit = setting in P340:2 in [vel. unit]. 6: Network target velocity The upper speed limit is defined as process data object via network.
P340:5	0x2946:5	Speed limitation: Upper frequency limit
-1000.0 ... [50.0] ... 1000.0 Hz		Upper limit for the speed limitation.
P340:6	0x2946:6	Speed limitation: Lower frequency limit
-1000.0 ... [50.0] ... 1000.0 Hz		Lower limit for speed limitation.
P340:7	0x2946:7	Speed limitation: Actual upper speed limit
Read only [Hz]		Display of the current upper limit for speed limitation.
P340:8	0x2946:8	Speed limitation: Actual lower speed limit
Read only [Hz]		Display of the current lower limit for speed limitation.
P336:2	0x2948:2	Ramp time
0.0 ... [1.0] ... 60.0 s		Ramp time for operating mode "MS: Torque mode". – The torque setpoint is led via a ramp generator. This provides for a "smooth" switch-over between different setpoint sources. – The set ramp time refers to the ramping up/down of 0 ... 100 % rated motor torque P325:0. At a lower setpoint selection, the ramp time is reduced accordingly.
P337:1	0x2949:1	Positive torque limit source
0: Max torque 1: Fixed Limit 0.0 Hz 2: Analog input 1 3: Analog input 2 4: Positive torque limit 5: Network target torque		Selection of the source for the positive torque limit source. 0: Max torque Positive torque limit source = Max torque P326:0. 1: Fixed Limit 0.0 Hz Positive torque limit source = 0.0 %. 2: Analog input 1 The positive torque limit source is defined as analog signal via the analog input 1. 3: Analog input 2 The positive torque limit source is defined as analog signal via the analog input 2. 4: Positive torque limit Positive torque limit source = Positive torque limit 0x60E0. 5: Network target torque The positive torque limit source is defined as process data object via network.
P337:2	0x2949:2	Negative torque limit source
0: (-) Max torque 1: Fixed Limit 0.0 Hz 2: Analog input 1 3: Analog input 2 4: Negative torque limit 5: Network target torque		Selection of the source for the negative torque limit source. 0: (-) Max torque Negative torque limit source = (-) Max torque P326:0. 1: Fixed Limit 0.0 Hz Negative torque limit source = 0.0 %. 2: Analog input 1 The negative torque limit source is defined as analog signal via the analog input 1. 3: Analog input 2 The negative torque limit source is defined as analog signal via the analog input 2. 4: Negative torque limit Negative torque limit source = Negative torque limit 0x60E1. 5: Network target torque The negative torque limit source is defined as process data object via network.
P337:3	0x2949:3	Actual positive torque limit
Read only: x.x %		Display of the current positive torque limit. – 100 % ≡ Motor rated torque (P325:0).
P337:4	0x2949:4	Actual negative torque limit
Read only: x.x %		Display of the current negative torque limit. – 100 % ≡ Motor rated torque (P325:0).
-	0x2DD5	Torque setpoint
Read only: x.xx Nm		Display of the current torque setpoint.

See also parameters P452:1 ... P452:8 (Torque setpoint presets).

5.5.6 ROTATION RESTRICTION

The rotation of the motor can be restricted to forward only.

P304:0	0x283A:0	Rotation restriction			
0: Forward only 1: Forward and reverse		The VSD can be limited to Forward (FWD) rotation only. This affects the final output setpoint for velocity and PID setpoint Note: This command only prevents negative velocity setpoints. Therefore it is still possible that the motor runs reverse (Example: Wrong wiring).			

5.5.7 SWITCHING FREQUENCY

The VSD output is DC voltage that is sine-coded pulse width modulated (PWM) to approximate variable frequency AC voltage. The frequency of the PWM pulses is adjustable. This adjustment is called the PWM switching frequency.

General:

- Higher switching frequencies will result in less audible noise but will cause the VSD to generate more heat and operate less efficiently.
- Lower switching frequencies will result in more audible noise but will cause decreased earth leakage current, increased VSD efficiency and increased ambient operating temperature range.

P305:0	0x2939:0	Switching frequency			
1: 4kHz var. / optimized 2: 8kHz var. / optimized 3: 16kHz var. / optimized 5: 2kHz fix / optimized 6: 4kHz fix / optimized 7: 8kHz fix / optimized 8: 16kHz fix / optimized 11: 4kHz var. / min. Pv 12: 8kHz var. / min. Pv 13: 16kHz var. / min. Pv 15: 2kHz fix / min. Pv 16: 4kHz fix / min. Pv 17: 8kHz fix / min. Pv 18: 16kHz fix / min. Pv 21: 8kHz var./opt./4kHz min. 22: 16kHz var./opt./4kHz min. 23: 16kHz var./opt./8kHz min 31: 8kHz var./ Pv/4kHz min. 32: 16kHz var./ Pv/4kHz min. 33: 16kHz var./ Pv/8kHz min.		Definition of the Switching Frequency 1, 2, 3: Optimized for best VSD performance (symmetrical modulation) Variable switching frequency: VSD reduces the switching frequency if output current or VSD temperature are too high. Minimal Switching Frequency is limited to 2 kHz. 5, 6, 7, 8: Optimized for best VSD performance (symmetrical modulation) Switching frequency is fixed. 11, 12, 13: Optimized for best VSD efficiency (asymmetrical modulation). Variable switching frequency: VSD reduces the switching frequency if output current or VSD temperature are too high. Minimal Switching Frequency is limited to 2 kHz. 15, 16, 17, 18: Optimized for best VSD efficiency (asymmetrical modulation). Switching frequency is fixed. 21, 22, 23: Optimized for best VSD performance (symmetrical modulation) Variable switching frequency: VSD reduces the switching frequency if output current or VSD temperature are too high. Minimal Switching Frequency is limited to 4 kHz or 8 kHz. 31, 32, 33: Optimized for best VSD efficiency (asymmetrical modulation). Variable switching frequency: VSD reduces the switching frequency if output current or VSD temperature are too high. Minimal Switching Frequency is limited to 4 kHz or 8 kHz.			

5.5.8 MOTOR PROTECTION

Many monitoring functions integrated in the VFD can detect errors and thus protect the device or motor from being destroyed or overloaded.

5.5.8.1 Motor overload monitoring ($I^2 \cdot t$)

This function monitors the thermal utilisation of the motor, taking the motor currents recorded and a mathematical model as a basis.

DANGER!

Fire hazard by overheating of the motor.

Possible consequences: Death or severe injuries

- ▶ To achieve full motor protection, an additional temperature monitoring function with a separate evaluation must be installed.
- ▶ When actuating motors that are equipped with PTC thermistors or thermal contacts, always activate the PTC input.

Details

This function only serves to functionally protect the motor. It is not suitable for the safety-relevant protection against energy-induced hazards, since the implementation is not fail-safe.

- When the thermal motor utilisation calculated reaches the threshold set in P308:1, the response set in P308:3 is triggered.
- With the setting P308:3 = "No response [0]", the monitoring function is deactivated.

i For a UL-compliant operation, leave P308:2 and P308:3 to the default setting!
(speed compensation = "on [0]" and error response = "Fault [3]")
In order to meet the UL requirements, the calculated motor load is internally saved when the VFD is switched off and loaded again when the VFD is switched on.

i If a suitable motor temperature sensor is connected to the terminals X109/T1 and X109/T2 and the response to the triggering of the motor temperature monitoring in P309:2 is set to "Fault [3]", the response of the motor overload monitoring may be set other than "Fault [3]" in P308:3.

The following two diagrams show the relation between the motor load and release time of the monitoring under the following conditions:

- Maximum utilisation P308:1 = 150 %
- Speed compensation P308:2 = "Off [1]" or output frequency ≥ 40 Hz

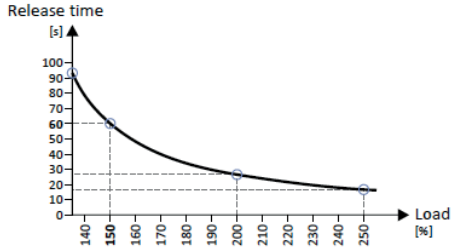
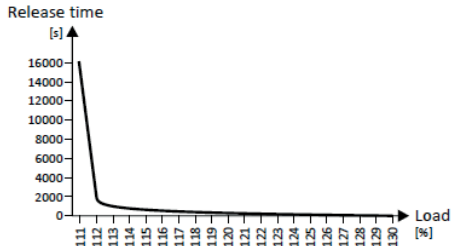

Load * Load ratio	Release time
110%	Indefinite
135%	93s
150%	60s
200%	26s
250%	17s

Depending on the setting in P308:1, the release time from the diagrams can be derived as follows:

- Calculation of the load ratio:
Load ratio = 150 % / maximum utilisation P308:1.
(example: P308:1 = 75 % \rightarrow load ratio = 150 % / 75 % = 2)
- Calculation of the release time of the monitoring:
Release time = actual load * load ratio
(example: actual load = 75 % \rightarrow release time = 75 % * 2 = 150 %)
- Looking up the release time from the above table based on load * load ratio.
(example: Load * load ratio = 150 % \rightarrow release time = 60 s)

Speed compensation for protecting motors at low speed

The VFD comes with an implemented compensation for low speed. If the motor is driven with frequencies lower than 40 Hz, the speed compensation in P308:2 should be set to "On [0]" (default setting). This setting serves to reduce the release time of the monitoring at low speed to consider the reduced natural ventilation at AC motors. The speed compensation for UL-compliant operation in P308:2 must be set to "On [0]" as well.

If the speed compensation is activated, the release time is reduced as follows:

- With an output frequency < 40 Hz: Reduced release time to $62.5 \% + 37.5 \% * \text{output frequency [Hz]} / 40$ [Hz]
- With an output frequency ≥ 40 Hz: No reduced release time

The following diagram shows the reduced release time with activated speed compensation.

- Maximum utilisation P308:1 = 150 %
- Speed compensation P308:2 = "On [0]"

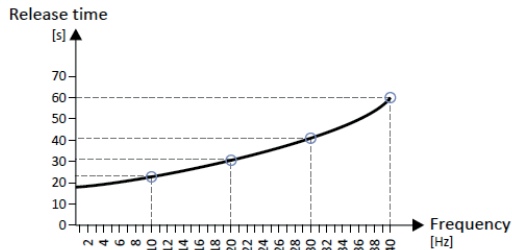

Output frequency	Release time
40Hz	60s
30Hz	≈ 41 s
20Hz	≈ 31 s
10Hz	≈ 23 s

The following diagram shows the possible permanent load with activated speed compensation without the monitoring being triggered.

- Maximum utilisation P308:1 = 150 %
- Speed compensation P308:2 = "On [0]"

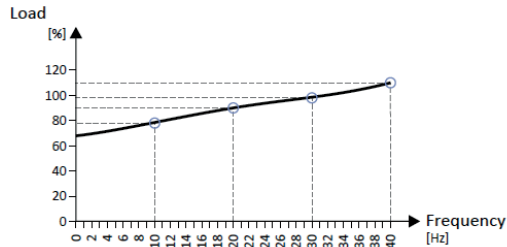

Output frequency	Possible permanent load
40Hz	110%
30Hz	99%
20Hz	90%
10Hz	79%

In case of 0 Hz, only a load of 62.7 % (= 62.5 %) with regard to the load at 40 Hz or above is possible ($69 / 110 * 100 \% = 62.7 \%$). In case of a deviating setting in P308:1, the maximum possible motor load changes proportionately.

P308:1	0x2D4B:1	Motor overload monitoring (i^{2*t}): Maximum utilization [60 s]			
30 ... [150] ... 200 %		Maximum permissible thermal motor utilisation (max. permissible motor current for 60 seconds). – 100 % \equiv rated motor current P323:0. – If the motor is actuated with the current set here for 60 seconds, the maximum permissible thermal motor utilisation is reached and the response set in P308:3 is executed. – If the motor is actuated with a different current, the time period until the motor overload monitoring function is activated is different. Generally the following applies: the lower the current, the lower the thermal utilisation and the later the monitoring function is triggered.			
P308:2	0x2D4B:2	Motor overload monitoring (i^{2*t}): Speed compensation			
0: On 1: Off		Use this function to protect motors that are actuated at a speed below 40 Hz. – UL-compliant operation requires the setting "On [0]!" 0: On Release time for motor overload monitoring is reduced in order to compensate for the reduced cooling of naturally ventilated AC induction motors during operation at low speed. 1: Off Function deactivated, no reduction of the motor overload monitoring release time.			
P308:3	0x2D4B:3	Motor overload monitoring (i^{2*t}): Response			
3: Fault (Reference see P310:1)		Selection of the response to the triggering of motor overload monitoring. – UL-compliant operation requires the setting "Error [3]!" Associated error code: – 9040 0x2350 - CiA: i^{2*t} overload (thermal state)			

5.5.8.2 Motor temperature monitoring

In order to record and monitor the motor temperature, a PTC thermistor (single sensor according to DIN 44081 or triple sensor according to DIN 44082) or thermal contact (NC contact) can be connected to the terminals T1 and T2. This measure helps to prevent the motor from being destroyed by overheating.

Preconditions

- The VSD can only evaluate one PTC thermistor!
- Do not connect several PTC thermistors in series or parallel.
- If several motors are actuated on one VFD, thermal contacts (NC contacts) connected in series are to be used.
- To achieve full motor protection, an additional temperature monitoring function with a separate evaluation must be installed.
- By default, a wire jumper is installed between terminals X109/T1 and X109/T2, which must be removed when the PTC thermistor or thermal contact is connected.

Details

If $1.6 \text{ k}\Omega < R < 4 \text{ k}\Omega$ at terminals X109/T1 and X109/T2, the monitoring function will be activated; see functional test below.

- If the monitoring function is activated, the response set in P309:2 will be effected.
- The setting P309:2 = 0 deactivates the monitoring function.

i If a suitable motor temperature sensor is connected to the terminals X109/T1 and X109/T2 and the response in P309:2 is set to "Fault [3]", the response of the motor overload monitoring may be set other than "Fault [3]" in P308:3.

Functional test

Connect a fixed resistor to the PTC input:

- $R > 4 \text{ k}\Omega$: the monitoring function must be activated.
- $R < 1 \text{ k}\Omega$: the monitoring function must not be activated.

P309:2	0x2D49:2	Motor temperature monitoring: Response			
3: Fault (Reference see P310:1)		Selection of the response to the triggering of the motor temperature monitoring. Associated error code: – 17168 0x4310 - Motor temperature error			

5.5.8.3 Maximum overload current of the VSD

For the purpose of current limitation, a maximum overload current can be set for the VFD.

If the current consumption of the motor exceeds this current limit, the VFD changes its dynamic behaviour, in order to counteract this exceedance.

- The maximum overload current of the VFD can be set in P324:0.
- Reference for the percentage setting of the maximum overload current is the rated motor current set in P323:0.
- The actual motor current is displayed P104:0.

P324:0	0x6073	Max current			
0.0 ... [200.0] ... 3000.0 %		Maximum overload current of the VFD. 100 % \equiv Motor rated current P323:0.			

5.5.8.4 Overcurrent monitoring

This function monitors the instantaneous value of the motor current and serves as motor protection.

i With an incorrect parameterisation, the maximum permissible motor current may be exceeded in the process.
Possible consequence: irreversible damage of the motor.

- ▶ The setting of the threshold for the overcurrent monitoring in P353:1 must be adapted to the connected motor.
- ▶ Set the maximum output current of the VFD in P324:0 much lower than the threshold for overcurrent monitoring.

P353:1	0x2D46:1	Overcurrent monitoring: Threshold			
0.0 ... [Type code dependet]... 1000.0 A		Warning/error threshold for motor current monitoring. If the instantaneous value of the motor current exceeds the threshold set, the response set in P353:2 is effected for the purpose of motor protection. The parameter is calculated and set in the course of the automatic identification of the motor.			
P353:2	0x2D46:2	Overcurrent monitoring: Response			
3: Fault (Reference see P310:1)		Selection of the response to the triggering of motor current monitoring. Associated error code: 29056 0x7180 - Motor overcurrent			

5.5.8.5 Motor phase failure detection

The motor phase failure detection function can be activated for both synchronous and asynchronous motors.

Phase failure detection during operation is basically only suitable for applications which are operated with a constant load and speed. In all other cases, transient processes or unfavourable operating points can cause maloperation.

If a current-carrying motor phase (U, V, W) fails during operation, the response selected in P310:1 is tripped if the following two conditions are met:

- Condition 1: detection is activated. See P310:2.
- Condition 2: a specific commutation angle (approx. 150° electrically) has been covered without the detection of a current flow.

P310:1	0x2D45:1	Motor phase failure detection: Response
0: No response 1: Warning 2: Trouble 3: Fault		Selection of the response following the detection of a motor phase failure. Associated error codes: – 65289 0xFF09 - Motor phase missing – 65290 0xFF0A - Motor phase failure phase U – 65291 0xFF0B - Motor phase failure phase V – 65292 0xFF0C - Motor phase failure phase W
P310:2	0x2D45:2	Motor phase failure detection: Current threshold
1.0 ... [5.0] ... 25.0 %		Current threshold for the activation of the motor phase failure detection function. – 100 % ≡ Maximum current 0x2DDF:002 – Background: in order to be able to reliably detect the failure of a motor phase, first a certain must flow for the current sensor system. The detection function is therefore only activated if the actual value of the motor current has exceeded the current threshold set here. – Display of the present motor current in P104:0.
P310:3	0x2D45:3	Motor phase failure detection: Voltage threshold
0.0 ... [10.0] ... 100.0 V		Voltage threshold for the monitoring of several motor phases. – The V/f characteristic control enables the detection of several failed motor phases during operation. – Monitoring with regard to the failure of several motor phases is active if a response that is not "0: No response" is set in P310:1 and if the motor voltage exceeds the voltage threshold set here. – The monitoring function is triggered if the level of the motor current is lower than the device-dependent threshold for longer than 20 ms. – The monitoring function for the failure of several motor phases can be deactivated if the value "100.0 V" is set here.

5.5.8.6 Motor speed monitoring

This function monitors the motor speed during operation.

In order to detect the current motor speed, the VFD must be enabled and the motor must rotate.

For an exact monitoring, rated motor speed P320:4 and rated motor frequency P320:5 must be set correctly.

If the motor speed reaches the threshold set in P350:1, the response set in P350:2 takes place.

P350:1	0x2D44:1	Overspeed monitoring: Threshold
50 ... [8000] ... 50000 rpm		Warning/error threshold for motor speed monitoring. – If the motor speed reaches the threshold set, the response selected in P350:2 is effected. – The parameter is calculated and set in the course of the automatic identification of the motor.
P350:2	0x2D44:2	Overspeed monitoring: Response
3: Fault (Reference see P310:1)		Selection of the response to the triggering of motor speed monitoring. Associated error code: 65286 0xFF06 - Motor overspeed

5.5.8.7 Motor torque monitoring

The motor torque monitoring can only be used for the following motor control types with speed controller:

- Servo control (SC ASM)
- Sensorless control (SL PSM)
- Sensorless vector control (SLVC)

This function sets the internal status signal "Torque limit reached [79]" = TRUE if the maximum possible torque has been reached.

The status signal is set irrespective of the response P329:1 and delay time P329:2 set for this monitoring.

P329:1	0x2D67:1	Maximum torque monitoring: Response
0: No response. For further possible settings, see P310:1.		Selection of response to reaching the maximum possible torque. The selected response takes place if the status signal "Torque limit reached [79]" = TRUE and the deceleration time set in P329:2 has elapsed. Associated error code: 33553 0x8311 - Torque limit reached
P329:2	0x2D67:2	Maximum torque monitoring: Triggering delay
0.000 ... [0.000] ... 10.000 s		Optional setting of a deceleration for triggering the response selected in P329:1. Typical application: – The motor should be driven at the torque limit for a short time without triggering the selected response. – Only after a longer operation (> set deceleration) at the torque limit, the selected response is to take place.
P326:0	0x6072	Max torque
0.0 ... [250.0] ... 3000.0 %		Symmetrical selection of the maximum permissible torque. – 100 % ≡ Motor rated torque (P325:0) – This parameter serves to implement a statically and bipolarly acting torque limitation. This can be used, for instance, as overload protection of the mechanical transmission path/elements starting at the motor shaft. – This limitation acts irrespective of the torque limitations acting in unipolar mode that are set in 0x60E0 and x60E1.

5.5.9 ENCODER SETTINGS

In general, an encoder is a measuring system which serves to detect the velocity/speed and possibly the position of a kinematics or motor.

The VLB3 exclusively supports HTL encoders.

5.5.9.1 HTL encoder

In case of the VLB3, the digital inputs DI3 and DI4 can be configured as HTL input to evaluate the signal of a cost-effective HTL encoder or a reference frequency ("pulse train").

An HTL encoder can be used at the VLB3 for the following tasks:

- As motor encoder for a motor speed feedback for speed control as precise as possible.
- As setpoint encoder for defining a frequency setpoint.
- As setpoint encoder for defining the reference value for the process controller.
- As setpoint encoder for defining a torque setpoint.
- As actual value encoder for the process controller.
- As actual value encoder for the "position counter" function.

Preconditions

- Single-track or two-track HTL encoder.
 - A single-track HTL encoder (track A) cannot be used for motor speed feedback.
 - A two-track HTL encoder (track A and B) must have a phase offset of exactly 90° between track A and B (error ≤ ±10°). VFD tracks are not required.
 - Encoder increments: ≤ 16384 increments per revolution
 - For supplying the encoder, the maximum supply current of the VFD must be considered.
- If necessary, an external 24V voltage supply for the encoder is required.

Restrictions

- When the digital inputs DI3 and DI4 are configured as HTL input, these two digital inputs are no longer available for other control functions.
- The HTL input can be either used for detecting an HTL encoder signal or a pulse train. They cannot be used at the same time.
- The maximum input frequency of the digital inputs is 100 kHz. If this frequency is exceeded, an error is triggered.

Connections

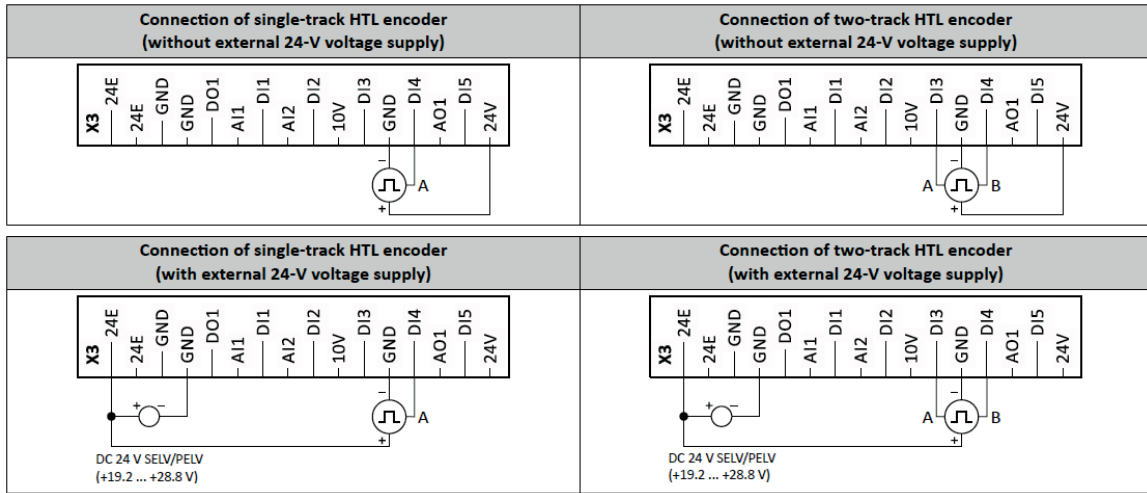

Details

Encoder dimensioning: Calculate maximum number of increments per revolution of the encoder	
Max. encoder increments = $f_{max} [Hz] * 60s / n_{max} [rpm]$	
Max encoder increment = $100000 [Hz] * 60s / 1500 [rpm] = 4000$ increments/revolution	
f_{max}	Maximum input frequency of the digital inputs = 100kHz = 100000Hz
n_{max}	Maximum encoder speed (in this example: 1500 rpm)
Max encoder increments	Maximum number of increments per encoder revolution

i Select an encoder with a maximum number of increments per revolution which is lower than or equal to the calculated number. The higher the number of increments per revolution, the more stable the system is.

- Setup:
1. Set the selection "HTL encoder (AB) [1]" in P410:2 to configure the digital inputs DI3 and DI4 as encoder inputs.
 2. Set the encoder increment/revolution P341:1 according to the manufacturer data/encoder data sheet.
 3. Select the function of the encoder:
P600:2 Feedback PID / P201:2 PID setpoint / P201:1 Frequency setpoint
- Note: If SC or SLPSM mode is selected the encoder is automatically assigned as feedback.
The actual encoder feedback is displayed in 0x2C42:6

P341:1	0x2C42:1	Encoder settings: Increments/revolution
1 ... [128] ... 16384		Encoder increment. Carry out setting according to manufacturer data/encoder data sheet.
P410:2	0x2630:2	Settings for digital inputs: Input function
0: Digital input 1: HTL encoder (AB) 2: Pulse train 3: Pulse train/direction		Input function of the digital terminals DI3 and DI4. 0: Digital input DI3 = digital input DI4 = digital input 1: HTL encoder (AB) DI3 = HTL input for encoder track B DI4 = HTL input for encoder track A 2: Pulse train – available from version 4.1 DI3 = digital input DI4 = HTL input for pulse train 3: Pulse train/direction – available from version 4.1 DI3 = HTL input for direction specification; HIGH level = counter-clockwise (CCW) DI4 = HTL input for pulse train
-	0x2C42:6	Encoder settings: Actual velocity
Read only: x rpm		Display of the speed currently detected by the encoder.

5.5.9.2 Encoder monitoring

For monitoring the HTL encoder, two monitoring functions are implemented in the VFD firmware:

- a) Encoder signal loss monitoring: Is triggered if a failure of the encoder signal is detected (e. g. due to open circuit or failure of the encoder current supply).
- b) Encoder maximum frequency monitoring: Is triggered if the calculated encoder maximum frequency is beyond the permissible frequency range of the digital inputs.

Preconditions

- The encoder signal loss monitoring is only active if the HTL encoder
 - Is set as feedback system for the motor control or
 - Used as signal source for the "Position counter" function.
- For the encoder signal loss monitoring, the VSD must be enabled and the motor must rotate.
- The encoder maximum frequency monitoring is active as soon as the HTL encoder has been configured.

Restrictions

- The encoder signal loss monitoring does not work anymore if the "DC braking" function is active.
- The response time of the encoder signal loss monitoring depends on the setting of the encoder increments/revolution in P341:1.
- The settings of the speed controller can influence the encoder signal loss monitoring. If the reset time of the speed controller is very low or deactivated, an encoder signal loss cannot be detected at switch-on.
- If the HTL encoder is used as signal source for the "Position counter" function, an encoder signal loss cannot be detected at switch-on.
- Combined with the "Holding brake control" function:
 - In order that the encoder signal loss monitoring is not triggered by mistake, monitoring will only be activated when the holding brake is released.
 - If Brake closing time P712:2 and Brake opening time P712:3 are not set correctly, the encoder signal loss monitoring can be triggered although an encoder signal is available.

Details on encoder signal loss monitoring

The encoder signal loss monitoring distinguishes between the following signal failures:

- a) Complete failure (no encoder signals available at all, e. g. in case the encoder current supply has failed)
- b) Only one track has failed (track A or track B)

In order to detect a complete failure, the VFD calculates internally two trigger thresholds for monitoring based on the configuration of the HTL encoder:

1. Based on the encoder resolution set in P341:1, the minimum output frequency is calculated:

$$\text{Minimum output frequency [Hz]} = \frac{\text{number of motor pole pairs}}{t_{\max} [\text{s}] \cdot \frac{\text{encoder increments}}{\text{edge}} \cdot \text{revolution}} = \frac{\text{number of motor pole pairs}}{0.001 [\text{s}] \cdot 4 \cdot \frac{\text{encoder increments}}{\text{revolution}}}$$

Note: The maximum time (tmax) per edge is 0.001 s. In order to prevent a false tripping, this value is multiplied by the factor 4.

Calculation example:

Number of pole pairs = 2

Encoder resolution = 128 increments/revolution

$$\text{minimum output frequency [Hz]} = \frac{2}{0.001 [\text{s}] \cdot 4 \cdot 128} = 3.9 [\text{Hz}]$$

2. The maximum permitted time is calculated in which a new signal edge of the encoder must arrive:

$$\text{time per edge [s]} = \frac{1}{\text{encoder frequency [Hz]} \cdot \frac{\text{encoder increments}}{\text{revolution}}}$$

If the calculation with the (synchronous) encoder frequency at minimum output frequency (here: 2 * 3.9 Hz) is carried out, the resulting time interval equals the maximum time per edge (here: 0.001s)

If the real encoder frequency is lower than the calculated minimum output frequency AND if the new signal edge has not arrived within the maximum permitted item, monitoring is triggered. The complete failure is displayed via the status bit 4 in 0x2C42:7.

If only track A or B fails, signals are continued to be detected. In this case, however, the sign of the frequency changes with every new signal edge. In order to detect the failure of only one track, an internal counter is increased by 1 every time the sign between two signal edges changes. If the sign is unchanged in two signal edges in a row, the counter is reset. If the counter reaches the counter content "100", monitoring is triggered. The failure of only one track is displayed via the status bit 5 in 0x2C42:7.

Both in case of a complete failure and in case only one track fails, the error message "Encoder open circuit" (error code 29445 | 0x7305) is output. The error response can be selected in P342:0.

Details on encoder maximum frequency monitoring

After the HTL encoder has been configured (or if the encoder settings are changed), the VFD internally calculates the maximum possible number of encoder pulses per second (hereinafter referred to as "encoder maximum frequency"):

$$\text{encoder maximum frequency [Hz]} = \frac{\text{encoder increments}}{\text{revolution}} \cdot \frac{\text{max. motor speed [rpm]}}{60}$$

If the calculated encoder maximum frequency is beyond the permissible frequency range of the digital inputs, monitoring is triggered:

- The status bit 0 in 0x2C42:7 is set to "1".
- The warning "Feedback system: speed limit" (error code 29573 | 0x7385) is output.

Calculation example 1:

- Maximum input frequency of the digital inputs = 100 kHz
- Encoder resolution P341:1 = 1024 increments/revolution
- Max motor speed P322:0 = 3000 rpm

$$\text{encoder maximum frequency [Hz]} = 1024 \frac{\text{encoder increments}}{\text{revolution}} \cdot \frac{3000 \text{ [rpm]}}{60} = 51200 \text{ [Hz]}$$

Result: The encoder maximum frequency monitoring is not triggered because the encoder maximum frequency is within the permissible frequency range of the digital inputs.

Calculation example 2:

- Maximum input frequency of the digital inputs = 100 kHz
- Encoder resolution P341:1 = 4096 increments/revolution
- Max motor speed P322:0 = 3600 rpm

$$\text{encoder maximum frequency [Hz]} = 4096 \frac{\text{encoder increments}}{\text{revolution}} \cdot \frac{3600 \text{ [rpm]}}{60} = 245760 \text{ [Hz]}$$

Result: the encoder maximum frequency monitoring is triggered because the encoder maximum frequency is beyond the permissible frequency range of the digital inputs.

P342:0	0x2C45	Encoder-error response
0: No response 1: Warning 3: Fault		Selection of the response to the triggering of the encoder signal loss monitoring. Associated error code: 29445 0x7305 - Encoder open circuit
-	0x2C42:7	Encoder settings: Status
0 ... [0] ... 4294967295 Bit 0 : Maximum encoder speed reached Bit 4: No signal detected Bit 5: Encoder track A or B missing		Bit coded display of the status of encoder monitoring. Bit 0 = "1" means that the calculated encoder maximum frequency is beyond permissible frequency range of digital inputs. Bit 4 = "1" means that complete failure of the encoder signals has been detected. Bit 5 = "1" means that a failure of only one track (A or B) has been detected,

5.5.10 Dual rating

The VLB3 has two different load characteristics: "Light Duty" and "Heavy Duty".

The load characteristic "Light Duty" enables a higher output current with restrictions regarding overload capacity, ambient temperature and switching frequency. As a result, the motor can be driven by a less powerful variable speed drive. The selected load characteristic depends on the application.

NOTE

This function is available from firmware 5.1 and only for power sizes >= 4kW.

NOTE

Load characteristic "Light Duty"

In order to avoid irreversible damage to the VSD/motor:

- ▶ Based on the configuration document, check whether the VSD can be operated with the load characteristic "Light Duty".
- ▶ Comply with all data in the configuration document for this load characteristic and the corresponding mains voltage range. Among other things, this includes information on the type of installation and required fuses, cable cross-sections, mains chokes and filters.
- ▶ Set the parameters only in accordance with the following specifications .

Details

The following table compares the two load characteristics:

	Duty selection P306:1	
	"Heavy Duty [0]"	"Light Duty [1]"
Characteristics	High dynamic requirements	Low dynamic requirements
Typical applications	Main tool drives, travelling drives, hoist drives, winders, forming drives and conveyors.	Pumps, fans, general horizontal materials handling technology, line drives and centrifugal pumps.
Overload capacity	200% for 3s, 150% for 60s For details see instruction I472.	Reduced overload For details see instruction I472.

i If the VLB3 is reset to the default setting, the load characteristic is set to "Heavy Duty [0]".

Parameters

P306:1	0x2D43:1	VSD load characteristic: Duty selection
0: Heavy Duty (heavy load) 1: Light Duty (standard load)		Selection of the load characteristic. Further required settings: - Set the data of the motor used. - Set application-specific parameters such as current limits 0: Heavy Duty Load characteristic for high dynamic requirements. 1: Light Duty Load characteristic for low dynamic requirements. - The device overload monitoring (i*t) is adapted.

5.6 GROUP 4 – I/O SETUP

5.6.1 FUNCTION LIST (RUN/STOP/START/JOG/REVERSE)

Parameters P400:1...P400:49 contain the main functions of the VSD. The function can be assigned to a trigger. If the trigger is activated the function is executed. The digital trigger values can come from external sources (Digital Inputs, Network, etc.) and internal sources (VSD status, faults, etc.) It is possible to assign more than one function to a single trigger.

Basic functionalities:

- VSD enable
Enables the VSD. Signal must have the state TRUE (by Input or setting) to be able to start the motor.
- Run/Stop
Enables the running of the motor. Can be used as single signal or in combination with the signals Start Forward / Start Reverse. Signal must have the state TRUE (by Input or setting) to be able to start the motor.
- Start Forward / Start Reverse
Used to start the motor (Positive edge triggered). Stop is down with the Run/Stop signal.
- Run Forward / Run Reverse
Used to run and stop the motor (Maintained signals)
- Rotation inversion
Inverts the speed setpoint
- JOG Forward / JOG Reverse
JOG the motor with a fixed speed. Jog has higher priority than Run/Stop, Start or Run commands.
- Fault Reset
For a successful reset of a fault it is necessary to correct the condition that caused the fault first. Afterwards there are different possibilities to reset the fault:

Function to reset fault:	Parameter	Transition
Reset fault	P400:4	FALSE > TRUE (Rising edge)
VSD enable	P400:1	TRUE > FALSE (Falling Edge)
Run/Stop	P400:2	TRUE > FALSE (Falling Edge)
Keypad STOP	-	FALSE > TRUE (Rising edge)

➔ See chapter "5.2 Flexible I/O configuration"

i In Flexible Control mode (P200:0) either VSD enable (P400:1) or Run/Stop (P400:2) must be assigned to I/O to ensure that the drive can always be stopped!
(Exception: VSD is controlled from network, Network enable (P400:37) is HIGH)

i NOTICE!

The JOG functions have priority over Stop commands. If the VSD is currently JOGGING, pressing the STOP key on the keypad or triggering STOP command will NOT stop the motor!

P400:1	0x2631:1	VSD enable			
0: Not connected 1: Constant TRUE 11: Digital input 1 12: Digital input 2 13: Digital input 3 14: Digital input 4 15: Digital input 5 50: Running 51: Ready to run 53: Stop active 54: Quick stop active 58: Device warning 59: Device fault active 60: Heatsink temp. warning 69: Rotation inverted 70: Frequency threshold exceeded 71: Actual speed = 0 78: Current threshold exceeded 79: Maximum torque 81: Error analog input 1 82: Error analog input 2 83: Loss of load 102: Sequence suspended 103: Sequence done 104: Local control active 105: Remote control active 106: Manual setpoint active 107: Automatic setpoint active	State: TRUE enables the VSD. FALSE inhibits the VSD and the motor will coast stop. Note: Signal must have the state TRUE (by Input or setting) to be able to start the motor				
P400:2	0x2631:2	Run/Stop			
11: Digital input 1 (Reference see P400:1)	VSD Run/Stop signal	State: TRUE will make the VSD ready to run FALSE will stop the motor according to the defined stop method Note: Set 01 TRUE to disable the function Signal must have the state TRUE (by Input or setting) to be able to start the motor			
P400:3	0x2631:3	Quick stop			
0: Not connected (Reference see P400:1)	The quick stop function works as pause or zero speed function. If the quick stop is applied the motor will ramp down with the defined QSP ramp. Note: 0: FALSE disables this functionality				

P400:4	0x2631:4	Reset fault			
12:Digital input 2 (Reference see P400:1)		Trigger for fault reset FALSE->TRUE transition the faults will be reset.			
P400:5	0x2631:5	DC braking			
0: Not connected (Reference see P400:1)		Trigger = TRUE: Activate DC braking Trigger = FALSE: Deactivate DC braking			
P400:6	0x2631:6	Start forward (CW)			
0:Not connected (Reference see P400:1)		Start forward signal (Edge triggered) State: Transition FALSE-->TRUE will start the motor forward Note: – Use P400:2 “Run/Stop” signal to stop the motor – Set the signal to 0: FALSE to disable the function – If a bipolar input (-10V..+10V) is used the direction is controlled by the reference signal			
P400:7	0x2631:7	Start reverse (CCW)			
0:Not connected (Reference see P400:1)		Start reverse signal (Edge triggered) State: Transition FALSE-->TRUE will start the motor backward Note: – Use P400:2 “Run/Stop” signal to stop the motor – Set the signal to 0: FALSE to disable the function – If a bipolar input (-10V..+10V) is used the direction is controlled by the reference signal			
P400:8	0x2631:8	Run forward (CW)			
0:Not connected (Reference see P400:1)		Run forward signal (Maintained signal) State: TRUE will start the motor forward The last activated signal of run forward and run reverse defines the direction! FALSE of Run Forward and Run Reverse will stop the motor according to the defined stop method Note: – Set the signal to 0: FALSE to disable the function – If a bipolar input (-10V..+10V) is used the direction is controlled by the reference signal			
P400:9	0x2631:9	Run reverse (CCW)			
0:Not connected (Reference see P400:1)		Run reverse signal (Maintained signal) State: TRUE will start the motor reverse The last activated Signal of Run Forward and Run Reverse defines the direction! FALSE of Run Forward and Run Reverse will stop the motor according to the defined stop method Note: – Set the signal to 0: FALSE to disable the function – If a bipolar input (-10V..+10V) is used the direction is controlled by the reference signal			
P400:10	0x2631:10	Jog forward (CW)			
0:Not connected (Reference see P400:1)		JOG Forward with preset frequency 5 State: TRUE will start the motor forward with preset frequency 5 FALSE will stop the motor If JOG forward and JOG reverse are applied at the same time the motor will stop and the JOG has to be retriggered! WARNING: The JOG functions have priority over Stop commands. If the VSD is currently JOGGING, pressing the STOP key on the keypad or triggering STOP command will NOT stop the motor!			
P400:11	0x2631:11	Jog reverse (CCW)			
0:Not connected (Reference see P400:1)		JOG Forward with preset frequency 6 State: TRUE will start the motor reverse with preset frequency 6 FALSE will stop the motor If JOG forward and JOG reverse are applied at the same time the motor will stop and the JOG has to be retriggered! WARNING: The JOG functions have priority over Stop commands. If the VSD is currently JOGGING, pressing the STOP key on the keypad or triggering STOP command will NOT stop the motor!			
P400:12	0x2631:12	Keypad control			
0:Not connected (Reference see P400:1)		Keypad Selection for Start/Stop command State: TRUE: Start and Stop commands coming from the keypad FALSE: Start and Stop commands are defined by the connection list			
P400:13	0x2631:13	Invert rotation			
13:Digital input 3 (Reference see P400:1)		Rotation inversion signal State: TRUE: target reference setpoint is inverted (i.e. times -1) FALSE: the target reference setpoint in not inverted			

5.6.2 SETPOINT SELECTION

Since only one setpoint source can be active at a time, the following priorities apply:

Flexible I/O configuration or keypad control active P400:37 = FALSE	Network control active P400:17 = FALSE P400:37 = TRUE
Prio 1: Functions for setpoint change-over The priority of the functions results from the assigned triggers (in the order of the selection list): 1. Constant TRUE [1] 2. Digital input 1 [11] 3. Digital input 2 [12] 4. Digital input 3 [13] 5. ... Prio 2: Set standard setpoint source – P201:1: Frequency control: Default setpoint source – P201:2: PID control: Default setpoint source – P201:3: Torque control: Default setpoint source	Prio 1: Setpoint source selected via network control word. Prio 2: Set standard setpoint source – P201:1: Frequency control: Default setpoint source. – P201:2: PID control: Default setpoint source. – P201:3: Torque control. Default setpoint source.

Example of allocating priority

Parameter	Name	Setting
P400:14	Activate AI1 setpoint	Digital input 5 [15]
P400:16	Activate keypad setpoint	Digital input 4 [14]

Digital input 4	Digital input 5	Active setpoint source
FALSE	FALSE	Standard setpoint source set in P201:1
FALSE	TRUE	Analog input 1
TRUE	FALSE	Keypad
TRUE	TRUE	Keypad (since "Digital input 4" trigger is higher in the selection list than "Digital input 5" trigger)

P400:14	0x2631:14	AI1 setpoint selection			
0: Not connected (Reference see P400:1)		Selects Analog input 1 as setpoint source			
P400:15	0x2631:15	AI2 setpoint selection			
0: Not connected (Reference see P400:1)		Selects Analog input 2 as setpoint source			
P400:16	0x2631:16	Keypad setpoint selection			
0: Not connected (Reference see P400:1)		Selects Keypad as setpoint source			
P400:17	0x2631:17	Setpoint = Network			
0: Not connected 116: Netw.Ref active (Other Reference see P400:1)		Selects Network as setpoint source. Note: In Network mode (P400:37 = TRUE) the triggers P400:14 – P400:25 are not active. To select the network as setpoint source in network mode (P400:37 = TRUE) use the "Default setpoint source" (P201:1-2) or the corresponding control bits (AC Drive Control Word, C135 Control Word, NET-WordIN1). 116: TRUE if AC Drive Control Word (0x400B:1) bit 6 is active			
P400:18	0x2631:18	Preset selection bit 0			
14: Digital input 4 (Reference see P400:1)		Preset frequency setpoint selection bit 0 Combination Example: bit0 and bit2 result in preset frequency 5			
P400:19	0x2631:19	Preset selection bit 1			
15: Digital input 5 (Reference see P400:1)		Preset frequency setpoint selection bit 1			
P400:20	0x2631:20	Preset selection bit 2			
0: Not connected (Reference see P400:1)		Preset frequency setpoint selection bit 2			
P400:21	0x2631:21	Preset selection bit 3			
0: Not connected (Reference see P400:1)		Preset frequency setpoint selection bit 3			

5.6.2.1 Changing the setpoint source during operation: examples

Example 1: Change-over from keypad setpoint to AI1/AI2 setpoint

- The keypad is set as standard setpoint source.
- The switch S1 starts the motor in the forward direction of rotation. The switch S1 in the initial position stops the motor again.
- The switch S2 switches the direction of rotation.
- The switch S3 activates analogue input 1 as setpoint source.
- The switch S4 activates analogue input 2 as setpoint source.

i If S3 and S4 are actuated at the same time, the analogue input 1 is active as setpoint source since the digital input 3 assigned to this function has a higher priority than the digital input 4.

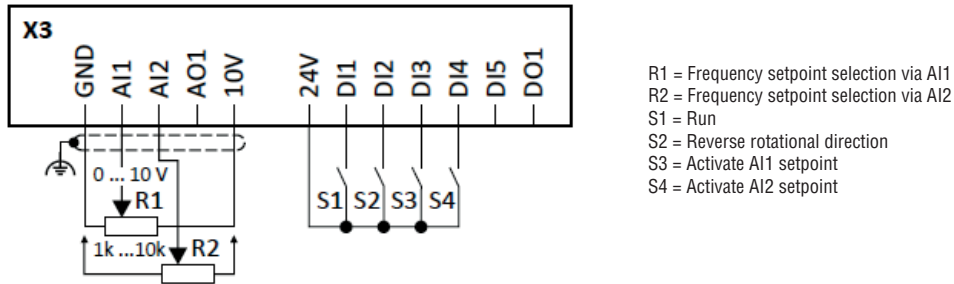

Parameter	Name	Setting
P400:1	Enable VSD	Constant TRUE [1]
P400:2	Run	Digital input 1 [11]
P400:4	Reset fault	Not connected [0]
P400:13	Reverse rotational direction	Digital input 2 [12]
P400:14	Activate AI1 setpoint	Digital input 3 [13]
P400:15	Activate AI2 setpoint	Digital input 4 [14]
P400:18	Activate preset (bit 0)	Not connected [0]
P200:0	Control selection	Flexible I/O configuration [0]
P203:3	Stop method	Standard ramp [1]
P201:1	Frequency control: Default setpoint source	Keypad [1]

Input signals

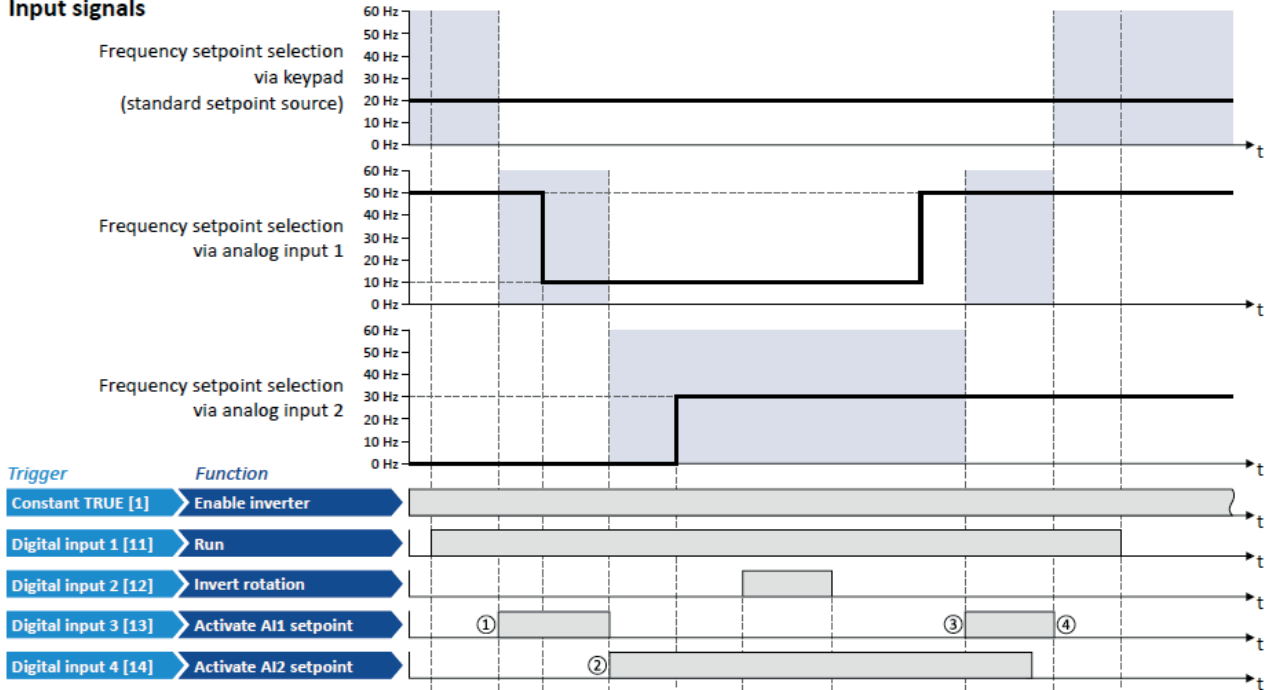

Output signals

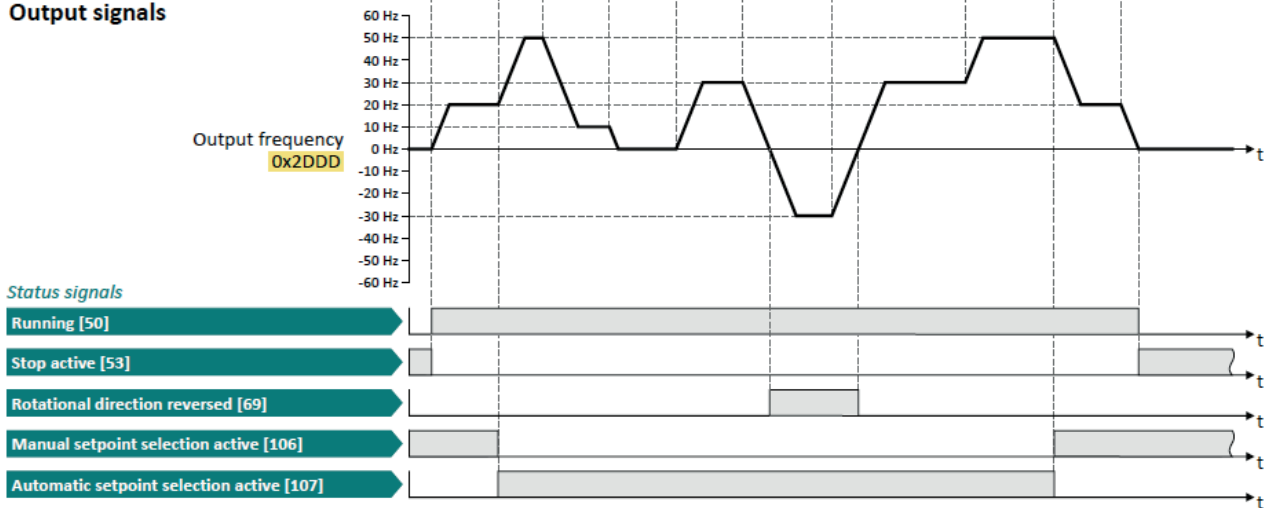

The status signals can be assigned to digital outputs.

- ① The change-over is initiated from keypad setpoint (standard setpoint source) to AI1 setpoint.
- ② The change-over is initiated from AI1 setpoint to AI2 setpoint.
- ③ The change-over is initiated from AI2 setpoint to AI1 setpoint since the digital input 3 has a higher priority than the digital input 4.
- ④ The change-over is initiated to keypad setpoint (standard setpoint source).

Example 2: Change-over from AI1 setpoint to keypad setpoint

- The analog input 1 is set as standard setpoint source.
- Switch S1 starts the motor in forward direction of rotation. Switch S2 in the initial position stops the motor again.
- Switch S2 switches the direction of rotation.
- Switch S3 activates the keypad as setpoint source. The keypad setpoint can be changed in the operating mode via the arrow navigation keys.

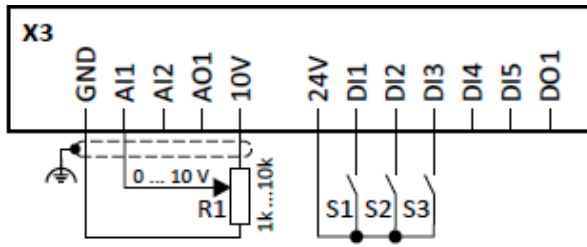

R1 = Frequency setpoint selection
S1 = Run
S2 = Reverse rotational direction
S3 = Activate keypad setpoint

Parameter	Name	Setting
P202:1	Keypad setpoints: Frequency setpoint	20.0 Hz
P400:1	Enable VSD	Constant TRUE [1]
P400:2	Run	Digital input 1 [11]
P400:4	Reset fault	Not connected [0]
P400:13	Reverse rotational direction	Digital input 2 [12]
P400:16	Activate keypad setpoint	Digital input 3 [13]
P200:0	Control selection	Flexible I/O configuration [0]
P203:3	Stop method	Standard ramp [1]
P201:1	Frequency control: Default setpoint source	Analog input 1 [2]

Input signals

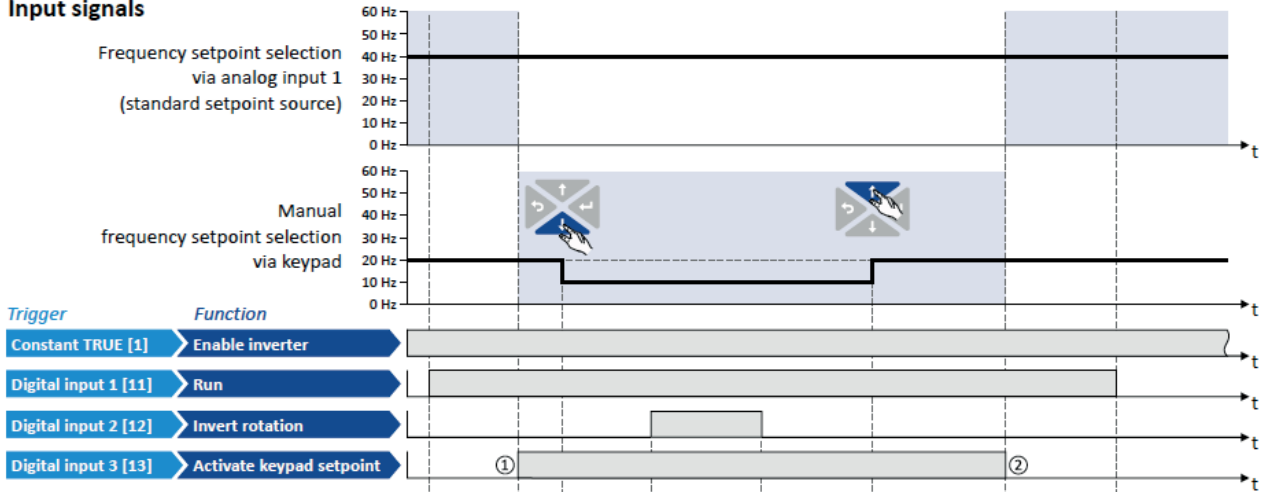

Output signals

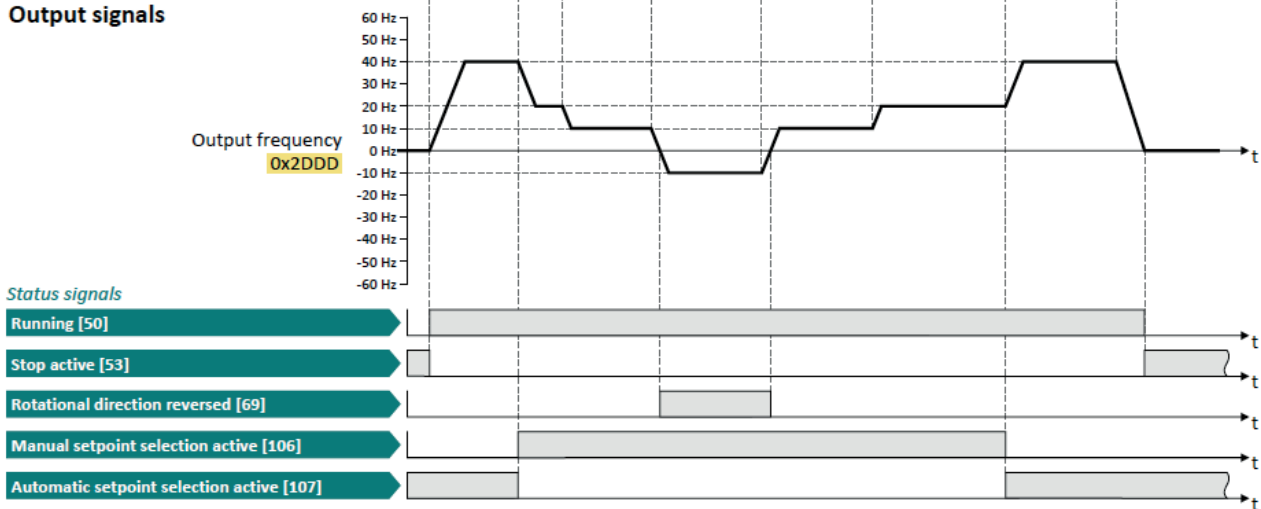

The status signals can be assigned to digital outputs.

- ① Change-over from analog input 1 (standard setpoint source) to keypad setpoint.
- ② Change-over from keypad setpoint back to analog input 1 (standard setpoint source).

Example 3: Change-over from keypad setpoint to preset 1 ... 7

The four functions "Activate preset (bit 0)" ... "Activate preset (bit 3)" enable change-over of the setpoint to a parameterisable setpoint (preset value).

Details

A preset is selected in a binary-coded fashion via the triggers assigned to the four functions "Activate preset (Bit 0)" ... "Activate preset (Bit 3)" in compliance with the following truth table:

Activate preset				Selection			
Bit 3 (P400:21)	Bit 2 (P400:20)	Bit 1 (P400:19)	Bit 0 (P400:18)	Preset	Frequency setpoint	PID setpoint	Torque setpoint
FALSE	FALSE	FALSE	FALSE	No preset selected			
FALSE	FALSE	FALSE	TRUE	Preset 1	P450:1	P451:1	P452:1
FALSE	FALSE	TRUE	FALSE	Preset 2	P450:2	P451:2	P452:2
FALSE	FALSE	TRUE	TRUE	Preset 3	P450:3	P451:3	P452:3
FALSE	TRUE	FALSE	FALSE	Preset 4	P450:4	P451:4	P452:4
FALSE	TRUE	FALSE	TRUE	Preset 5	P450:5	P451:5	P452:5
FALSE	TRUE	TRUE	FALSE	Preset 6	P450:6	P451:6	P452:6
FALSE	TRUE	TRUE	TRUE	Preset 7	P450:7	P451:7	P452:7
TRUE	FALSE	FALSE	FALSE	Preset 8	P450:8	P451:8	P452:8
TRUE	FALSE	FALSE	TRUE	Preset 9	P450:9		
...					
TRUE	TRUE	TRUE	TRUE	Preset 15	P450:15		

Example for operating mode

- The keypad is set as standard setpoint source.
- Switch S1 starts the motor in forward direction of rotation. Switch S1 in the initial position stops the motor again.
- The switches S2 ... S4 serve to switch over to the presets 1 ... 7 (see the following table).

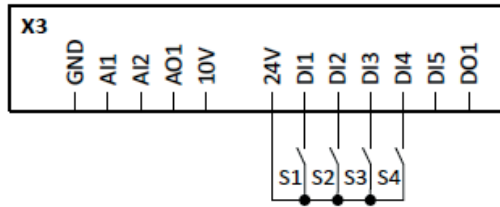

S1 = Run
S2, S3, S4 = Preset selection:

S2	S3	S4	
Off	Off	Off	Keypad setpoint
On	Off	Off	Preset 1
Off	On	Off	Preset 2
On	On	Off	Preset 3
Off	Off	On	Preset 4
On	Off	On	Preset 5
Off	On	On	Preset 6
On	On	On	Preset 7

Parameter	Name	Setting
P400:1	Enable VSD	Constant TRUE [1]
P400:2	Run	Digital input 1 [11]
P400:4	Reset fault	Not connected [0]
P400:13	Reverse rotational direction	Not connected [0]
P400:18	Activate preset (bit 0)	Digital input 2 [12]
P400:19	Activate preset (bit 1)	Digital input 3 [13]
P400:20	Activate preset (bit 2)	Digital input 4 [14]
P200:0	Control selection	Flexible I/O configuration [0]
P203:3	Stop method	Standard ramp [1]
P201:1	Frequency control: Default setpoint source	Keypad [1]
P450:1	Frequency setpoint presets: Preset 1	10 Hz
P450:2	Frequency setpoint presets: Preset 2	15 Hz
P450:3	Frequency setpoint presets: Preset 3	20 Hz
P450:4	Frequency setpoint presets: Preset 4	25 Hz
P450:5	Frequency setpoint presets: Preset 5	30 Hz
P450:6	Frequency setpoint presets: Preset 6	35 Hz
P450:7	Frequency setpoint presets: Preset 7	40 Hz

i If the frequency presets 8 ... 15 are required as well, the digital input 5 must be additionally assigned to the "Activate preset (bit 3)" function and the terminal DI5 must be interconnected accordingly.

Input signals

Frequency setpoint selection via keypad (standard setpoint source)

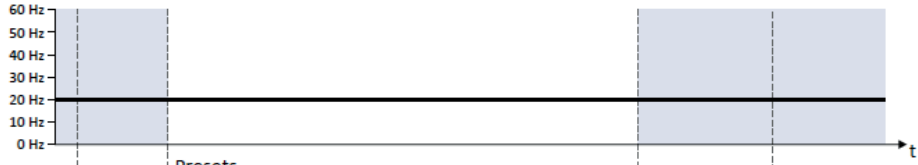

Presets						
0x2911:1	0x2911:2	0x2911:3	0x2911:4	0x2911:5	0x2911:6	0x2911:7
10 Hz	15 Hz	20 Hz	25 Hz	30 Hz	35 Hz	40 Hz

Trigger

Function

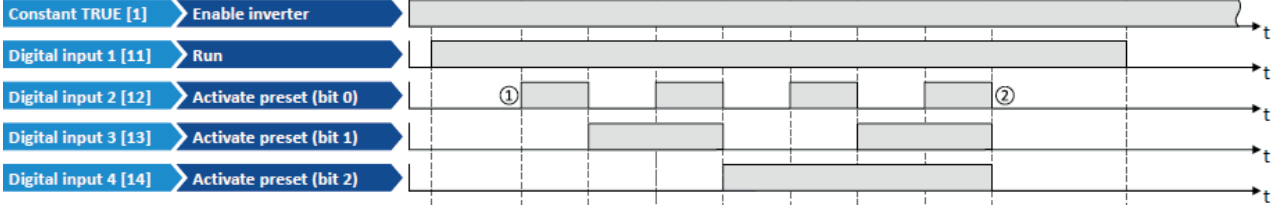

Output signals

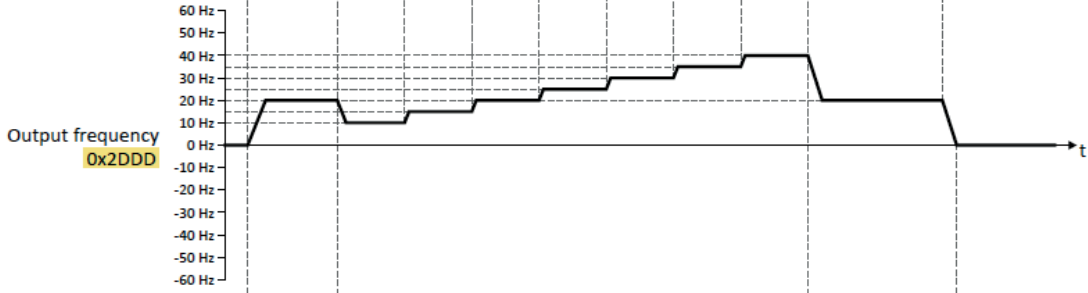

Status signals

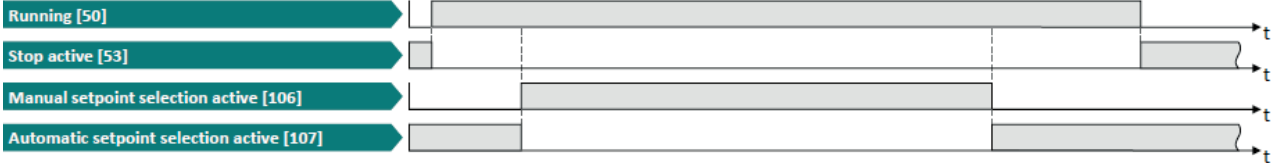

The status signals can be assigned to digital outputs.

- ① Change-over from keypad setpoint (standard setpoint source) to presets (first, preset 1 is selected).
- ② Change-over back to keypad setpoint since no preset is selected anymore (digital inputs 2 ... 4 = FALSE).

5.6.3 MOTOR POTENTIOMETER

With the motor potentiometer mode (MOP) the setpoint is controlled with two triggers (e.g. two digital inputs): "MOP setpoint up" (increase) and "MOP setpoint down" (decrease).

- The MOP is enabled by trigger P400:25 or can be set as default setpoint source.
- Motor potentiometer up TRUE: Setpoint will increase with acceleration time 2 P222:0.
- Motor potentiometer down TRUE: Setpoint will decrease with deceleration time 2 P223:0.
- MOP is increasing/decreasing the setpoint according acceleration/deceleration time 2. The motor is following the setpoint with acceleration/deceleration time 1 also in MOP-mode.
- If both triggers are TRUE or FALSE at the same time the setpoint will remain constant.
- The start value of the MOP is defined with P413:0.

P400:23	0x2631:23	Motor potentiometer (MOP) up			
0: Not connected (Reference see P400:1)		State TRUE will increase the speed setpoint in MOP-Mode.			
P400:24	0x2631:24	Motor potentiometer (MOP) down			
0: Not connected (Reference see P400:1)		State TRUE will decrease the speed setpoint in MOP-Mode.			
P400:25	0x2631:25	Activate MOP setpoint			
0: Not connected (Reference see P400:1)		Trigger to enable the MOP-Mode. After enabling the speed is controlled by digital inputs MOP up / MOP down.			
P413:0	0x4003:0	MOP Starting mode			
0: Last value 1: Init Value 2: Minimum Value		Defines the start setpoint value when MOP is enabled. 0: Last value MOP starts with the last MOP set value. 1: Init Value MOP starts with the value P414:1 for velocity mode, P414:2 for PID control, P414:3 for torque mode. 2: Minimum Value MOP starts with minimum frequency (P210:0) or minimum PID value (P605:1)			
P414:1	0x4004:1	MOP Starting value: frequency			
0.0 ... [0.0] ... 599.0 Hz		Frequency start value for MOP-Mode Note: Only active if P413:0 is set to 1			
P414:2	0x4004:2	MOP Starting value: PID			
-300.00 ... [0.00] ... 300.00 PUnit		Process controller start value for MOP-Mode Note: Only active if P413:0 is set to 1			
P414:3	0x4004:3	MOP Starting value: Torque			
0.0 ... [0.0] ... 1000,0%		Torque start value for MOP-mode (100% = motor rated torque P325:0) Note: Only active if P413:0 is set to 1			

5.6.4 USER DEFINED FAULTS

Two user defined fault can be configured. (Example: To stop motor in case of process fault) If a user defined fault occurs the VSD goes into fault state. After clearing the fault the resetting of the VSD is required.

P400:43	0x2631:43	User-defined fault 1			
0: Not connected (Reference see P400:1)		Configuration of user defined fault 1			
P400:44	0x2631:44	User-defined fault 2			
0: Not connected (Reference see P400:1)		Configuration of user defined fault 2			

5.6.5 SETPOINT SOURCE SEGMENT SETPOINTS

The four functions "Activate segment setpoint (bit 0) ..." "Activate segment setpoint´ (bit 3)" enable a setpoint change-over to a segment setpoint parameterised for the "sequencer" function during normal operation.

➡ See also chapter "Group 8 Sequencer"

A segment setpoint is selected in a binary-coded fashion via the triggers assigned to the four functions "Activate segment setpoint (bit 0) ..." "Activate segment setpoint´ (bit 3)" in compliance with the following truth table.

Activate segment setpoint				Selection			
Bit 3 (P400:29)	Bit 2 (P400:28)	Bit 1 (P400:27)	Bit 0 (P400:26)	Segment	Frequency setpoint	PID setpoint	Torque setpoint
FALSE	FALSE	FALSE	FALSE	No segment setpoint selected			
FALSE	FALSE	FALSE	TRUE	1	P801:1	P801:6	P801:7
FALSE	FALSE	TRUE	FALSE	2	P802:1	P802:6	P802:7
FALSE	FALSE	TRUE	TRUE	3	P803:1	P803:6	P803:7
FALSE	TRUE	FALSE	FALSE	4	P804:1	P804:6	P804:7
FALSE	TRUE	FALSE	TRUE	5	P805:1	P805:6	P805:7
FALSE	TRUE	TRUE	FALSE	6	P806:1	P806:6	P806:7
FALSE	TRUE	TRUE	TRUE	7	P807:1	P807:6	P807:7
TRUE	FALSE	FALSE	FALSE	8	P808:1	P808:6	P808:7
TRUE	FALSE	FALSE	TRUE	Invalid selection			
TRUE	TRUE	TRUE	TRUE				

P400:26	0x2631:26	Activate segment setpoint (bit 0)			
0: Not connected (Reference see P400:1)		Assignment of a trigger for the "Activate segment setpoint (bit 0)" function. Selection bit with the valency 2^0 for the bit-coded selection and activation of a parameterised segment setpoint. Trigger = FALSE: selection bit = "0". Trigger = TRUE: selection bit = "1". Notes: – During normal operation (no active sequence), this function serves to activate the setpoint of a segment (instead of an entire sequence in the sequencer operation). – This function is not intended for the use in the sequencer operation.			
P400:27	0x2631:27	Activate segment setpoint (bit 1)			
0: Not connected (Reference see P400:1)		Assignment of a trigger for the "Activate segment setpoint (bit 1)" function. Selection bit with the valency 2^1 for the bit-coded selection and activation of a parameterised segment setpoint. Trigger = FALSE: selection bit = "0". Trigger = TRUE: selection bit = "1". Notes: – During normal operation (no active sequence), this function serves to activate the setpoint of a segment (instead of an entire sequence in the sequencer operation). – This function is not intended for the use in the sequencer operation.			
P400:28	0x2631:28	Activate segment setpoint (bit 2)			
0: Not connected (Reference see P400:1)		Assignment of a trigger for the "Activate segment setpoint (bit 2)" function. Selection bit with the valency 2^2 for the bit coded selection and activation of a parameterised segment setpoint. Trigger = FALSE: selection bit = "0". Trigger = TRUE: selection bit = "1". Notes: – During normal operation (no active sequence), this function serves to activate the setpoint of a segment (instead of an entire sequence in the sequencer operation). – This function is not intended for the use in the sequencer operation.			
P400:29	0x2631:29	Activate segment setpoint (bit 3)			
0: Not connected (Reference see P400:1)		Assignment of a trigger for the "Activate segment setpoint (bit 3)" function. Selection bit with the valency 2^3 for the bit coded selection and activation of a parameterised segment setpoint. Trigger = FALSE: selection bit = "0". Trigger = TRUE: selection bit = "1". Notes: – During normal operation (no active sequence), this function serves to activate the setpoint of a segment (instead of an entire sequence in the sequencer operation). – This function is not intended for the use in the sequencer operation.			

5.6.6 HTL INPUT SETPOINT SOURCE

The digital inputs DI3 and DI4 can be configured as HTL input to evaluate the signal of a cost-effective HTL encoder or a reference frequency ("pulse train").

Many cost-effective control systems have a pulse-train output as an alternative to a real analog output.

- The HTL input can be defined as standard setpoint source.
- The "Activate setpoint via HTL input" P400:22 function enables a setpoint change-over to the HTL input.

Preconditions

- A setpoint change-over to the HTL input is only effected if no setpoint source with a higher priority has been selected.
- For using the digital inputs DI3 and DI4 as HTL input, the corresponding input function must be set in P410:2.

➔ See also chapter "5.5.8 Encoder settings"

Restrictions

- When the digital inputs DI3 and DI4 are configured as HTL input, these two digital inputs are no longer available for other control functions.
- The HTL input can be either used for detecting an HTL encoder signal or a pulse train. They cannot be used at the same time.
- The maximum input frequency of the digital inputs is 100 kHz. If this frequency is exceeded, an error is triggered.

Details

For detecting a pulse train, the following two configurations are supported:

- a) input function P410:2 = "Pulse train [2]"
(DI4 = input for pulse train, DI3 = normal digital input)

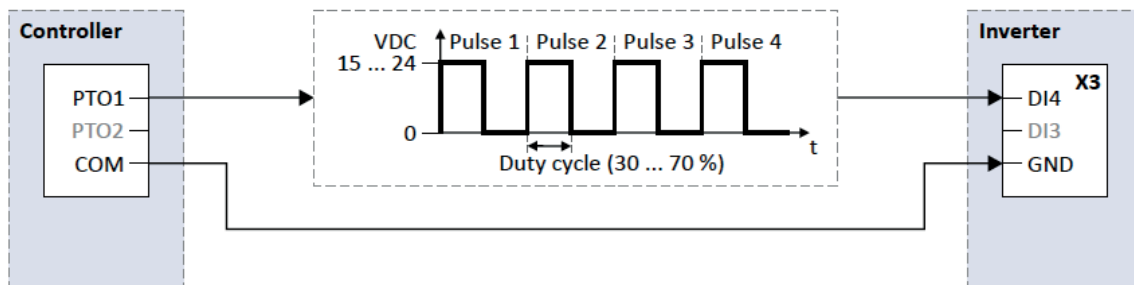

b) input function P410:2 = "Pulse train/direction [3]"
 (DI4 = input for pulse train, DI3 = input for specification of direction)

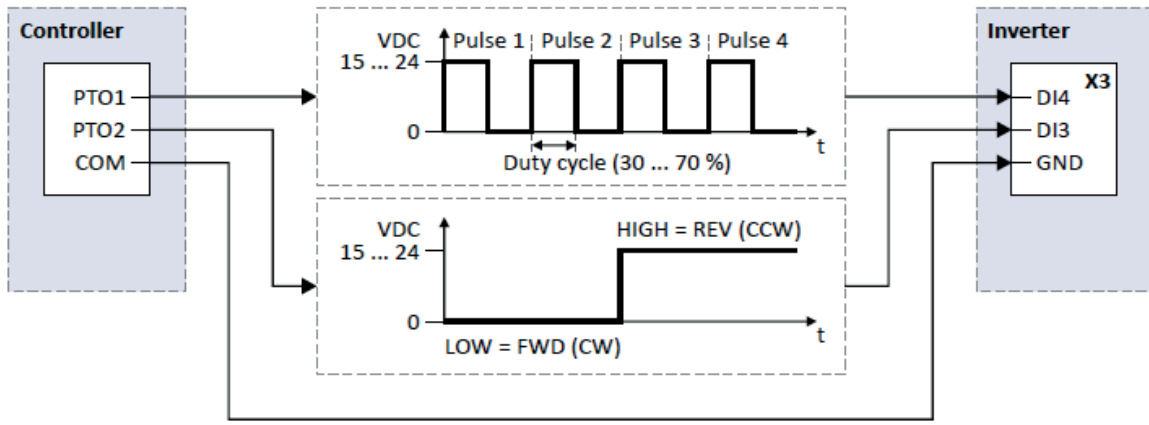

Scaling

The scaling of the frequency signal in relation to the setpoint range takes place in two steps can be configured as follows:

- Identify the minimum and maximum frequency of the frequency signal (pulse train).
- Set the minimum frequency value (Hz) P415:01

i When DI3 is used to control the pulse train P410:2= [3], this value must be configured to the corresponding NEGATIVE pulse frequency value.

- Set the maximum frequency value (Hz) P415:2

Area

Configure the range for the setpoint, which corresponds to the minimum and maximum frequency of the frequency signal (pulse train).

Frequency setpoint:

- Set minimum desired motor frequency (Hz) P415:3.
- Set maximum desired motor frequency (Hz) P415:4.

Process control:

- Set minimum desired PID setpoint (PID controller) P415:5.
- Set maximum desired PID setpoint (PID controller) P415:6.

Torque setpoint:

- Set minimum desired torque setpoint (% torque) P415:7.
- Set maximum desired torque setpoint (% torque) P415:8.

Filter

Filter time constant P415:9: in normal operation, the standard value is sufficient for executing this function.

Monitoring

It is also possible for the VSD to monitor the frequency input and generate a response when the frequency input falls below a predetermined frequency value and / or rises above a predetermined frequency value.

Configuration of VSD monitoring:

- Set minimum frequency threshold to the lowest valid input frequency (in Hz) P416:1.
- Set maximum frequency threshold to the highest valid input frequency (in Hz) P416:3.
- Set minimum deceleration threshold to the time period for which the input frequency needs to fall below the minimum threshold in order to cause an error status P416:2.
- Set maximum deceleration threshold to the time period for which the input frequency needs to exceed the maximum threshold in order to cause an error status P416:4.
- Set monitoring conditions P416:5.
- Set the error response to the desired action that occurs when the error "Frequency input monitoring error" is triggered P416:6.

The following settings are possible for the HTL input:

- Definition of the input range ①
- Filter time for low-pass filters ②
- Definition of the setting range ③
- Monitoring of the input signal ④

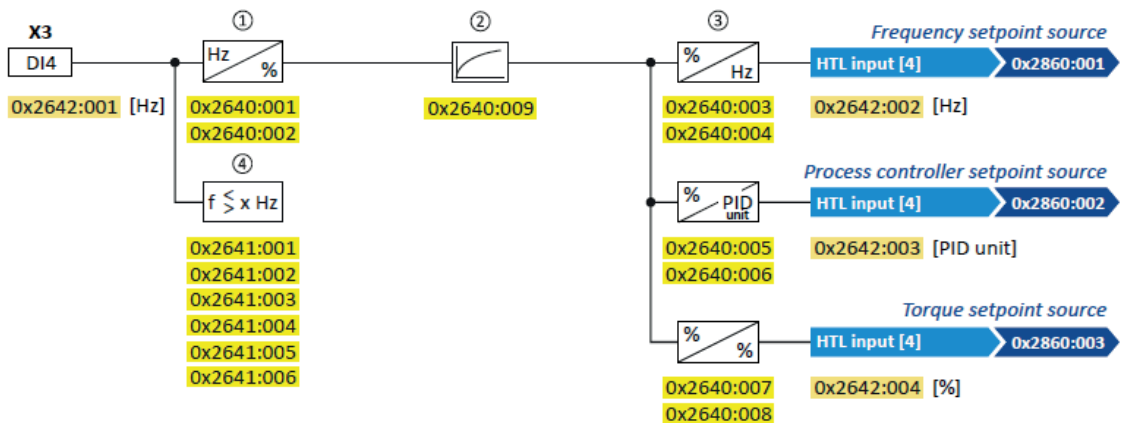

Intended use

The HTL input can be used for the following tasks:

- As a standard setpoint source

Intended use	Parameter	Setting
As a setpoint source for specifying a frequency setpoint.	P201:1	HTL input [4]
As setpoint source for defining the reference value for the process controller.	P201:2	HTL input [4]
As a setpoint source for specifying a torque setpoint.	P201:3	HTL input [4]

As an alternative to the setting as a standard setpoint source, the "Activate setpoint via HTL input" P400:22 function can be used to enable a setpoint change-over to the HTL input.

- As an actual value source or feedforward source for the following functions:

Intended use	Parameter	Setting
As an actual value source for the process controller.	P600:2	HTL input [6]
As a speed feedforward source for the process controller.	P600:4	HTL input [9]

For detecting an HTL encoder AB signal, the input function "HTL encoder (AB) [1]" must be set in P410:2 instead. More details for configuring the HTL encoder can be found in chapter "Encoder settings".

P400:22	0x2631:22	Activate setpoint via HTL input			
0: Not connected (Reference see P400:1)		Assignment of a trigger for the "Activate setpoint via HTL input" function. Trigger = TRUE: HTL input is used as setpoint source (if the trigger assigned has the highest setpoint priority). Trigger = FALSE: no action / deactivate function again.			
P415:1	0x2640:1	HTL input settings: Minimum frequency			
-100000.0 ... [0.0] ... 100000.0 Hz		Definition of the input range of the HTL input.			
P415:2	0x2640:2	HTL input settings: Maximum frequency			
-100000.0 ... [0.0] ... 100000.0 Hz		Definition of the input range of the HTL input.			
P415:3	0x2640:3	HTL input settings: Minimum motor frequency			
-1000.0 ... [0.0] ... 1000.0 Hz		Definition of the setting range for operating mode "MS: Velocity mode". – Direction of rotation according to sign. – The standard setpoint source for operating mode P301:0 = "MS: Velocity mode [-2]" is selected in P201:1.			
P415:4	0x2640:4	HTL input settings: Maximum motor frequency			
1000.0 ... [50.0] ... 1000.0 Hz		Definition of the setting range for operating mode "MS: Velocity mode". – Direction of rotation according to sign. – The standard setpoint source for operating mode P301:0 = "MS: Velocity mode [-2]" is selected in P201:1.			
P415:5	0x2640:5	HTL input settings: Minimum PID setpoint			
-300.00 ... [0.00] ... 300.00 PID unit		Definition of the setting range for PID control. – The standard setpoint source for the reference value of PID control is selected in P201:2.			
P415:6	0x2640:6	HTL input settings: Maximum PID setpoint			
-300.00 ... [100.00] ... 300.00 PID unit		Definition of the setting range for PID control. – The standard setpoint source for the reference value of PID control is selected in P201:2.			
P415:7	0x2640:7	HTL input settings: Minimum torque setpoint			
-400.0 ... [0.0] ... 400.0 %		Definition of the setting range for operating mode "MS: Torque mode". – 100 % ≙ Motor rated torque P325:0. – Direction of rotation according to sign. – The standard setpoint source for operating mode P301:0 = "MS: Torque mode [-1]" is selected in P201:3.			
P415:8	0x2640:8	HTL input settings: Minimum torque setpoint			
-400.0 ... [100.0] ... 400.		Definition of the setting range for operating mode "MS: Torque mode". – 100 % ≙ Motor rated torque P325:0. – Direction of rotation according to sign. – The standard setpoint source for operating mode P301:0 = "MS: Torque mode [-1]" is selected in P201:3.			
P415:9	0x2640:9	HTL input settings: Filter time constant			
0 ... [10] ... 10000 ms		PT1 time constant for low-pass filter.			
P416:1	0x2641:1	HTL input monitoring: Minimum frequency threshold			
-214748364.8 ... [0.0] ... 214748364.7 Hz		Settings for monitoring the HTL input.			
P416:2	0x2641:2	HTL input monitoring: Minimum delay threshold			
0.0 ... [5.0] ... 300.0 s		Settings for monitoring the HTL input.			
P416:3	0x2641:3	HTL input monitoring: Maximum frequency threshold			
-214748364.8 ... [0.0] ... 214748364.7 Hz		Settings for monitoring the HTL input.			
P416:4	0x2641:4	HTL input monitoring: Maximum delay threshold			
0.0 ... [5.0] ... 300.0 s		Settings for monitoring the HTL input.			
P416:5	0x2641:5	HTL input monitoring: Monitoring conditions			
1: Below minimum frequency 2: Above maximum frequency 3: Below min. or above max. frequency		1: Below minimum frequency Input frequency < minimum frequency threshold P416:1 longer than the deceleration P416:2. 2: Above maximum frequency Input frequency > maximum frequency threshold P416:3 longer than the deceleration P416:4. 3: Below min. or above max. frequency Input frequency < minimum frequency threshold P416:1 longer than the deceleration P416:2 OR input frequency > maximum frequency threshold P416:3 longer than the deceleration P416:4.			
P416:6	0x2641:6	HTL input monitoring: Error response			
1: Warning (Reference see P310:1)		Selection of the response to the triggering of the HTL input monitoring. • Associated error code: 28803 0x7083 - HTL input fault			

P410:2	0x2630:2	Settings for digital inputs: Input function
0: Digital input 1: HTL encoder (AB) 2: Pulse train 3: Pulse train/direction		Input function of the digital terminals DI3 and DI4. 0: Digital input DI3 = digital input DI4 = digital input 1: HTL encoder (AB) DI3 = HTL input for encoder track B DI4 = HTL input for encoder track A 2: Pulse train – available from version 4.1 DI3 = digital input DI4 = HTL input for pulse train 3: Pulse train/direction – available from version 4.1 DI3 = HTL input for direction specification; HIGH level = counter-clockwise (CCW) DI4 = HTL input for pulse train

Diagnostic parameters:

- The input frequency is displayed in P115:1 (read only x.x Hz).
- The scaled frequency value is displayed in P115:2 (read only x.x Hz).
- The scaled process controller value is displayed in P115:3 (read only x.xx PID unit).
- The scaled torque value is displayed in P115:4 (read only x.x%).

Configuration example.

Example 1: Input range 10 ... 85 kHz \equiv setting range 0 ... 50 Hz

In this configuration, a frequency setpoint between 0 and 50 Hz can be set with an HTL input frequency between 10 and 85 kHz.

Parameter	Name	Setting
P415:1	HTL input settings: Minimum frequency	10000.0 Hz
P415:2	HTL input settings: Maximum frequency	85000.0 Hz
P415:3	HTL input settings: Minimum motor frequency	0.0 Hz
P415:4	HTL input settings: Maximum motor frequency	50.0 Hz
P415:9	HTL input settings: Filter time constant	10 ms

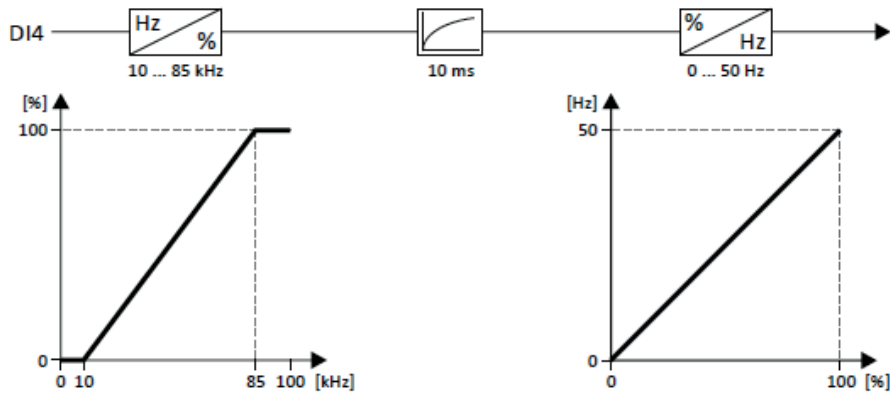

Example 2: Pulse train as frequency setpoint source

This example shows a configuration to control the frequency setpoint of the VSD pulse train:

- Switch S1 starts the motor. Switch S1 in the initial position stops the motor again.
- Scaling of the pulse train signal: Input range 10 ... 85 kHz \equiv setting range -50 ... 50 Hz.
- HTL input monitoring is configured in such a way that a warning is output if the pulse train signal falls below the minimum input frequency of 10 kHz for longer than 2 s.

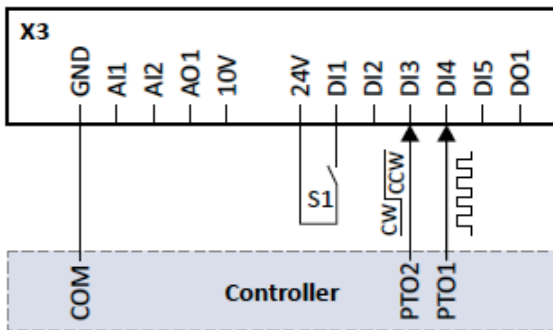

- Switch S1: Run
- PTO1: Pulse train output of the Controller
- PTO2: Specification of direction of rotation of the Controller

Parameter	Name	Setting
P400:1	Enable VSD	Constant TRUE [1]
P400:2	Run	Digital input 1 [11]
P410:2	Settings for digital inputs: Input function	Pulse train/direction [3]
P210:1	Frequency control: Default setpoint source	HTL input [4]
HTL input settings		
P415:1	HTL input settings: Minimum frequency	10000.0 Hz
P415:2	HTL input settings: Maximum frequency	85000.0 Hz
P415:3	HTL input settings: Minimum motor frequency	0.0 Hz
P415:4	HTL input settings: Maximum motor frequency	50.0 Hz
P415:9	HTL input settings: Filter time constant	10 ms
HTL input monitoring		
P416:1	Minimum frequency threshold	10000.0 Hz
P416:2	Minimum delay threshold	2.0 s
P416:5	Monitoring conditions	Below minimum frequency [1]
P416:6	Error response	Warning [1]

Input signals

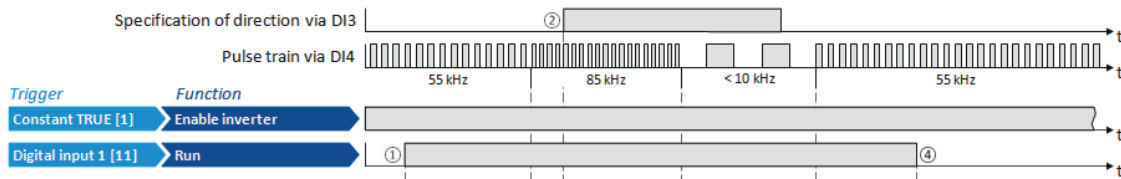

Output signals

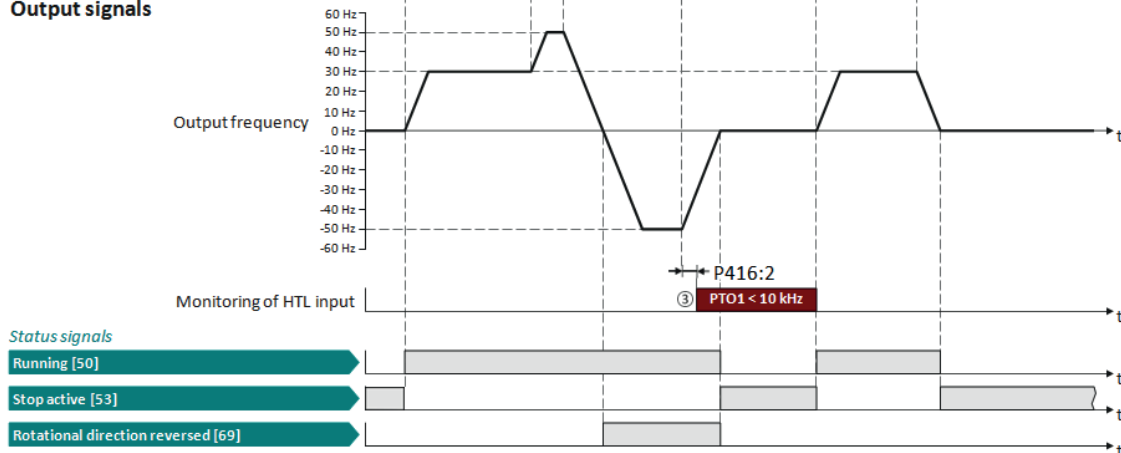

- ① If the VSD is enabled and no error is active, the motor can be started with the "Run" function. The motor follows the pulse train according to the set input and setting range.
- ② The "counter-clockwise (CCW)" direction of rotation is requested externally (Controller; PTO2) via digital input DI3.
- ③ If the pulse train signal falls below the input frequency of 10 kHz, for longer than 2 s, a warning is output.
- ④ If "Run" is set to FALSE, the motor is stopped with the stop method set in P203:3. In the example: Stop with standard ramp.

5.6.7 ACTIVATING DC BRAKING MANUALLY

By means of the "Activate DC braking" function, DC braking can be activated manually

P400:5	0x2631:5	Activate DC braking			
0: Not connected (Reference see P400:1)		Trigger = TRUE: Activate DC braking. Trigger = FALSE: Deactivate DC braking. CAUTION! DC braking remains active as long as the trigger is set to TRUE.			
P704:1	0x2B84:1	DC braking: Current			
0.0 ... [0.0] ... 200.0 %		Braking current for DC braking. 100 % = rated motor current (P323:0)			

For more information see chapter "DC BRAKE SETUP"

5.6.8 RELEASING HOLDING BRAKE MANUALLY

The "Release holding brake" function serves to release the holding brake immediately. Brake application time and brake opening time as well as the conditions for the automatic operation are not effective.

Preconditions

- Observe setting and application notes in the chapter "5.9.8 Holding brake control"
- The brake mode "Automatic [0]" or "Manual [1]" must be set in P712:1.
- The "Release holding brake [115]" trigger has to be assigned to a digital output or, in the simplest case, to the relay which then switches the brake supply.

Details

P400:49	0x2631:49	Release holding brake			
0: Not connected (Reference see P400:1)		Assignment of a trigger for the "Release holding brake" function. Trigger = TRUE: Release holding brake (immediately). Trigger = FALSE: no action. Notes: - Function is only executed if the brake mode P712:1 is set to "Automatic [0]" or "Manual [1]". CAUTION! - The manually triggered "Release holding brake" command has a direct impact on the "Release holding brake [115]" trigger. Thus, the holding brake can be manually released if the power section is switched off! - The responsibility for a manual release of the holding brake has the external trigger source for the "Release holding brake" command!			

Detailed information about the function and configuration of the holding brake control can be found in the chapter "5.9.8 Holding brake control".

5.6.9 FUNCTIONS FOR PARAMETER CHANGE-OVER

The VSD supports several parameter sets. The parameter set can be selected by means of the "Select parameter set (bit 0)" and "Select parameter set (bit 1)" functions.

DANGER!

Changed parameter settings can become effective immediately depending on the activating method set in P755:0.

The possible consequence is an unexpected response of the motor shaft while the VSD is enabled.

- ▶ If possible, only carry out parameter changes while the VSD is disabled.
- ▶ Certain device commands or settings which might cause a critical state of the drive behavior can generally only be carried out when the VSD is inhibited.

Details

The "parameter change-over" function provides a change-over between four sets with different parameter values for up to 32 freely selectable parameters. For details on the compilation of the parameters and setting of the value sets, see the chapter "5.9.1.5 Parameter change-over".

A value set is selected in a binary-coded fashion via the triggers assigned to the two "Select parameter set (bit 0)" and "Select parameter set (bit 1)" functions in compliance with the following truth table:

Select parameter set (bit 1) P400:42	Select parameter set (bit 0) P400:41	Selection
FALSE	FALSE	Value set 1
FALSE	TRUE	Value set 2
TRUE	FALSE	Value set 3
TRUE	TRUE	Value set 4

Change-over is effected depending on the activation method selected in P755:0 when a state change of the selection inputs takes place or via the trigger assigned to the "Load parameter set" function.

P400:40	0x2631:40	Load parameter set			
0: Not connected (Reference see P400:1)		Assignment of a trigger for the "Load parameter set" function. Trigger = FALSE-TRUE edge: parameter change-over to the value set selected via "Select parameter set (bit 0)" and "Select parameter set (bit 1)". Trigger = FALSE: no action. Notes: – The activation method for the "Parameter change-over" function can be selected in P755:0.			
P400:41	0x2631:41	Select parameter set (bit 0)			
0: Not connected (Reference see P400:1)		Assignment of a trigger for the "Select parameter set (bit 0)" function. Selection bit with the valency 2 ⁰ for "Parameter change-over" function. Trigger = FALSE: selection bit = "0". Trigger = TRUE: selection bit = "1".			
P400:42	0x2631:42	Select parameter set (bit 1)			
0: Not connected (Reference see P400:1)		Assignment of a trigger for the "Select parameter set (bit 1)" function. Selection bit with the valency 2 ¹ for "Parameter change-over" function. Trigger = FALSE: selection bit = "0". Trigger = TRUE: selection bit = "1".			
P755:0	0x4046	Activation of parameter set			
0: Via command (disable required) 1: Via command (immediately) 2: If the selection is changed (disable required) 3: If the selection is changed (immediately)		Selection of the activation method for the parameter change-over. – If the selection is changed from "Via command... [0]/[1]" to "If the selection is changed...[2]/[3]" after switch-on, the parameter set selected via the functions "Select parameter set (bit 0)" and "Select parameter set (bit 1)" is activated immediately. In case of selection [2], however, this only takes place if the VSD is disabled, the motor is stopped or an error is active. 0: Via command (disable required) The parameter set selected via the functions "Select parameter set (bit 0)" and "Select parameter set (bit 1)" is activated if the trigger assigned to the "Load parameter set" function in P400:40 provides a FALSE-TRUE edge AND the VSD is inhibited, the motor is stopped or an error is active. 1: Via command (immediately) The parameter set selected via the functions "Select parameter set (bit 0)" and "Select parameter set (bit 1)" is immediately activated if the trigger assigned to the "Load parameter set" function in P400:40 provides a FALSE-TRUE edge. 2: If the selection is changed (disable required) The parameter set selected via the functions "Select parameter set (bit 0)" and "Select parameter set (bit 1)" is activated if the state of these selection bits changes AND the VSD is inhibited, the motor is stopped or an error is active. 3: If the selection is changed (immediately) The parameter set selected via the functions "Select parameter set (bit 0)" and "Select parameter set (bit 1)" is activated immediately if the state of these selection bits is changed.			

5.6.10 UPS OPERATION

This function enables the operation of a three-phase 400V variable speed drive with an uninterruptible single phase 230V power supply (UPS) to be able to operate the motor with reduced load for a certain period in the event of a power failure.

NOTES

- This function is available from firmware version 5.1
- UPS operation is not suitable for a continuous operation.
Possible consequence: Device overload
 - ▶ Prevent a too frequent use of this function.

Restrictions

- UPS operation is only available for VLB3 up to 11 kW.
- For UPS operation, one reduced output current and one reduced overload are available only:
 - Output current: 60 % of the 400V rated current
 - Overload: 80 %/5 min, 120 %/3 s of the 400V rated current
- In order to change over to UPS operation, a minimum delay of 10 s is required.

Details

The following figure shows the principal connection of the UPS to the VLB3. For further technical details, please contact the VSD manufacturer.

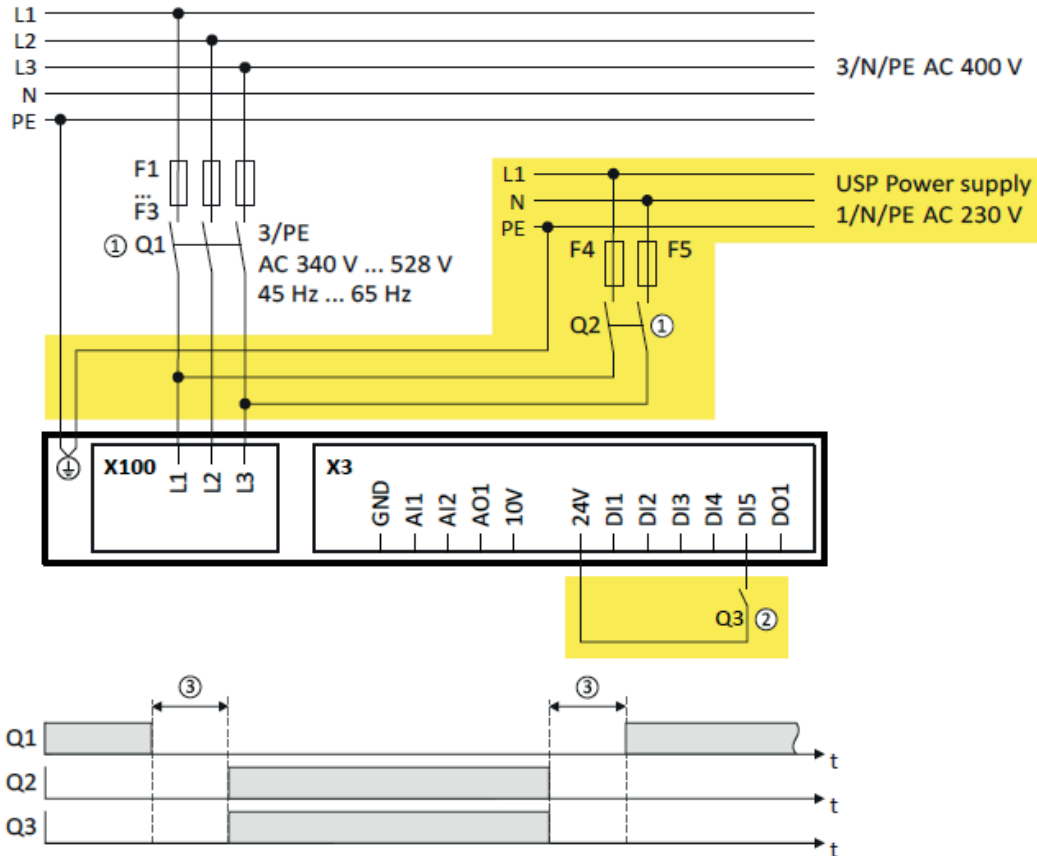

- ① A mutual locking is required for the contactors Q1 and Q2.
- ② In this example, the digital input DI5 is used to activate the UPS operation. For this purpose, the function "Activate UPS operation" P400:55 must be assigned to trigger "Digital input 5 [15]".
- ③ In order to change over to UPS operation, a minimum delay of 10 s is required.

The UPS operation can be alternatively activated via network. In this case, a bit of the mappable data word NetWordIN1 P590:1 must be assigned to the "Activate UPS operation [55]" function.

If the UPS operation is active,

- The device overload monitoring (i^*) is adapted accordingly.
- The DC limit values are reduced.
- The phase failure detection is switched off.
- The warning "UPS operation active" (error code 12672 | 0x3180) is output.
- Trigger "UPS operation active [118]" is set to TRUE. The trigger can be assigned to a digital output.
- Bit 15 ("UPS operation active") in the drive status word 2 0x2833 is set to "1".

Notes:

- An additional limitation of speed, current, etc. can be realised via the application with the "Parameter change-over" function.

Parameter				
P400:55	0x2631:055	Activate UPS operation		
0: Not connected (Reference: see P400:1)		Assignment of a trigger to the "Activate UPS operation" function. Trigger = TRUE: Activate UPS operation. Trigger = FALSE: no action / deactivate function again.		

Parameter		
Parameter	Designation	Setting for this example
P400:1	VSD enable	Constant TRUE [1]
P400:2	Run	Digital input 1 [11]
P400:55	Activate UPS operation	Digital input 5 [15]

Input signals

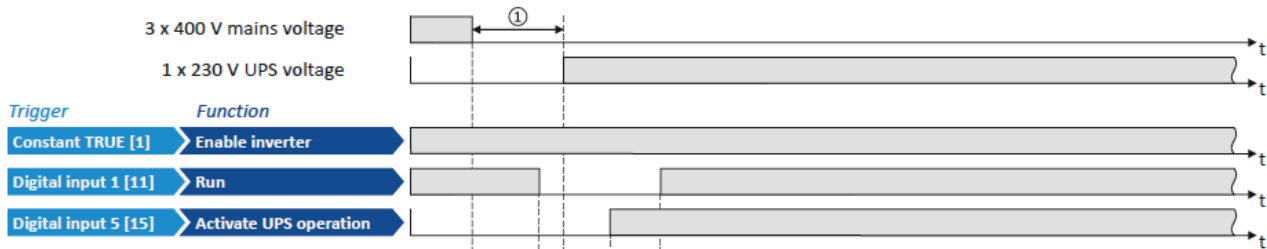

Output signals

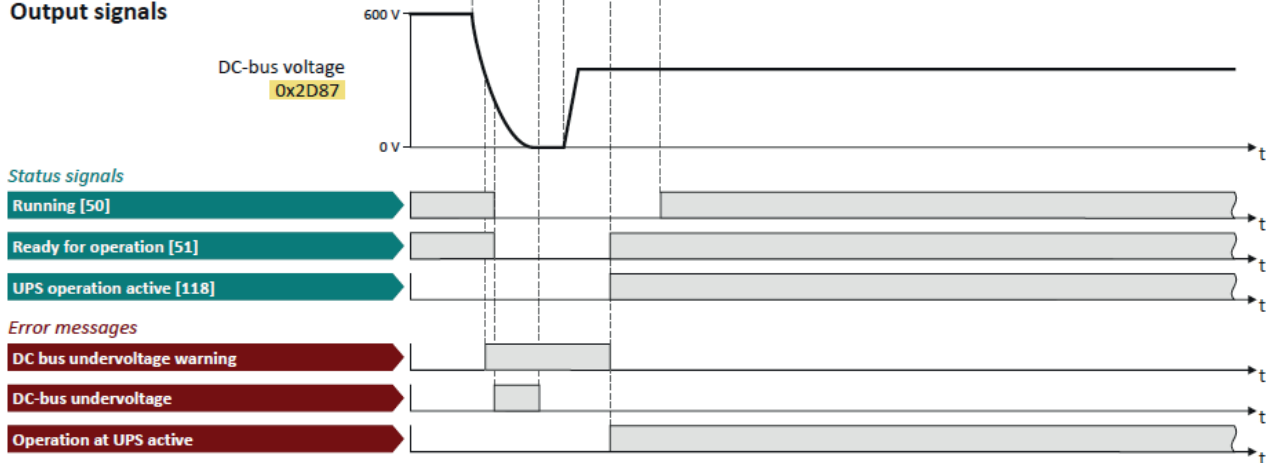

The status signals can be assigned to digital outputs.

① In order to change over to UPS operation, a minimum delay is required.

5.6.11 DIGITAL INPUT CONFIGURATION

The digital inputs are used for control operations. The following configurations are available for the digital inputs signals.

Assertion level "HIGH active" or "LOW active"

The digital inputs can be configured in P410:1 HIGH active (default setting) or LOW active:

HIGH active (default setting)	LOW active
<ul style="list-style-type: none"> Internally, the digital input terminals are set to LOW level via pulldown resistors. The current flows from the current supply (e.g. X3/24V) through the contact to the digital input terminal (and internally via the pull-down resistor to GND). If the contact is closed, the digital input is set to HIGH level and is thus HIGH active. 	<ul style="list-style-type: none"> Internally, the digital input terminals are set to HIGH level via pull-up resistors. The current flows from the digital input terminal through the contact to GND. If the contact is closed, the digital input is set to LOW level and is thus LOW active.
<p>Connection plan (example):</p>	<p>Connection plan (example):</p>

Debounce time

For minimising interference pulses, a debounce time of 1 ms is set for all digital inputs.
Via VLBXSW01 software (or network), the debounce time for can be increased individually for each digital input to maximally 50 ms.

Inversion

Each digital input can be configured in such a way that the status pending at the terminal is internally inverted logically. This way, a closed contact, for instance, serves to deactivate an assigned function instead of activating it. Thus, the control of the VSD can be flexibly adapted to the requirements of the actual application.

Functions

In general a digital input is assigned to a specific function (e.g. Run, Quick stop, ...). It is possible to have more than one function on the same digital input. See chapter "5.6.1 Function list" for the configurable functions.

P410:1	0x2630:1	Digital inputs assertion level			
0: LOW active 1: HIGH active		Input signal assertion for PNP/NPN selection 0: Low For NPN input signals (common: GND) 1: High For PNP input signals (common: 24V)			
P410:2	0x2630:2	Settings for digital inputs: Input function			
0: Digital input 1: HTL encoder (AB) 2: Pulse train 3: Pulse train/direction		Input function of the digital terminals DI3 and DI4. 0: Digital input DI3 = digital input DI4 = digital input 1: HTL encoder (AB) DI3 = HTL input for encoder track B DI4 = HTL input for encoder track A 2: Pulse train – available from version 4.1 DI3 = digital input DI4 = HTL input for pulse train 3: Pulse train/direction – available from version 4.1 DI3 = HTL input for direction specification; HIGH level = counter-clockwise (CCW) DI4 = HTL input for pulse train			
P411:1	0x2632:1	Digital input 1			
0: Not inverted 1: Inverted		Inversion of Digital Input			
P411:2	0x2632:2	Digital input 2			
0: Not inverted 1: Inverted		Inversion of Digital Input			
P411:3	0x2632:3	Digital input 3			
0: Not inverted 1: Inverted		Inversion of Digital Input			
P411:4	0x2632:4	Digital input 4			
0: Not inverted 1: Inverted		Inversion of Digital Input			
P411:5	0x2632:5	Digital input 5			
0: Not inverted 1: Inverted		Inversion of Digital Input			

5.6.12 FREQUENCY THRESHOLD SETUP

A frequency threshold can be used to trigger a function, a digital output or the relay. The trigger is referenced to actual VSD output frequency. This trigger is TRUE when the actual output frequency is above a programmable frequency threshold.

P412:0	0x4005:0	Frequency threshold			
0.0 ... [0.0] ... 599.0 Hz		Frequency threshold			

5.6.13 DIGITAL OUTPUTS CONFIGURATION

The digital outputs (Relay, DO) can be configured:

- Functionality can be selected
- Inversion of Output (Only Relay and DO)

P420:1	0x2634:1	Relay function			
0: Not connected 1: Constant TRUE 11: Digital input 1 12: Digital input 2 13: Digital input 3 14: Digital input 4 15: Digital input 5		0: Not Connected / always false 1: TRUE always 11-17: TRUE when corresponding digital input is asserted 30-49: TRUE when selected bit of the NETWordIn is high. 50: TRUE when the VSD is running. FALSE when VSD is disabled, DC-Brake active, quick stopped and speed <0.2Hz, faulted or stopped. 51: TRUE when VSD not in Failure, Safety OK and DC link charged (SW 02.01) 52: TRUE when the VSD is enabled. 53: TRUE when VSD is enabled, output=0V, not running and not faulted			

30: Netword IN1 - bit 12		54: TRUE when quick stop is selected and active.			
31: Netword IN1 - bit 13		55: TRUE if the integrated safety system has inhibited the VSD.			
32: Netword IN1 - bit 14		56: TRUE when the VSD has a fault condition.			
33: Netword IN1 - bit 15		57: TRUE when the VSD has a fault condition that is locked and cannot be reset.			
34: NETWordIN2 - bit 0		58: TRUE when a warning is present.			
35: NETWordIN2 - bit 1		59: TRUE when a trouble condition is present.			
36: NETWordIN2 - bit 2		60: TRUE when the heat sink temperature exceeds the warning level			
37: NETWordIN2 - bit 3		65: TRUE when a PTC fault is detected.			
38: NETWordIN2 - bit 4		66: TRUE when a flying start or a restart is active			
39: NETWordIN2 - bit 5		67: TRUE when the DC brake is on.			
40: NETWordIN2 - bit 6		69: TRUE when output frequency is negative			
41: NETWordIN2 - bit 7		70: TRUE when the output frequency is > the frequency threshold (P412:0)			
42: NETWordIN2 - bit 8		71: TRUE when the output frequency is zero +/- 0.01Hz			
43: NETWordIN2 - bit 9		72: TRUE when the VSD reaches the commanded setpoint and setpoint <> 0 Hz			
44: NETWordIN2 - bit 10		73: TRUE when the PID feedback is equal to the programmed setpoint +/- 2%			
45: NETWordIN2 - bit 11		74: TRUE when in Sleep mode			
46: NETWordIN2 - bit 12		75: TRUE when a minimum alarm is triggered (reference to P608:1)			
47: NETWordIN2 - bit 13		76: TRUE when a maximum alarm is triggered (reference to P608:2)			
48: NETWordIN2 - bit 14		77: TRUE when no minimum/maximum alarm is active. (reference to P608:1 & P608:2)			
49: NETWordIN2 - bit 15		78: TRUE when the actual motor current has exceeded the level in P324:0.			
50: Running		79: TRUE when the actual torque has exceeded the level in P326:0, 0x60E0:0 or 0x60E1:0.			
51: Ready for operation		81: TRUE when loss of the analog input 1 has been detected. P430:8-10			
52: VSD enable		82: TRUE when loss of the analog input 2 has been detected. P431:8-10			
53: Stop active		83: TRUE when no load is detected			
54: Quick stop active		100: TRUE when the control is executed via the sequencer.			
55: VSD disabled (safety)		101: TRUE if the sequence is running and is currently not suspended.			
56: Fault active		102: TRUE if the sequence is currently suspended.			
57: Fault interlocking		103: TRUE if the sequence is completed.			
58: Device warning		104: TRUE when local (LOC) mode is active (local keypad control)			
59: Trouble active		105: TRUE when remote (REM) mode is active (all control sources EXCEPT keypad control)			
60: Heatsink temp. warn. active		106: TRUE when manual (MAN) mode is active (Keypad setpoint control)			
65: PTC fault		107: TRUE when automatic (AUTO) mode is active (All setpoint sources other than Keypad)			
66: Flying restart		108: TRUE when parameter set #1 is loaded and active.			
67: DC brake active		109: TRUE when parameter set #2 is loaded and active.			
69: Inverse rotation		110: TRUE when parameter set #3 is loaded and active.			
70: Frequency thld exceeded		111: TRUE when parameter set #4 is loaded and active.			
71: Actual speed = 0		112: TRUE after any parameter set 1...4 change-over has completed without error.			
72: Setpoint speed reached		113: TRUE when any parameter set load fails.			
73: PID feedback = setpoint		115: TRUE when brake release signal is TRUE (either by auto trigger or manual trigger).			
74: PID idle state active		117: TRUE if a motor phase failure has been detected.			
75: PID min alarm active		118: TRUE if UPS operation is active.			
76: PID max alarm active		155: TRUE if the integrated safety system has triggered the "Safe Torque Off" (STO) function and if the safe inputs SIA and SIB = LOW (simultaneously).			
77: PID min-max alarm active					
78: At current limit					
79: At torque limit					
81: Error analog input 1					
82: Error analog input 2					
83: Loss of load					
100: Sequencer controlled					
101: Sequence active					
102: Sequence suspended					
103: Sequence done					
104: Local control active					
105: Remote control active					
106: Manual setpoint active					
107: Automatic setpoint active					
108: Parameter set 1 active					
109: Parameter set 2 active					
110: Parameter set 3 active					
111: Parameter set 4 active					
112: Parmeter set load OK					
113: Parameter set load fail					
115: Holding brake release					
117: Motor phase failure					
118: UPS operation active					
155: STO active					
P420:2	0x2634:2	Digital output 1 function			
115:Holding brake release (Reference see P420:1)		Function of Digital Output 1 (Reference list see P420:1)			
P421:1	0x2635:1	Inversion of relay output			
0: Not inverted 1: Inverted		Inversion of Relay Output			
P421:2	0x2635:2	Inversion of digital output 1			
0: Not inverted 1: Inverted		Inversion of Digital Output 1			

5.6.14 ANALOG INPUT SETTINGS

The VSD is equipped with two analog inputs. These can be configured as reference or feedback signal.

The following settings are available:

- Input configuration
- Input filter time / Input Dead time
- Input monitoring function
- Input scaling

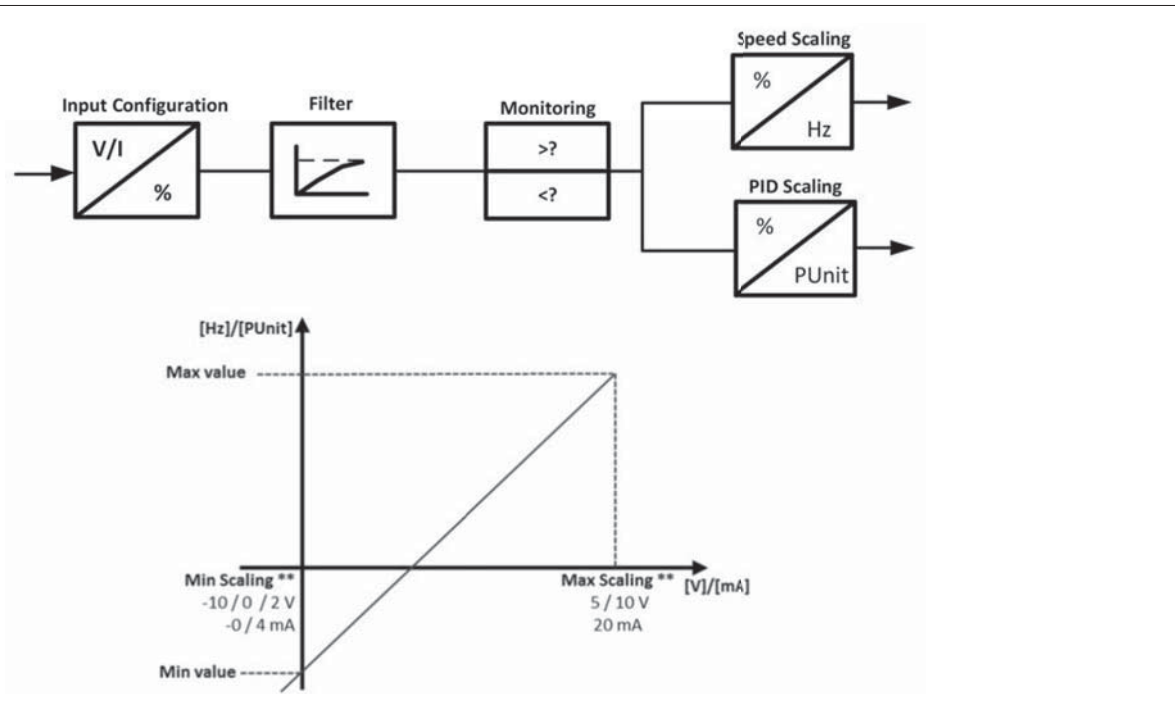

** Availability of scaling depending on type of VSD.

P430:1	0x2636:1	AI 1 configuration			
0: 0...10VDC 1: 0...5VDC 2: 2...10VDC 3: -10...+10VDC 4: 4...20mA 5: 0...20mA		Configuration of input range of Analog input 1.			
P430:2	0x2636:2	Analog input 1: Min frequency value [Hz]			
-1000.0 ... [0.0] ... 1000.0 Hz		Frequency scaling of the analog input Represents the minimum of the analog input value			
P430:3	0x2636:3	Analog input 1: Max frequency value [Hz]			
-1000.0 ... [50.0] ... 1000.0 Hz		Frequency scaling of the analog input Represents the maximum of the analog input value			
P430:4	0x2636:4	Analog input 1: Min PID value [Punit/%]			
-300.00 ... [0.00] ... 300.00 PUnit/%		PID scaling of the analog input Represents the minimum of the analog input value			
P430:5	0x2636:5	Analog input 1: Max PID value [Punit/%]			
-300.00 ... [100.00] ... 300.00 PUnit/%		PID scaling of the analog input Represents the maximum of the analog input value			
P430:6	0x2636:6	Analog input 1: Filter time			
0 ... [10] ... 10000 ms		Analog input filter time constant			
P430:7	0x2636:7	Analog input 1: Deadband			
0.0 ... [0.0] ... 100.0 %		Configuration of the deadband such that any input value below this percentage will be treated as 0Hz. (In % of Max Input Value) Example: Deadband 10% of 50Hz: -10V ... 10V Deadband -5Hz ... 5 Hz 0 ... 10V Deadband 0Hz ... 5 Hz			
P430:8	0x2636:8	Analog input 1: Monitoring threshold			
-100.0 ... [0.0] ... 100.0 %		Monitoring threshold of the analog input (example: 100% = 10V if AI1 is configured as 0-10V voltage input).			
P430:9	0x2636:9	Analog input 1: Monitoring condition			
0: Below trigger threshold 1: Above trigger threshold		Monitoring condition of the analog input 1. If the selected condition is met, the "Error of analog input 1 active [81]" trigger is set to true.			
P430:10	0x2636:10	Analog input 1: Error response			
3: Fault (Reference see P310:1)		The selected response takes place if the monitoring condition selected in P430:9 is met for at least 500ms.			
P430:11	0x2636:11	Analog input 1: Min torque value			
-400.0 ... [0.0] ... 400.0 %		Definition of the setting range for operating mode "MS: Torque mode". 100% = max permissible torque (P326:0). Direction of rotation according to sign. The standard setpoint source for operating mode P301:0 = "MS: Torque mode [1]" is selected in P201:3			
P430:12	0x2636:12	Analog input 1: Max torque value			
-400.0 ... [100.0] ... 400.0 %		See P430:11			

P431:1	0x2637:1	AI2 configuration			
0: 0...10VDC 1: 0...5VDC 2: 2...10VDC 3: -10...+10VDC 4: 4...20mA 5: 0...20mA (*)		Configuration of input range of Analog input 2.			
P431:2	0x2637:2	Analog input 2: Min value [Hz]			
-1000.0 ... [0.0] ... 1000.0 Hz		Frequency scaling of the analog input Represents the minimum of the analog input value			
P431:3	0x2637:3	Analog input 2: Max value [Hz]			
-1000.0 ... [50.0] ... 1000.0 Hz		Frequency scaling of the analog input Represents the maximum of the analog input value			
P431:4	0x2637:4	Analog input 2: Min value [Punit/%]			
-300.00 ... [0.00] ... 300.00 PUnit/%		PID/Torque scaling of the analog input Represents the minimum of the analog input value			
P431:5	0x2637:5	Analog input 2: Max value [Punit/%]			
-300.00 ... [100.00] ... 300.00 PUnit/%		PID/Torque scaling of the analog input Represents the maximum of the analog input value			
P431:6	0x2637:6	Analog input 2: Filter time			
0 ... [10] ... 10000 ms		Analog input filter time constant			
P431:7	0x2637:7	Analog input 2: Deadband			
0.0 ... [0.0] ... 100.0 %		Configuration of the deadband such that any input value below this percentage will be treated as 0Hz. (In % of Max Input Value) Example: Deadband 10% of 50Hz: -10V ... 10V Deadband -5Hz ... 5 Hz 0 ... 10V Deadband 0Hz ... 5 Hz			
P431:8	0x2637:8	Analog input 2: Monitoring level threshold			
-100.0 ... [0.0] ... 100.0 %		Monitoring threshold of the analog input			
P431:9	0x2637:9	Analog input 2: Monitoring condition			
0: Below trigger threshold 1: Above trigger threshold		Monitoring condition of the analog input 2. If the selected condition is met, the "Error of analog input 2 active [82]" trigger is set to TRUE.			
P431:10	0x2637:10	Analog input 2: Error response			
3: Fault (Reference see P310:1)		The selected response takes place if the monitoring condition selected in P431:9 is met for at least 500ms.			
P431:11	0x2637:11	Analog input 2: Min torque value			
-400.0 ... [0.0] ... 400.0 %		Definition of the setting range for operating mode "MS: Torque mode". 100% = max permissible torque (P326:0). Direction of rotation according to sign. The standard setpoint source for operating mode P301:0 = "MS: Torque mode [1]" is selected in P201:3			
P431:12	0x2637:12	Analog input 2: Max torque value			
-400.0 ... [100.0] ... 400.0 %		See P431:11			

5.6.15 ANALOG OUTPUT SETTINGS

The analog output can be used to send a feedback signal to the control system (i. e. Motor current, Actual Frequency, ...). Different functions and output configurations are available.

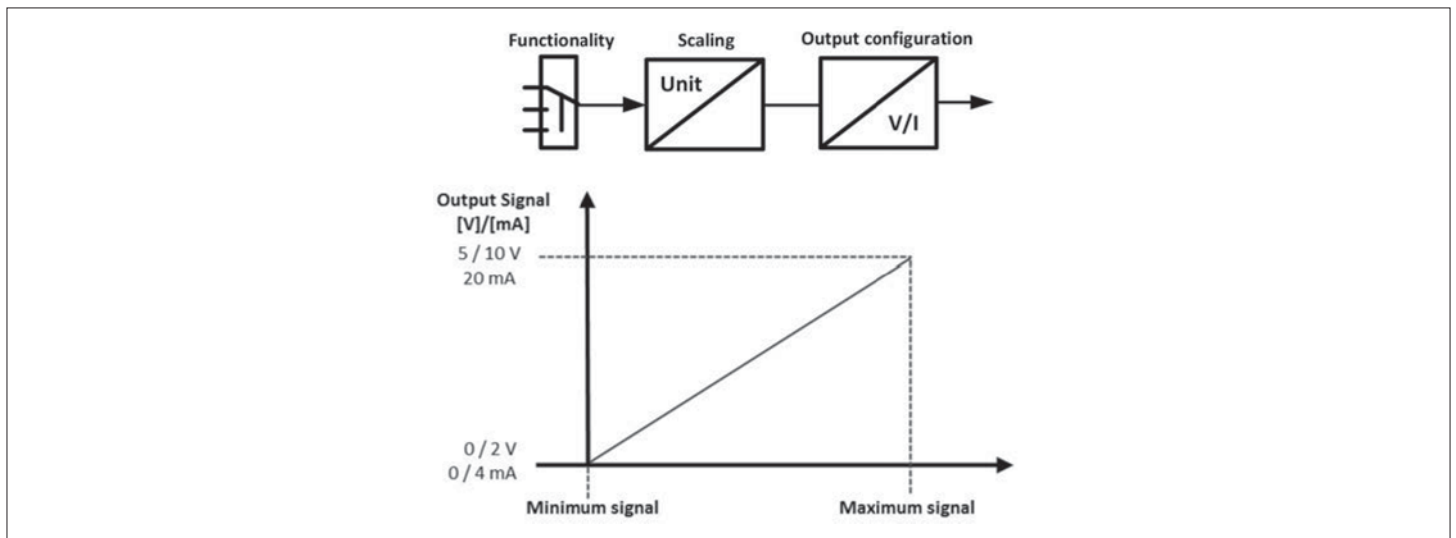

P440:1	0x2639:1	AO1 configuration			
0: Disabled 1: 0...10VDC 2: 0...5VDC 3: 2...10VDC 4: 4...20mA 5: 0...20mA		Configuration of Analog output signal 1			
P440:2	0x2639:2	AO1 function			
0: Not active 1: Output frequency 2: Frequency setpoint 3: Analog input 1 4: Analog input 2 5: Motor current 6: Output power 7: Torque actual value 10: Sequencer controlled 20: NETWordIN3 21: NETWordIN4		Analog output function1 Scaling factors: 1: [0.1 Hz] 2: [0.1 Hz] 3: [0.1 %] 4: [0.1 %] 5: [0.1 A] 6: [0.001 kW] 7: [0.1 %] 10: [0.01 V] 20: [0.1 %] 21: [0.1 %]			
P440:3	0x2639:3	AO1 minimum signal			
-- ... [0] ... --		Minimum scaling of the analog output 1 Setting x Scaling factor = Minimum analog output value: Example: Setting 10, 'Actual output frequency' Minimum analog output value = 10 x 0.1 Hz = 1Hz			
P440:4	0x2639:4	AO1 maximum signal			
-- ... [1000] ... --		Maximum scaling of the analog Output 1 Setting x Scaling factor = Maximum analog output value: Example: Setting 500, 'Actual output frequency' Maximum analog output value = 500 x 0.1 Hz = 50Hz			

5.6.16 PRESET SETPOINTS (FREQUENCY, PID, TORQUE)

The VSD has 15 preset frequency setpoints, 8 preset PID setpoints, 8 preset torque setpoints. They can be selected in two ways:

- As default setpoint (Frequency: P201:1, PID: P201:2, Torque: P201:3)
- Triggered by digital inputs (P400:18 – 400:21)

The Preset setpoint selection is done by a binary combination of bits triggering the Preset Setpoint Selection Functions. Combination Example: bit0 and bit2 result in Preset 6

➔ See chapter "5.6.2 Setpoint selection"

P450:1	0x2911:1	Frequency preset 1			
0.0 ... [20.0] ... 599.0 Hz		Frequency setpoint 1			
P450:2	0x2911:2	Frequency preset 2			
0.0 ... [40.0] ... 599.0 Hz		Preset frequency setpoint 2			
P450:3	0x2911:3	Frequency preset 3			
0.0 ... [Type code dependent] ... 599.0 Hz		Preset frequency setpoint 3			
P450:4	0x2911:4	Frequency preset 4			
0.0 ... [0.0] ... 599.0 Hz		Preset frequency setpoint 4			
P450:5	0x2911:5	Frequency preset 5			
0.0 ... [0.0] ... 599.0 Hz		Preset frequency setpoint 5 Note: Also used for Jog FWD			
P450:6	0x2911:6	Frequency preset 6			
0.0 ... [0.0] ... 599.0 Hz		Preset frequency setpoint 6 Note: Also used for Jog REV			
P450:7	0x2911:7	Frequency preset 7			
0.0 ... [0.0] ... 599.0 Hz		Preset frequency setpoint 7			
P450:8	0x2911:8	Frequency preset 8			
0.0 ... [0.0] ... 599.0 Hz		Preset frequency setpoint 8			
P450:9	0x2911:9	Frequency preset 9			
0.0 ... [0.0] ... 599.0 Hz		Preset frequency setpoint 9			
P450:10	0x2911:10	Frequency preset 10			
0.0 ... [0.0] ... 599.0 Hz		Preset frequency setpoint 10			
P450:11	0x2911:11	Frequency preset 11			
0.0 ... [0.0] ... 599.0 Hz		Preset frequency setpoint 11			
P450:12	0x2911:12	Frequency preset 12			
0.0 ... [0.0] ... 599.0 Hz		Preset frequency setpoint 12			
P450:13	0x2911:13	Frequency preset 13			
0.0 ... [0.0] ... 599.0 Hz		Preset frequency setpoint 13			
P450:14	0x2911:14	Frequency preset 14			
0.0 ... [0.0] ... 599.0 Hz		Preset frequency setpoint 14			
P450:15	0x2911:15	Frequency preset 15			
0.0 ... [0.0] ... 599.0 Hz		Preset frequency setpoint 15			
P451:1-8	0x4022:1-8	Process controller preset 1-8			
-300.00 ... [0.00] ... 300.00 PUnit		Preset PID setpoint 1-8			
P452:1-8	0x2912:1-8	Torque preset 1-8			
-400.00 ... [100.0] ... 400.0 %		Preset torque setpoint 1-8 – 100% = motor rated torque (P325:0) – Available from version 4.1.			

5.7 GROUP 5 – FIELDBUS

➔ For information regarding the fieldbus parameters refer to the communication manual of VLB3 instruction I488, downloadable from the website www.LovatoElectric.com.

5.8 GROUP 6 – PID SETUP

By means of the process controller, a process variable can be regulated, for instance the pressure of a pump. The process controller is also referred to as "PID controller" (PID controller = proportional, integral and differential controller). The process controller is part of a closed control loop. The variable to be influenced (controlled variable) is measured continuously by means of a sensor and supplied to the VSD as an analog signal (actual value) which, in the VSD, is then compared to the reference value (setpoint). The system deviation resulting therefrom is supplied to the process controller which, on this basis, decelerates or accelerates the motor speed according to the desired dynamic performance of the control loop, so that, for instance, a pump always generates the desired pressure.

Connection plan (example)

The following sample connection plan shows the control of a pump ①. The feedback of the variable (here: pressure) takes place via a pressure transducer ② connected to the analog input 1.

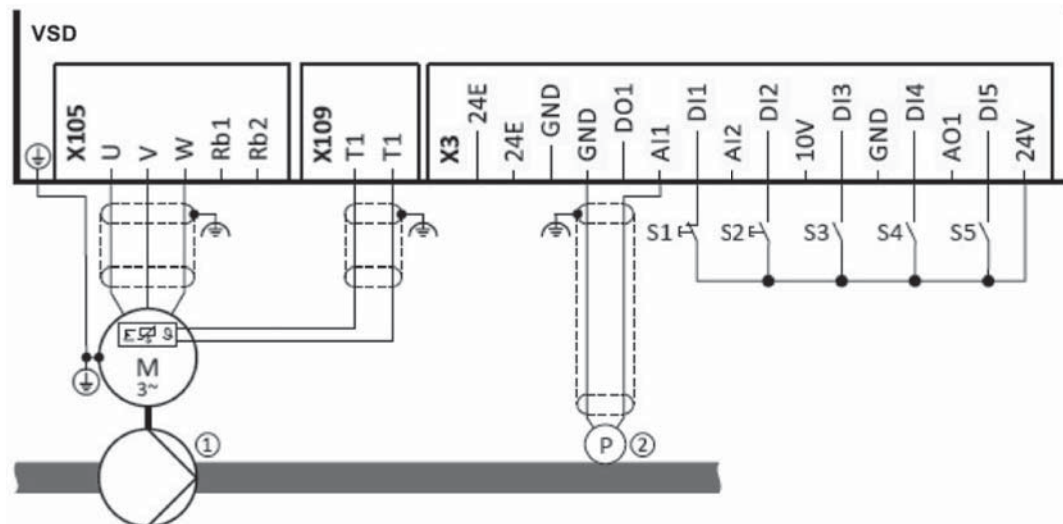

The digital inputs can be used to activate functions of the process controller. The specific assignment of the digital inputs and type of the contacts (switches or buttons, normally-closed contacts or normally-open contacts) depends on the application.

Basic process controller settings

The process controller is set in two steps:

1. Basic settings
2. Fine adjustment of the PID controller for an optimum control mode

Basic settings

Based on the default setting, we recommend the following proceeding:

- Activate PID control: Set the desired operating mode (normal or reverse operation) in P600:1.
- If the feedback of the variable is to take place via analog input 2 instead of analog input 1: Set P600:2 = "analog input 2 [2]".
- Configure used analog input:
 - Configure input range.
 - Configure setting range for the PID control.
 - Adapt filter time to minimise impacts of the noise on the variable.
 - Set monitoring response to "No response [0]".
- If a (temporary) change-over to a speed-controlled operation is to be possible via a digital input:
 - Assign a free digital input to the control function "Deactivate PID controller" in P400:45. As long as the digital input provides a TRUE signal, the PID control is ignored and the motor is driven in a speed-controlled way.
 - Set acceleration time P606:1 and deceleration time P606:2 for speed-controlled drive control.
- Select the standard setpoint source for the reference value in P201:2.
 - Functions for setpoint change-over can be used as well.
 - The keypad setpoint can be preset in P202:2.
 - If process controller presets are used, they have to be set in P451:1 ...P451:8.
 - If the analog input is used as setpoint source, it must be configured accordingly.
 - If the motor potentiometer is used as setpoint source, this function must be configured accordingly.
- Set the speed range to be controlled in P600:3.
- If the output value of the process controller is to be limited, adapt the following parameters:
 - P600:5: Min speed limit
 - P600:6: Max speed limit
- Try out the following parameters with the default setting and only adapt them if required:
 - P604:0: Setpoint ramp
 - P607:1: Acceleration time for showing the process controller influence
 - P607:2: Deceleration for hiding the process controller influence
- Diagnostics: Check current reference value and feedback of the variable:
 - The current reference value (setpoint) is displayed in P121:1.
 - The current variable (actual value) is displayed in P121:2.

After the basic setting of the process controller has been carried out, a fine adjustment of the PID controller must be executed for an optimum control mode (see the following section).

Fine adjustment of the PID controller

The dynamics of the PID controller is parameterised based on the gain of the P component P601:0, the reset time for the I component P602:0 and the gain of the D component P603:0. In the default setting, the process controller operates as PI controller, the D component is deactivated.

Basics

- If only the P component is used and the system operates in a steady-state status (reference value is constant and process variable is controlled to a fixed value), a certain system deviation always continues to exist. This remaining system deviation is also called "stationary deviation".
- The I component ensures that no permanent system deviation remains. Here, the reset time P602:0 determines how much the duration of the control deviation influences the control. A high reset time means a lower influence of the I component and vice versa.
- The D component does not respond to the height of the system deviation but to their rate of change only. The D component acts as a "damper" for overshoots. Overshoots may occur if the control tries to respond quickly to changes in the system deviation or the reference value. Thus, the D component reduces the risk of instabilities due to overshoots.

i For most applications, the setting of the gain of the P component and the reset time for the I component is sufficient for the fine adjustment. The setting of the gain of the D component may be required for a further stabilisation of the system especially if a quick response to system deviations is to take place.

Execute fine adjustment:

1. Set the reset time for the I component to 6000 ms in P602:0 to deactivate the I component.
 - With this setting and the default setting of P603:0, the process controller operates as P controller.
2. Increase gain of the P component step by step in P601:0 until the system gets instable.
3. Reduce gain again until the system is stable again.
4. Reduce gain by another 15 %.
5. Set reset time for the I component P602:0.
 - With this setting it should be noted that a too low reset time may cause overshoots, especially in case of high steps of the system deviation.
6. Set optional gain of D component in P603:0.
 - With this setting it should be noted that the D component responds very sensitively to electrical disturbance on the feedback as well as digitisation errors.

5.8.1 PID SETUP

P600:1	0x4020:1	Operating mode			
0: Disabled 1: Normal operation 2: Reverse operation 3: Normal bi-directional 4: Reverse bi-directional		PID Operating mode 0: Disabled: PID is disabled 1: Normal operation Direct acting system. Motor needs to increase the speed to increase the feedback signal. Example: Booster pump regulated by Pressure. (Increase of Motor speed results in an increase of the pressure) Motor can turn only in one direction 2: Reverse operation Motor needs to increase the speed to decrease the feedback signal. Example: Cooling water pump regulated by temperature. (Increase of the cooling pump speed results in a decrease of the temperature.) Motor can run only in one direction 3: Normal bi-directional Normal acting mode. Motor can run in both directions. 4: Reverse bi-directional Reverse acting mode. Motor can run in both directions.			
P600:2	0x4020:2	Feedback source			
1: Analog input 1 2: Analog input 2 3: DC Bus voltage 4: Motor Current 5: Network 6: HTL input		Selection of the PID feedback source Note: The PID set point and PID Feedback can be different signals!			
P600:3	0x4020:3	Controlled speed range			
0 ... [100] ... 100 %		Defines the % of the VSD output frequency that PID will regulate to. Example: P211:0 Max frequency = 50 Hz P600:3 PID Controlled speed range = 80 % --> Max calculated PID setpoint 40 Hz			
P600:4	0x4020:4	Speed feedforward source			
0: No Speed Added 1: Keypad frequency setpoint 2: Analog input 1 3: Analog input 2 4: Preset frequency setpoint 1 5: Preset frequency setpoint 2 6: Preset frequency setpoint 3 7: Preset frequency setpoint 4 8: Network		Selection of Speed feedforward source PID speed output = Speed feedforward source + PID controlled speed (Used for Trim control, Dancer control). The line speed (feed-forward) value is added to the calculated PID output frequency value (see PID block diagram above).			
P601:0	0x4048:0	P component gain			
0.0 ... [5.0] ... 1000.0 %		PID controller P gain % of max Frequency that results from a 1% PID Error Example: PID Error = 20 PUnits P601:0 P component gain = 2% P211:0 Maximum frequency = 50Hz --> PID Output = PID Error * P Gain * (Maximum frequency / 100) --> PID Output = 10 Hz			
P602:0	0x4049:0	I component reset time			
20 ... [400] ... 6000 ms		PID controller adjustment time Tn - Value "6000 ms" deactivates the I component. - With P400:47 the I Part can be disabled			

P603:0	0x404A:0	D component gain			
0.0 ... [0.0] ... 20.0 s		PID controller D gain % of max Frequency that results from 1%/s change of the PID Error			
P604:0	0x404B:0	Setpoint ramp (PID)			
0.0 ... [20.0] ... 100.0 s		PID Setpoint ramp up/down time (Time from Analog Min to Analog Max)			

5.8.2 PID FUNCTION SELECTION

P400:45	0x2631:45	Deactivate PID control			
0:Not connected (Reference see P400:1)		Switch off PID controller by external trigger Trigger=TRUE: if PID control is activated, ignore PID control and drive the motor in speed-controlled manner. Trigger=FALSE: if PID control is activated, drive the motor with PID control. Note. The PID control mode can be selected in P600:1.			
P400:46	0x2631:46	PID output forced to 0			
0:Not connected (Reference see P400:1)		Switch off PID controller output to zero State: TRUE: The output of the PID controller is forced to 0. FALSE: No action			
P400:47	0x2631:47	PID integrator disabled			
0:Not connected (Reference see P400:1)		Disable PID I-component (integrator) by external Trigger			

5.8.3 PID SPEED LIMITS

P600:5	0x4020:5	PID minimum speed limit			
-100.0 ... [-100.0] ... 100.0 %		- 100% = maximum frequency (P211:0) - The limitation becomes effective after the line speed has been added - The value set here also limits the I component of the PID (Integrator-Anti-Windup)			
P600:6	0x4020:6	PID maximum speed limit			
-100.0 ... [100.0] ... 100.0 %		Maximum output value of the process controller - 100% = maximum frequency (P211:0) - The limitation becomes effective after the line speed has been added. - The value set here also limits the I component of the PID (Integrator-Anti-Windup)			

5.8.4 PID SETPOINT LIMITS

P605:1	0x404E:1	Minimum setpoint			
-300.00 ... [-300.00] ... 300.00 PUnit		Minimum limitation of the PID setpoint			
P605:2	0x404E:2	Maximum setpoint			
-300.00 ... [300.00] ... 300.00 PUnit		Maximum limitation of the PID setpoint			

5.8.5 PID ACCELERATION / DECELERATION

P606:1	0x4021:1	Acceleration time			
0.0 ... [1.0] ... 3600.0 s		PID output Acceleration time (Time from 0 to Maximum frequency)			
P606:2	0x4021:2	Deceleration time			
0.0 ... [1.0] ... 3600.0 s		PID output Deceleration time (Time from Maximum frequency)			

5.8.6 PID INFLUENCE

The Influence of the PID can be ramped up / down with a external Trigger.
Example usage: winding application.

P400:48	0x2631:48	Activate PID influence ramp			
1:Constant TRUE (Reference see P400:1)		Assignment of a trigger for the "Activate PID influence ramp" function. Trigger = TRUE: the influence of the process controller is shown via a ramp. Trigger = FALSE or not connected: the influence of the process controller is hidden via ramp. Notes: – The influence of the process controller is always active (not only when PID control is activated). – Acceleration time for showing the influence of the process controller can be set in P607:1. – Deceleration time for hiding the influence of the process controller can be set in P607:2.			
P607:1	0x404C:1	Ramp up time			
0.0 ... [5.0] ... 999.9 s		Ramp up time during switch ON of influencing (P400:48 PID influence ramps active) (Time from 0 to Maximum frequency)			
P607:2	0x404C:2	Ramp Down Time			
0.0 ... [5.0] ... 999.9 s		Ramp down time during switch OFF of influencing (P400:48 PID influence ramps active) (Time from Maximum frequency to 0)			

5.8.7 PID ALARMS

P608:1	0x404D:1	MIN alarm threshold			
-300.00 ... [0.00] ... 300.00 PUnit		Minimum alarm of PID feedback signal If PID feedback signal is lower than Min alarm level the signal is activated. Signal can be used to switch Digital Output / Relays / Network Output (Selection 75-77)			
P608:2	0x404D:2	MAX alarm threshold			
-300.00 ... [100.00] ... 300.00 PUnit		Maximum alarm of PID feedback signal If PID feedback signal is high than Min alarm level the signal is activated. Signal can be used to switch Digital Output / Relays / Network Output (Selection 75-77)			
P608:3	0x404D:3	Monitoring bandwidth PID feedback signal			
0.00 ... [2.00] ... 100.00 % (from V4.1)		Hysteresis for status signal "PID feedback = setpoint [73]" – 100% = configured variable input range – Example: variable input range 0...10V → 2% = 0,2V – The status signal "PID feedback = setpoint [73] is TRUE if the controlled variable feedback = process controller setpoint (±hysteresis set here)			

5.8.8 PID IDLE (SLEEP) AND RINSE FUNCTION

The PID has an integrated sleep & rinse function.

- Sleep function: Stop PID if there is no demand from the process
- Rinse function: Start the VSD periodically during sleep mode to prevent accumulation of deposits in the piping or the pump system.

Process controller idle state

If the PID control is activated, this function sets the drive in process controller mode to an energy-saving idle state when no power is required.

A typical application for this function is a booster pump for water in a high-rise building. If no tenant opens the water tap or uses the shower for a longer period of time, the pump changes to the energy-saving idle state. This usually happens at night. The idle state automatically ends as soon as a tenant opens the tap again. The pumps operates normally again until the condition for the idle state is pending again.

The conditions for activating and terminating the idle state can be set independently of one another:

- P610:1 : Condition for activating the idle state.
- P610:6: Condition for terminating the idle state.

P610:1	0x4023:1	PID sleep mode: Activation			
0: Disabled 1: Setpoint < threshold 2: Setpoint < threshold OR process variable > feedback threshold 3: Setpoint < threshold OR process variable < feedback threshold		Selection of the condition for activating the idle state. 0: Disabled Idle state deactivated. 1: Setpoint < threshold Activation of idle state if frequency setpoint P102:0 < frequency threshold P610:3 longer than the deceleration time P610:5. 2: Setpoint < threshold OR process variable > feedback threshold Activation of idle state if – Frequency setpoint P102:0 < frequency threshold P610:3 longer than the deceleration time P610:5 OR – Feedback variable P121:2 > feedback threshold P610:4 longer than the deceleration time P610:5. 3: Setpoint < threshold OR process variable < feedback threshold Activation of idle state if – Frequency setpoint P102:0 < frequency threshold P610:3 longer than the deceleration time P610:5 OR – Feedback variable P121:2 < feedback threshold P610:4 longer than the deceleration time P610:5.			

P610:2	0x4023:2	PID sleep mode: Stop method			
0: Coasting 1: Deceleration to standstill 2: Stop method set		Selection of the stop method after activation of the idle state. 0: Coasting The motor becomes torqueless (coasts down to standstill). 1: Deceleration to standstill The motor is brought to a standstill with deceleration time 1 (or deceleration time 2, if activated). – Deceleration time 1 can be set in P221:0. – Deceleration time 2 can be set in P223:0. 2: Stop method set The stop method set in P203:3 is used.			
P610:3	0x4023:3	PID sleep mode: Frequency threshold			
0.0 ... [0.0] ... 599.0 Hz		Frequency threshold for the activation of the idle state. For comparing "output frequency < frequency threshold P610:3" in case of selection 1 ... 3 in P610:1.			
P610:4	0x4023:4	PID sleep mode: Feedback threshold			
-300.00 ... [0.00] ... 300.00 PID unit		Feedback threshold for the activation of the idle state. – For comparing "feedback variable > feedback threshold P610:4 in case of selection 2 in P610:1. – For comparing "feedback variable < feedback threshold P610:4 in case of selection 3 in P610:1.			
P610:5	0x4023:5	PID sleep mode: Delay time			
0.0 ... [0.0] ... 300.0 s		Minimum time for which the respective threshold must be underrun or exceeded before the idle state is activated.			
P610:6	0x4023:6	PID sleep mode: Recovery			
0: Setpoint > threshold OR system deviation > bandwidth 1: Process variable < recovery threshold 2: Process variable > recovery threshold		Selection of the condition for terminating the idle state. 0: Setpoint > threshold OR system deviation > bandwidth Completion of idle state if – frequency setpoint P102:0 > (frequency threshold P610:3 + 2 Hz hysteresis) OR – in case of active PID control system deviation > bandwidth P610:7 and bandwidth P610:7 ≠ 0. 1: Process variable < recovery threshold Completion of idle state if the controlled variable feedback P121:2 < completion threshold P610:8. 2: Process variable > recovery threshold Completion of idle state if the controlled variable feedback P121:2 > completion threshold P610:8.			
P610:7	0x4023:7	PID sleep mode: Bandwidth			
0.00 ... [0.00] ... 300.00 PID unit		Range around the process controller setpoint for terminating the idle state. 0.00 = Bandwidth deactivated.			
P610:8	0x4023:8	PID sleep mode: Recovery threshold			
-300.00 ... [0.00] ... 300.00 PID unit		Termination threshold for idle state.			

Process controller rinse function

This function accelerates the motor in idle state of the process controller at regular intervals to a defined speed.

A typical application for this function is the rinsing of a pipe system with a pump that has been in an inactive state for a longer period to prevent deposits.

- In order to activate the rinsing function, set the selection "Enabled [1]" in P615:1.
- The following diagram demonstrates the function:

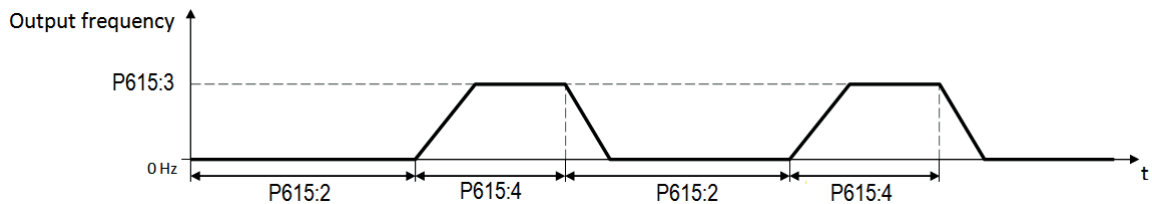

P615:1	0x4024:1	Automatic rinsing: Rinsing in idle state			
0: Inhibited 1: Enabled		1 = activate automatic rinsing in idle state.			
P615:2	0x4024:2	Automatic rinsing: Rinse interval			
0.0 ... [30.0] ... 6000.0 min		Time interval between two rinsing processes.			
P615:3	0x4024:3	Automatic rinsing: Rinse speed			
-599.0 ... [0.0] ... 599.0 Hz		Speed setpoint for rinse function.			
P615:4	0x4024:4	Automatic rinsing: Rinse period			
0.0 ... [0.0] ... 6000.0 s		Duration of a rinsing process.			

5.9 GROUP 7 – AUXILIARY FUNCTIONS

5.9.1 RESET PARAMETERS TO DEFAULT

With the "Load default settings" device command, all parameters can be reset to the default setting.

i By executing this device command, all parameter settings made by the user are lost!

Details

– All current parameters in the RAM memory of the VLB3 are overwritten by the default parameters stored in the firmware of the drive. (The persistent parameters in the memory module remain unaffected by this measure.)

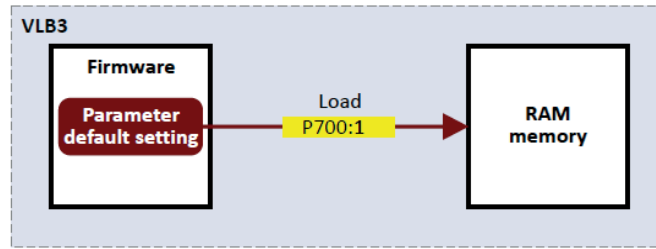

Afterwards the VLB3 can be parameterised again on the basis of this initial state.

- Typical application: incorrect or unknown parameter settings.
- The device command only has an effect on the RAM. For a permanent acceptance of the changes made, the data must subsequently be saved in the memory module. → See chapter "Saving/loading the parameter settings".

P700:1	0x2022:1	Device commands: Load default settings
0: Off / ready 1: On / start 2: In progress 3: Action cancelled 4: No access 5: No access (VSD disabled)		1 ≙ reset all parameters in the RAM memory of the VSD to the default setting that is stored in the VSD firmware. – All parameter changes made by the user are lost during this process! – It may take some seconds to execute the task. When the task has been executed successfully, the value 0 is shown. – Loading parameters has a direct effect on the cyclic communication: The data exchange for control is interrupted and a communicationerror is generated. – Setting can only be changed if the VSD is inhibited.

5.9.2 SAVING/LOADING THE PARAMETER SETTINGS

If parameter settings of the VSD are changed, these changes at first are only made in the RAM memory of the VSD. In order to save the parameter settings with mains failure protection, the VSD is provided with a pluggable memory module and corresponding device commands.

Details

The memory module is provided with two memories, the user memory and the OEM memory.

User memory

The user memory is used as power-failure-proof storage of parameter settings made by the user during commissioning/operation.

- The SET display blinks on the keypad if a parameter setting has been changed but has not been saved in the memory module with mains failure protection. In order to save parameter settings in the user memory of the memory module, press and hold the keypad "Enter" key for longer than 3 s.

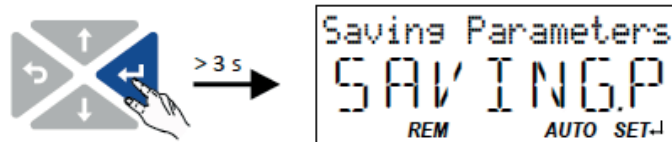

- Parameter settings carried out with VLBXSW01 software or via network must be explicitly saved in the user memory by means of the "Save user data" device command, so that the changes carried out are not lost when the mains of the VSD are switched.
- Saving can also be made in the VLBXSW01 software via the button  or the <F6> function key.
- The device command "Load user data" serves to reload the data from the user memory into the RAM.

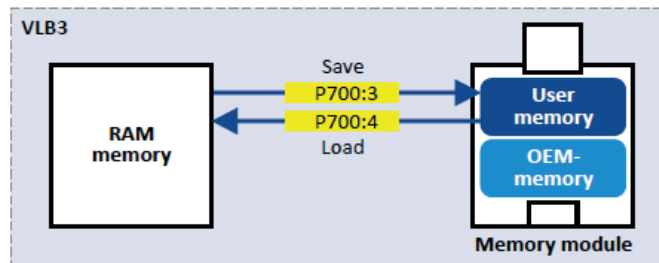

OEM memory

The OEM memory is provided for the storage of customised parameter settings by the OEM/ mechanical engineer. If the user carries out parameter settings with the keypad, they are always saved in the user memory if the keypad Enter key is pressed longer than 3 s. The OEM memory remains unaffected by these changes.

- With the "Load OEM data" device command, the parameter settings preconfigured by the OEM/mechanical engineer can be reloaded to the RAM memory of the VSD at any time if required.
- For saving parameter settings in the OEM memory, the "Save OEM data" device command must be executed explicitly. The parameter settings are simultaneously saved in the user memory.

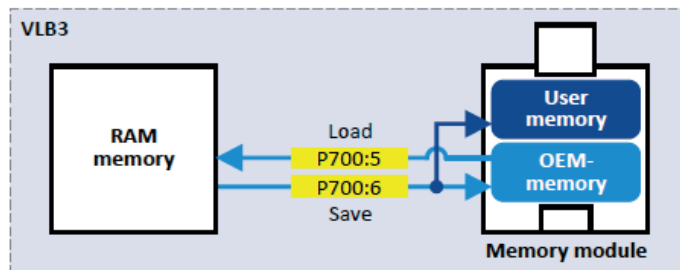

Response after initial switch-on of the VSD

After switch-on, the VSD first tries to load the parameter settings stored in the user memory.

If the user memory is empty or damaged, an error message is output and the user must intervene:

- Case 1 = user memory empty: → default setting is loaded automatically from the firmware → data are saved automatically in the user memory of the memory module.
- Case 2 = user memory damaged: → Error message → default setting is loaded automatically → data are saved automatically in the user memory of the memory module.
- Case 3 = OEM memory empty/damaged: → error message → data are loaded automatically from the user memory of the memory module.

Parameter

P700:3	0x2022:3	Save user data			
0: Off / ready 1: On / start 2: In progress 3: Action cancelled 4: No access 5: No access (VSD disabled)		1 = save current parameter settings in the user memory of the memory module with mains failure protection. – It may take some seconds to execute the task. When the device command has been executed successfully, the value 0 is shown. – Do not switch off the supply voltage during the saving process and do not unplug the memory module from the VSD! – When the VSD is switched on, all parameters are automatically loaded from the user memory of the memory module to the RAM memory of the VSD.			
P700:4	0x2022:4	Load user data			
0: Off / ready 1: On / start 2: In progress 3: Action cancelled 4: No access 5: No access (VSD disabled)		1 = load data from the main memory of the memory module to the RAM memory of the VSD. – When the device command has been executed successfully, the value 0 is shown. – Loading parameters has a direct effect on the cyclic communication: The data exchange for control is interrupted and a communication error is generated.			
P700:5	0x2022:5	Load OEM data			
0: Off / ready 1: On / start 2: In progress 3: Action cancelled 4: No access 5: No access (VSD disabled)		1 = load data from the OEM memory of the memory module to the RAM memory of the VSD. – When the device command has been executed successfully, the value 0 is shown. – Loading parameters has a direct effect on the cyclic communication: The data exchange for control is interrupted and a communication error is generated.			
P700:6	0x2022:6	Save OEM data			
0: Off / ready 1: On / start 2: In progress 3: Action cancelled 4: No access 5: No access (VSD disabled)		1 = save current parameter settings in the OEM memory of the memory module with mains failure protection. – At the same time, the parameter settings are saved in the main memory of the memory module. – When the device command has been executed successfully, the value 0 is shown.			

5.9.3 KEYPAD SETUP

P701:0	0x2862:0	Keypad setpoints			
1 ... [1] ... 100		Defines the setpoint increment by pressing UP/DOWN buttons on the keypad. Preset increments: Frequency = 0.1 Hz, PID = 0.01 Punit, Torque = 1%			
P702:0	0x4002:0	Speed display scaling			
0.00 ... [0.00] ... 650.00		User unit can be shown on the keypad during running of the motor. (Example: Calculated speed after gearbox) The scaling factor P702:0 defines the user unit: User unit = "Actual frequency" x P702:0 The scaled user unit is also shown in P101:0 (0x400D:0) Note: 0: Function disabled In PID mode the user unit has to be selected setting P703:0 to the scaled user unit (Set P703:0 = 0x400D0000)			
P703:0	0x2864:0	Keypad display			
0x0 ... [0x0] ... 0xFFFFF00		The parameter which is shown on the keypad during running of the motor can be configured. Format: 0xiiiiss00 (iii = Index heximal, ss=subindex) Note: 0: Function disabled Only parameters from group 1 can be selected.			
P705:0	0x2863:0	Keypad language selection			
0: No Language 1: English 2: German		Selects the language of the Keypad			

P708:1	0x2602:1	Keypad setup: CTRL & F/R key setup			
0: CTRL & F/R Disable 1: CTRL & F/R Enable 2: CTRL Enable F/R Disable 3: CTRL Disable F/R Enable		Disable/enable CTRL and F/R key of the keypad. Available from version 4.1			
P708:2	0x2602:2	Keypad setup: Keypad rotation setup			
0: Forward 1: Reverse		Instructed direction of rotation if local keypad control is active. – If the local keypad control is active, this setting can be directly changed via the keypad key R-F if the key in P708:1 has not been disabled. – When the remote control is changed over to local keypad control and vice versa, this parameter is set to "Forward [0]". Available from version 4.1			
P708:3	0x2602:3	Keypad setup: Keypad Full Control			
0: Off 1: On		Activate/deactivate full keypad control. – This setting can be changed directly via the keypad key CTRL if the key in P708:1 has not been disabled. – When the control mode is changed over, the motor is stopped and the "Forward" direction of rotation is set. Available from version 4.1			

5.9.4 DELETE LOGBOOK

P700:15	0x2022:15	Device commands: Delete logbook			
0: Off / ready 1: On / start		1 = delete all entries in the logbook. Setting can only be changed if the VSD is inhibited.			

5.9.5 WIRELESS LAN (WLAN)

The pluggable Wi-Fi module VLBXC03 enables:

- an easy access to VSDs that are installed in difficult access areas,
- an easy parameter setting without cable and instead of the keypad,
- a comfortable monitoring and adaptation of the machine.







The VSD can be accessed via WLAN with the VLBXSW01 software.

VLBXC03 is compatible with VSD with firmware version \geq 4.1.

5.9.5.1 WLAN LED status displays

Information on the Wi-Fi module VLBXC03 status can be obtained quickly via the LED displays "Power", "TX/RX" and "WLAN" on the front of the Wi-Fi module.

The meaning can be seen from the table below.

LED "Power" /green)	LED "TX/RX" (yellow)	LED "WLAN" (green)	Status/meaning
off	off	off	No supply voltage
			Self-test (duration approx. 1 s)
on	on	on	Ready for operation - no active WLAN connection
	off	off	Communication active
			Communication active
	Flashing	on	Communication active
	off		Client mode - waiting for connection
off	off	blinking	Client mode - waiting for connection
	off	off	Trouble
blinking	off	off	Trouble

i After being plugged in, the Wi-Fi module needs approx. 20 seconds until it is ready for operation.

5.9.5.2 WLAN basic settings

The WLAN functionality can be configured via the following parameters.

- The WLAN module can be connected and removed during operation.
- The WLAN module can either create an own WLAN network (access point mode, default setting) or implement itself as a WLAN client in an already existing WLAN network. For details see the following subchapters.
- The WLAN connection is encrypted. The WLAN encryption can be selected in 0x2441:9.
- 0x2441:12 can be used to set that the name of the WLAN network, called SSID, is not visible for other WLAN devices. As a result, the number of WLAN networks displayed on PC can be reduced.
- Two data sources are possible for the WLAN settings: VSD and WLAN module.
 - Data source - VSD: The WLAN settings saved in the VSD are used. Each VSD has its own WLAN settings.
 - Data source - WLAN module: The WLAN settings saved in the WLAN module are used.
- In this "stand-alone" mode, the WLAN module can be plugged onto another VSD and then be used with the same settings (irrespective of the WLAN settings of the VSD).
- The data source is activated with 0x2440.
- The currently active data source is displayed in 0x2442:4.

-	0x2440	Initiate WLAN			
0: No action / no error 1: Restart with current values 2: Restart with default values 11: Restart with current values		Restart WLAN network with default setting or current settings. 0: No action / no error Only status display. 1: Restart with current values Restart WLAN network with current settings of the WLAN parameters. The WLAN settings of the active data source (VSD or WLAN module) are used. - The active data source is displayed in 0x2442:4. - The data source is not changed by this selection. 2: Restart with default values Restart WLAN network with default setting of the WLAN parameters. - The WLAN settings saved in the WLAN module are deleted. - Active data source for the WLAN settings is now the VSD. 11: Restart with current values Restart WLAN network with current settings of the WLAN parameters. - The current settings are saved in the WLAN module. - Active data source for the WLAN settings is now the WLAN module.			
-	0x2441:4	WLAN settings: DHCP			
0: Disabled 1: Enabled		1 = Dynamic Host Configuration Protocol (DHCP) is enabled. - In the access point mode, the DHCP server of the WLAN module is activated. - In the client mode, the DHCP-client function is activated.			
-	0x2441:5	WLAN settings: DHCP start address			
0 ... [0] ... 4294967295		Definition of the start address when the Dynamic Host Configuration Protocol (DHCP) is used. - Only relevant for access point mode. - When 0 is set, the active IP address + 1 is used as start address.			
-	0x2441:6	WLAN settings: WLAN operation mode			
0: Access point mode 1: Client mode		Definition of the operating mode of the WLAN module. 0: Access point mode For a direct connection to another WLAN device, the WLAN module creates an own WLAN network. 1: Client mode The WLAN module can be integrated as WLAN client into an already existing WLAN network.			
-	0x2441:7	WLAN settings: WLAN SSID			
		Name (Service Set Identifier, SSID) of the WLAN network.			
-	0x2441:8	WLAN settings: WLAN password			
["password"]		Password (WLAN network key) of the WLAN network. - This password serves to secure the WLAN connections. - The password must have a minimum length of 8 digits.			
-	0x2441:9	WLAN settings: WLAN security			
0: WPA 1: WPA2		Selection of the WLAN encryption.			
-	0x2441:10	WLAN settings: WLAN access			
0: Disabled 1: Enabled		Switch on/off WLAN.			
-	0x2441:11	WLAN settings: WLAN channel			
1: Channel 1 2: Channel 2 ... 11: Channel 11		Selection of the WLAN channel.			
-	0x2441:12	WLAN settings: WLAN SSID broadcast			
0: Activated 1: Deactivated		1 = the name of the WLAN network, called SSID, is not visible for other WLAN devices.			
-	0x2442:4	Active WLAN settings: Active module mode			
Read only 0: VSD 1: Stand alone		Display of the active data source for the WLAN settings. This parameter indicates whether the settings used come from the VSD or from the WLAN module. 0: VSD The WLAN settings saved in the VSD are used. 1: Stand alone The WLAN settings saved in the WLAN module are used.			
-	0x2442:5	Active WLAN settings: MAC address			
Read only		Display of the MAC address of the WLAN module.			
-	0x2449	WLAN error			
Read only Bit 2: WLAN error Bit 3: Memory problem Bit 4: WLAN connection problem Bit 7: WLAN off Bit 9: Client mode off Bit 12: TCP/IP configuration error Bit 13: Password length Bit 14: Access denied		Bit coded display of WLAN errors.			

5.9.5.2.1 Resetting WLAN settings to default setting

Possible reasons:

- Password is not known anymore.
- WLAN SSID is not visible and not known anymore.
- WLAN module mode 'stand-alone' shall be deactivated.

0x2440 serves to reset all WLAN settings to the default setting. For this purpose, the VSD must be connected to the VLBXSW01 software via the USB module (VLBXC02) or an existing network.

Option 1: Reset via USB module

Required accessories:

- USB module VLBXC02
- USB 2.0 cable (A-plug on micro B-plug)
- PC with installed VLBXSW01 software

1. Remove the WLAN module VLBXC03 from the VSD and plug on the USB module VLBXC02 instead.
2. Establish a connection between VSD and VLBXSW01 via the USB module.
3. Set the parameter 0x2440 to "Restart with default values [2]".

4. Remove the USB module from the VSD and plug on the WLAN module instead again.

The default setting is loaded.

Option 2: Reset via network

How to reset the WLAN settings to default setting via network:

Requirements:

- The VSD is ready for operation (supplied with voltage).
- The VSD is connected to a functioning network.

Required accessories:

- PC with installed VLBXSW01. Moreover, the PC must be connected to the network which also implements the VSD.

1. Establish a connection between the VSD and VLBXSW01 via the used network.
2. Set the parameter 0x2440 to "Restart with default values [2]".

The default setting is loaded.

5.9.5.3 WLAN access point mode

In the presetting, the WLAN module VLBXC03 is configured as WLAN access point because this is the most frequent application. In this operating mode, the WLAN module creates its own WLAN network for a direct connection to other WLAN devices.

The supported WLAN device is a PC (with WLAN functionality) and the VLBXSW01 software.

Details

- In default setting, every VSD with WLAN functionality comes with an individual network name, called SSID.
- In the default setting, the password for the WLAN network is called "password" and can be changed in 0x2441:8.

- i** If the WLAN module is to be plugged onto the VSD for a longer period of time, it is important to select a safe password. Otherwise, a potential attacker might connect to the WLAN access point and attack the device and other connected devices or networks. Currently (status: 2017), a WLAN is considered as safe if the password consists of more than 20 characters, contains capital and small letters, numbers and special characters and cannot be found in any dictionary.

The following illustration displays the SSIDs as examples only:

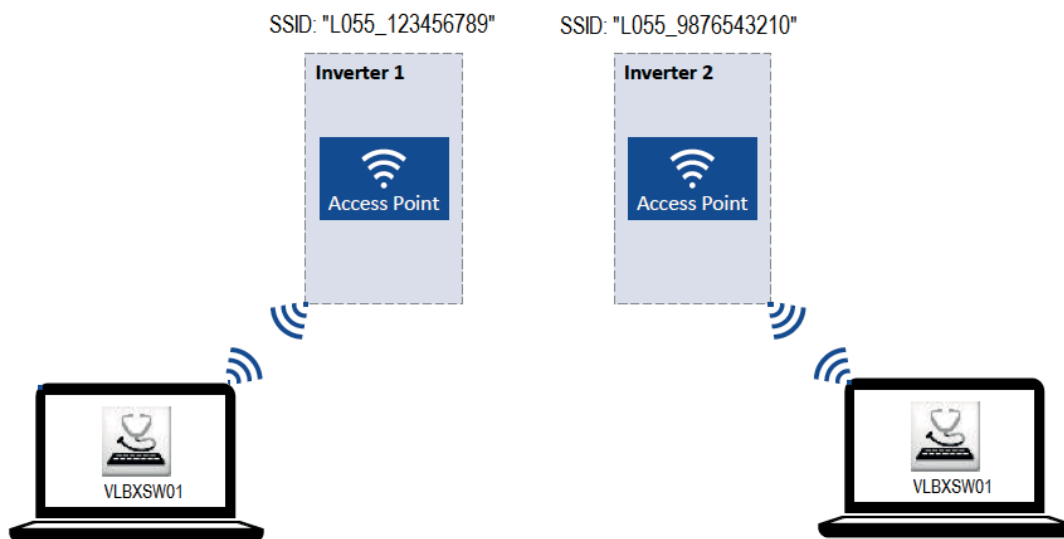

5.9.5.3.1 Establishing a direct WLAN connection between PC and VSD

Requirements

- The functional test described in the mounting and switch-on instructions has been completed successfully (without any errors or faults).
- The VSD is ready for operation (supplied with voltage).
- WLAN module VLBXC03 installed.
- PC (with WLAN functionality) and installed VLBXSW01 software.

1. Plug the WLAN module VLBXC03 onto the front of the VSD.
2. Open the network settings on the PC: "Control panel" → "Network and sharing center".
3. Select the "Set up a new connection or network" option under "Change your network settings". The "Set Up a Connection or Network" dialog box is displayed.
4. Select the "Manually connect to a wireless network" connection option and click the "Next" button. The "Manually connect to a wireless network" dialog box is displayed.
5. Enter the SSID of the VSD as network name.
6. Select "WPA2-Personal" as safety type.
7. Select "AES" as encryption type.
8. Enter the password as safety key for the WLAN network (default setting "password").
9. Tick "Start this connection automatically".
10. Click "Next". A note indicates that the connection has been added successfully.
11. Click "Close".
12. Start VLBXSW01 software.
The "Add devices" dialog is shown.
13. Select the connection "Wi-Fi module Lovato VLBXC03".
14. Click the Insert button.
VLBXSW01 searches for connected devices via the communication path selected.
When the connection has been established successfully, the VSD is displayed in the device list of VLBXSW01. The VSD parameters can now be accessed via the tabs of VLBXSW01.

5.9.5.4 WLAN client mode

The WLAN module VLBXC03 can be optionally configured as a WLAN client. In this operating mode, the WLAN module can be implemented into an already existing WLAN network.

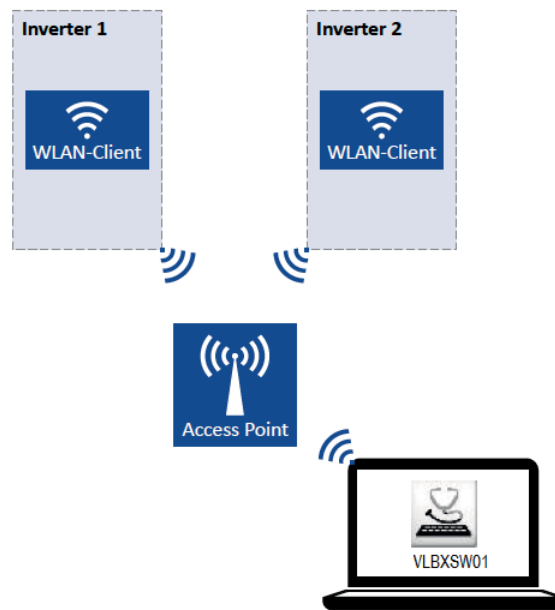

How to configure the WLAN module as WLAN client:

Requirements:

- The WLAN settings of the VSD can be accessed via VLBXSW01.
 - Name (SSID) and password of the external WLAN network are known.
1. Set the selection "Client mode [1]" in 0x2441:006.
 2. Set the name (SSID) of the external WLAN network in 0x2441:007.
 3. Set the password of the external WLAN network in 0x2441:008.
 4. Before activating the changed WLAN settings in the next step: Make sure that the name (SSID) and the password of the external WLAN network are set correctly. The restart of the WLAN module in the client mode causes a termination of an existing WLAN connection in the access point mode!
 5. Restart the VSD or remove and replug the WLAN module to activate the changed WLAN settings.
- The WLAN module now tries as a client to establish a connection to the set external WLAN network.

Notes:

- In the default setting, the WLAN client is configured as DHCP client in 0x2441:004.
- Settings as IP address, subnetwork mask and gateway are automatically made by the DHCP server of the external WLAN network.
- The active settings are displayed in 0x2442:001, 0x2442:002 and 0x2442:003.
- A static IP configuration can be made via the parameters 0x2441:001, 0x2441:002 and 0x2441:003.

-	0x2441:1	WLAN settings: IP address			
0 ... [28485824] ... 4294967295		Definition of the IP address for the WLAN access point. – In the client mode, a static IP address can be set here for the WLAN client. In order that the static configuration becomes effective, DHCP must be disabled in 0x2441:004. – Byte order is "Big-Endian": 192.168.178.01 ≡ 0x01B2A8C0 (= 28485824)			
-	0x2441:2	WLAN settings: Netmask			
0 ... [16777215] ... 4294967295		Definition of the network mask for the WLAN access point. – In the client mode, a static network mask can be set here for the WLAN client. In order that the static configuration becomes effective, DHCP must be disabled in 0x2441:004. – Byte order is "Big-Endian": 255.255.255.0 ≡ 0x00FFFFFF (= 16777215)			
-	0x2441:3	WLAN settings: Gateway			
0 ... [28485824] ... 4294967295		Definition of the gateway for the WLAN access point. – In the client mode, a static gateway can be set here for the WLAN client. In order that the static configuration becomes effective, DHCP must be disabled in 0x2441:004. – Byte order is "Big-Endian": 192.168.178.1 ≡ 0x01B2A8C0 (= 28485824)			
-	0x2442:1	Active WLAN settings: Active IP address			
Read only		Display of the active IP address. – If DHCP is activated, the active IP address usually derives from the configured static IP address of the device.			
-	0x2442:2	Active WLAN settings: Active netmask			
Read only		Display of the active netmask.			
-	0x2442:3	Active WLAN settings: Active gateway			
Read only		Display of the active gateway IP address.			
-	0x2448:1	WLAN status: Connection time			
Read only		Display of the connection time in [s] since the current connection was established.			
-	0x2448:2	WLAN status: Number of connections			
Read only		In access point mode: Display of the number of currently connected clients. In client mode: 0 ≡ not connected; 1 ≡ connected with external WLAN network.			
-	0x2448:3	WLAN status: Rx frame counter			
Read only		Display of the number of request received via WLAN.			
-	0x2448:4	WLAN status: Error statistics			
Read only		Display of the quality of the WLAN connection. A display value > 0 indicates communication problems.			

5.9.6 DC BRAKE SETUP

The "DC braking" function generates a braking torque by injecting a DC current into the motor.
The function can be used to shorten the braking of a load with high mass inertia. Another application is holding the motor shaft either before starting or while stopping.

I NOTICE

Avoid long-time activation of the "DC braking" function with a high braking current or a high braking voltage!
Possible consequence: thermal motor overload.

- ▶ Only use the "DC braking" function in applications in which the load is only exceptionally stopped.
- ▶ Do not activate the "DC braking" function longer than necessary

The "DC braking" function is only possible if the VSD is enabled.

The function can be used as follows:

1. Automatically when the motor is started.
 - The start method "DC braking [1]" must be set in P203:1.
 - The DC braking is carried out with the braking current set in P704:1.
 - Only after the hold time P704:2 has elapsed, the motor is accelerated to the setpoint.
2. Automatically when the motor is stopped.
 - In order that the DC braking is automatically active when the motor is stopped, the corresponding operating threshold must be set in P704:3.
 - After a stop command, the motor is first decelerated as set. Only if the output frequency falls below the set operating threshold, the VSD stops the deceleration and activates DC braking.
 - DC braking is carried out with the braking current set in P704:1 for the hold time set in P704:2.
 - The exact behaviour depends on the stop method set in P203:3.
3. Manually (via the flexible I/O configuration).
 - The trigger P400:5 activates the DC braking manually.

The three options can also be combined, for instance automatic DC braking when starting and stopping the motor.

I NOTICE

Motor failure or damage.

During DC-Brake the motor heats up.

- ▶ DC Braking should only be used in applications where the load is stopped infrequently and should only be applied for the minimum time required possible.

P704:1	0x2B84:1	DC braking: Current			
0.0 ... [0.0] ... 200.0 %		Braking current for DC braking. 100 % = rated motor current (P323:0)			
P704:2	0x2B84:2	DC braking: Automatic hold time			
0.0 ... [0.0] ... 1000.0 s		Hold time for automatic DC braking. • The "Automatic DC braking" function is active for the time set here. • 1000.0 = infinite Note! Do not set this parameter to the value "1000.0" (infinite) if the DC braking is used during the start. The "Infinite" setting can be used to lock the rotor for an indefinite time while a stop is active. However, ensure here that the longer DC braking does not cause a thermal overload of the motor!			
P704:3	0x2B84:3	DC braking: Automatic operating threshold			
0.0 ... [0.0] ... 599.0 Hz		Operating threshold for automatic DC braking. With the setting 0, the "Automatic DC braking" function is deactivated.			
P704:4	0x2B84:4	DC braking: Demagnetization time			
0 ... [100] ... 150 % Available from version 4.1		In the default setting, the DC braking is activated after the standard demagnetising time has elapsed. This parameter can be used to adapt the time. 100 % = Default demagnetization time (P704:5) Note! A too short demagnetising time can cause an overcurrent error!			
P704:5	0x2B84:5	DC braking: Default demagnetization time			
Read only: x ms Available from version 4.1		Display of the standard demagnetising time as a setting help for the user. This time is calculated by the VSD: demagnetising time = 7 * rotor time constant			
P704:6	0x2B84:6	DC braking: DC brake with drive disable			
0 ... [0] ... 1		0: standard behaviour. 1: after the automatic DC braking hold time has elapsed, the motor is deenergised (by mean of pulse inhibit) until the setpoint exceeds the automatic DC braking operating threshold.			

5.9.6.1 Example: Automatic DC braking when starting the motor

In order that the DC braking is automatically active when the motor is started, the start method "DC braking [1]" must be set in P203:1.

- The DC braking is carried out with the braking current set in P704:1.
- Only after the hold time P704:2 has elapsed, the motor is accelerated to the setpoint.

Parameter	Name	Setting
P400:1	Enable VSD	Digital input 1 [11]
P400:2	Run	Digital input 2 [12]
P400:4	Reset fault	Not connected [0]
P203:1	Start method	DC braking [1]
P201:1	Frequency control: Default setpoint source	Frequency preset 1 [11]
P450:1	Frequency setpoint presets: Preset 1	40 Hz
P704:1	Current	50%
P704:2	Automatic hold time	10 s

Input signals

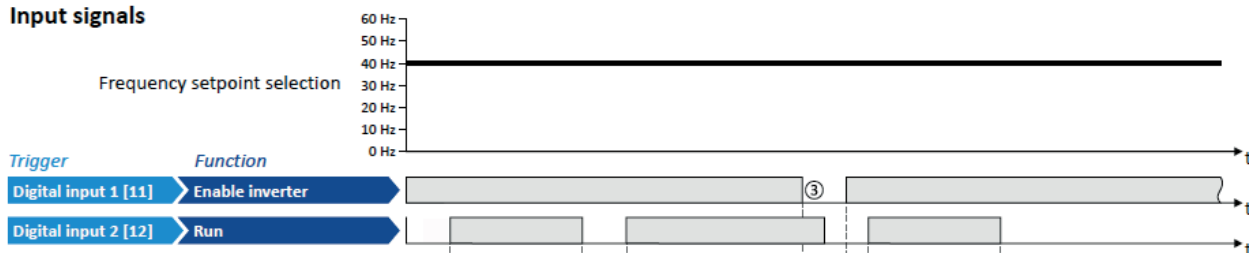

Output signals

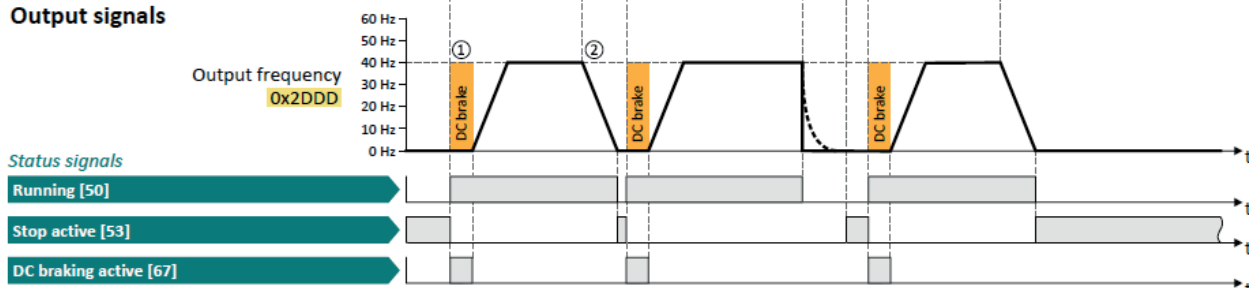

The status signals can be assigned to digital outputs

- ① A mutual locking is required for the contactors Q1 and Q2. After the start command, the DC braking is active. Only after the hold time P704:2 has elapsed, the motor is accelerated to the setpoint.
- ② The motor is stopped with the stop method set in P203:3. In the example: Stop with standard ramp.
- ③ If the VSD is disabled, the motor coasts.

5.9.6.2 Example: Automatic DC braking when stopping the motor

In order that the DC braking is automatically active when the motor is stopped, the corresponding operating threshold must be set in P704:3.

- After a stop command, the motor is first decelerated as set. Only if the output frequency falls below the set operating threshold, the VSD stops the deceleration and activates DC braking.
- DC braking is carried out with the braking current set in P704:1 for the hold time set in P704:2.
- The exact behaviour depends on the stop method set in P203:3.

Stop method = "Standard ramp [1]"

Parameter	Name	Setting
P400:1	Enable VSD	Digital input 1 [11]
P400:2	Run	Digital input 2 [12]
P400:4	Reset fault	Not connected [0]
P203:3	Stop method	Standard ramp [1]
P201:1	Frequency control: Default setpoint source	Frequency preset 1 [11]
P450:1	Frequency setpoint presets: Preset 1	40 Hz
P704:1	Current	50%
P704:2	Automatic hold time	10 s
P704:3	Automatic operating threshold	15 Hz

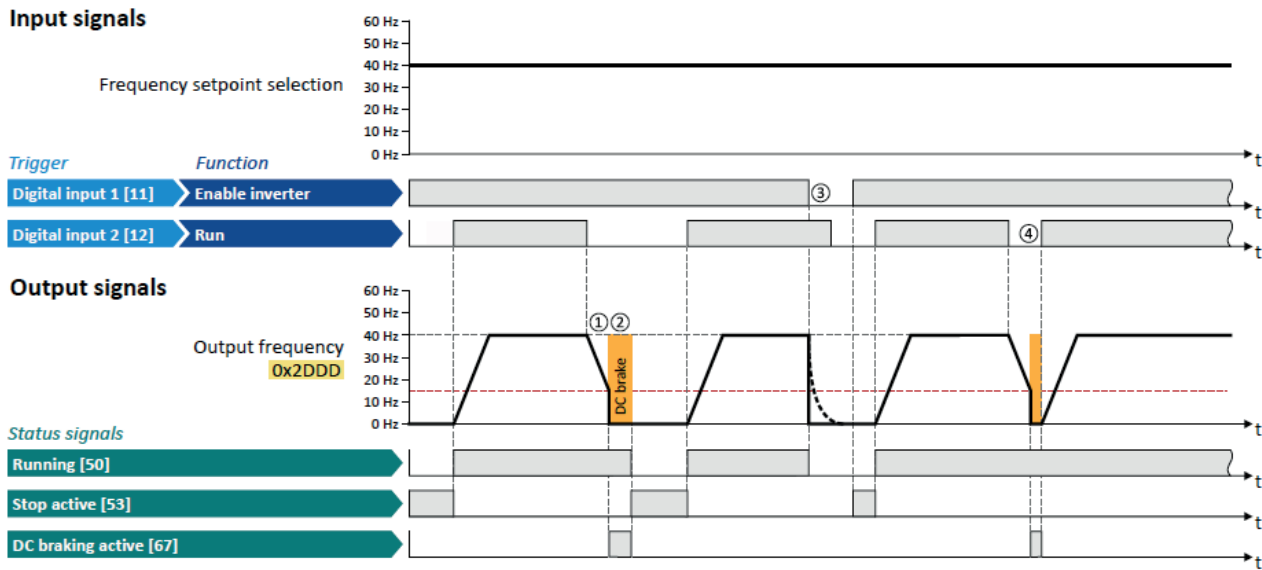

The status signals can be assigned to digital outputs.

- ① With the stop method "Standard ramp [1]", the motor is first decelerated normally until the value falls below the operating threshold set in P704:3.
- ② The DC braking becomes active for the hold time set in P704:2.
- ③ If the VSD is disabled, the motor coasts. (DC braking is only possible if the VSD is enabled.)
- ④ If there is a new start command within the hold time, the DC braking is cancelled. The motor is accelerated to the setpoint again.

Stop method = "Quick stop ramp [2]"

Same behaviour as with the stop method "Standard ramp [1]", except that the motor is decelerated with the quick stop ramp instead of the standard ramp.

Stop method = "Coasting [0]"

Parameter	Name	Setting
P400:1	Enable VSD	Digital input 1 [11]
P400:2	Run	Digital input 2 [12]
P400:4	Reset fault	Not connected [0]
P203:3	Stop method	Coasting [0]
P201:1	Frequency control: Default setpoint source	Frequency preset 1 [11]
P450:1	Frequency setpoint presets: Preset 1	40 Hz
P704:1	Current	50%
P704:2	Automatic hold time	10 s
P704:3	Automatic operating threshold	15 Hz

Input signals

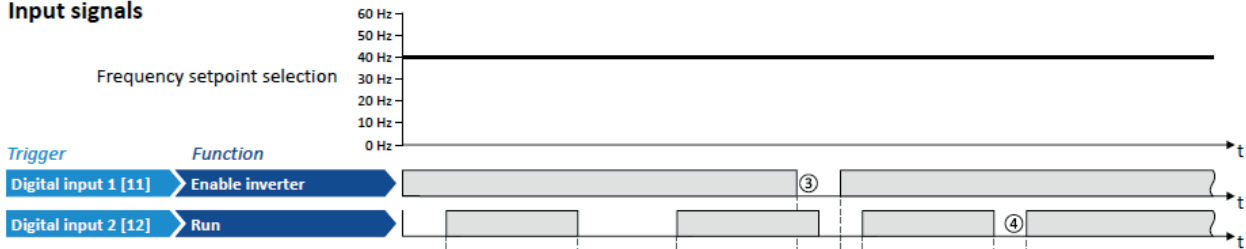

Output signals

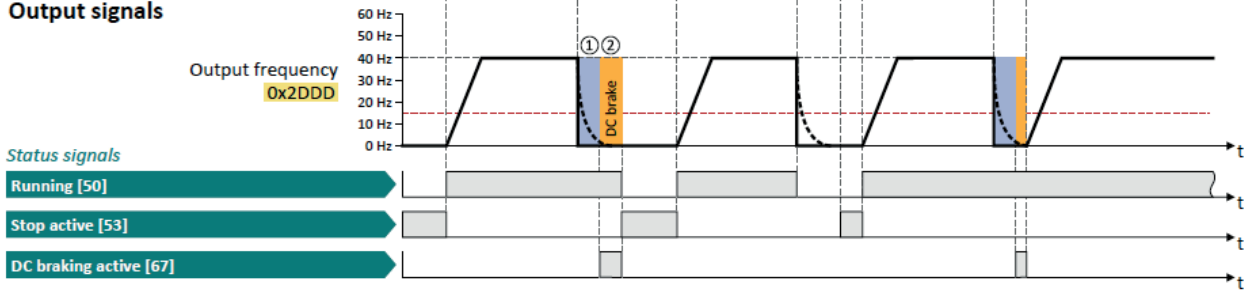

The status signals can be assigned to digital outputs.

- ① With the stop method "Coasting [0]", the motor first coasts down for a specified time. This "demagnetising time" serves to reduce the induced voltage.
- ② The DC braking becomes active for the hold time set in P704:2.
- ③ If the VSD is disabled, the motor coasts. (DC braking is only possible if the VSD is enabled).
- ④ If there is a new start command within the hold time, the DC braking is cancelled. The motor is accelerated to the setpoint again.

5.9.6.3 Activating DC braking manually
By means of the 'Activate DC braking' function, DC braking can be activated manually.

Preconditions
The current for DC braking must be set > 0 % so that the function can be executed.

P400:5	0x2631:5	Activate DC braking			
0: Not connected (Reference see P400:1)		Trigger = TRUE: Activate DC braking. Trigger = FALSE: Deactivate DC braking. CAUTION! DC braking remains active as long as the trigger is set to TRUE.			

Example for operating mode
- Switch S1 starts the motor in forward direction of rotation. Switch S1 in the initial position stops the motor again.
- Switch S2 activates DC braking.

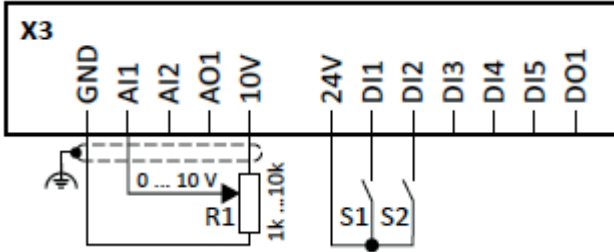

R1 = Frequency setpoint selection
S1 = Run
S2 = Activate DC braking

Parameter	Name	Setting
P400:1	Enable VSD	Constant TRUE [1]
P400:2	Run	Digital input 1 [11]
P400:4	Reset fault	Not connected [0]
P400:5	Activate DC braking	Digital input 2 [12]
P200:0	Control selection	Flexible I/O configuration [0]
P203:3	Stop method	Standard ramp [1]
P201:1	Frequency control: Default setpoint source	Analog input 1 [2]
P704:1	Current	10%

Input signals

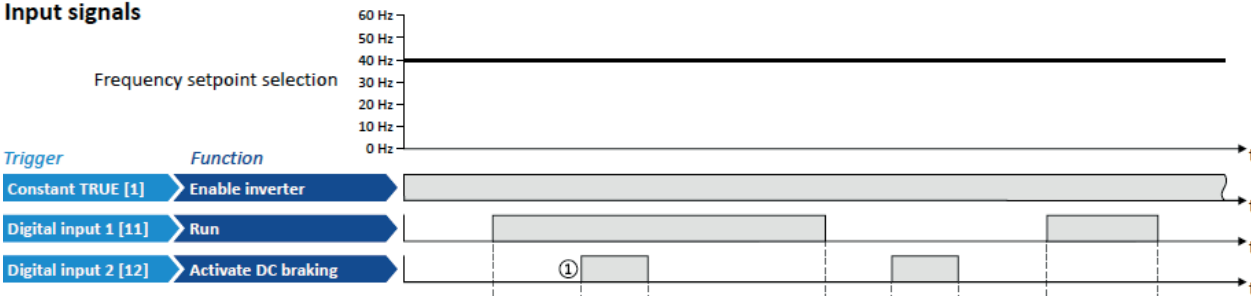

Output signals

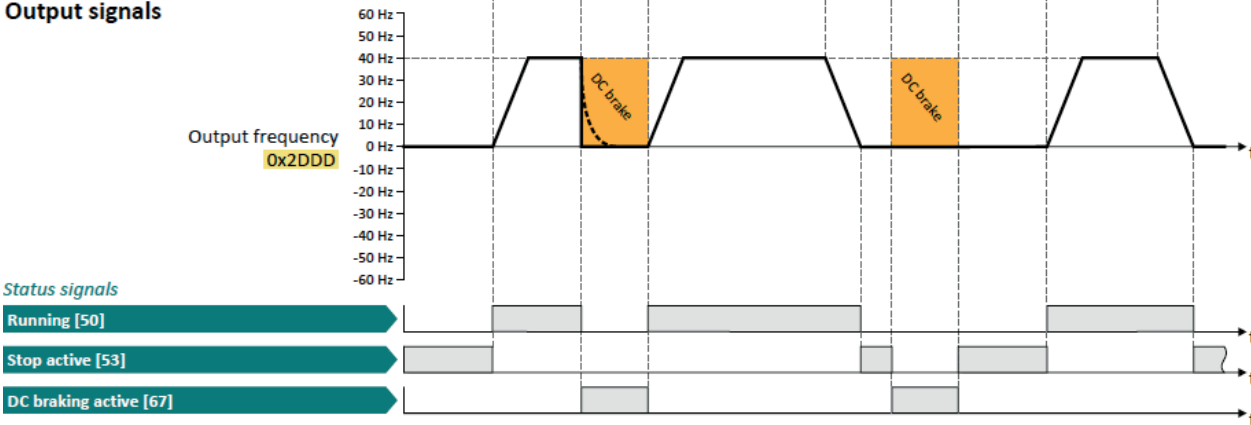

The status signals can be assigned to digital outputs.

- ① If DC braking is activated while the motor is running, the output pulses of the VSD are disabled immediately. For stopping the motor, the current set in P704:1 is injected. The exact drive behaviour depends on the settings for the "DC braking" function and the load properties.

5.9.7 BRAKE ENERGY MANAGEMENT

When braking electrical motors, the kinetic energy of the drive train is fed back regeneratively to the DC bus. This energy causes a DC-bus voltage boost. If the energy fed back is too high, the VSD reports an error.

Several different strategies can serve to avoid DC-bus overvoltage:

- Use of a brake resistor
- Stopping the deceleration ramp function generator when the active voltage threshold for the brake operation is exceeded
- Use of the "VSD motor brake" function
- Combination of the above named options
- DC-bus connection

Details

The voltage threshold for braking operation results on the basis of the rated mains voltage set.

Rated mains voltage	Voltage thresholds for braking operation	
	Braking operation on	Braking operation off
230V	DC 390V	DC 380V
400V	DC 725V	DC 710V
480V	DC 780V	DC 765V

The voltage threshold for braking operation can be reduced by 0 ... 100 V. The reduction required must be set in P706:3. However, the reduction must be made to such an extent that the reduced voltage threshold is still above the normal stationary DC-bus voltage.

The active voltage threshold for the braking operation is displayed in P706:2.

If the DC-bus voltage exceeds the voltage threshold for braking operation, the braking method selected in P706:1 is applied.

- Optimum following of the actual frequency value to the frequency setpoint (e. g. quick stop of the motor) can always be achieved by the use of a brake resistor.
- Stopping the deceleration ramp function generator enables smoother deceleration with lower torque oscillation.
- The "VSD motor brake" function allows for quick braking without using a brake resistor.

For process-related reasons, torque oscillations may occur.

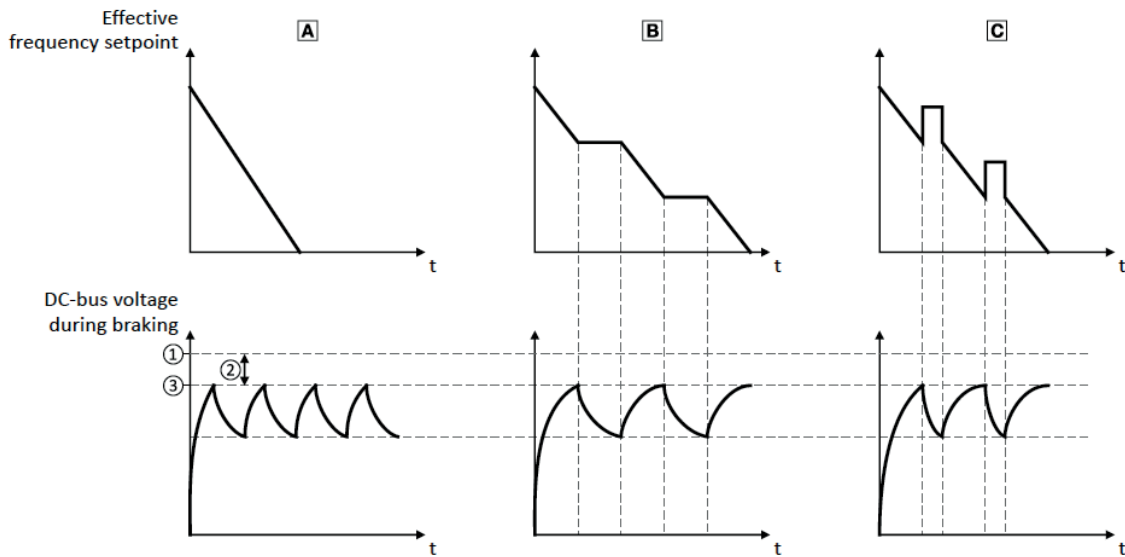

- ① Voltage threshold for braking operation
- ② Reduced threshold P706:3
- ③ Active threshold P706:2

- [A] Use of a brake resistor
- [B] Stopping the deceleration ramp function generator
- [C] VSD motor brake

P706:1	0x2541:1	Brake energy management: Operating mode			
0: Brake resistor 1: Ramp function generator stop (RFGS) 2: Brake resistor + RFGS 3: VSD motor brake (IMB) + RFGS 4: Brake resistor + IMB + RFGS		Selection of the braking method. The braking method(s) selected is/are activated if the DC-bus voltage exceeds the voltage threshold for the braking operation shown in P706:2. 0: Brake resistor The integrated brake chopper (brake transistor) is used. 1: Ramp function generator stop (RFGS) The deceleration ramp function generator is stopped. 2: Brake resistor + RFGS The brake resistor is supplied with current and the deceleration ramp function generator is stopped. 3: VSD motor brake (IMB) + RFGS Braking with the "VSD motor brake" braking method in connection with "Deceleration ramp function generator stop" is executed. 4: Brake resistor + IMB + RFGS Braking is performed by combining all three braking procedures.			
P706:2	0x2541:2	Brake energy management: Active threshold			
Read only: x V		Display of the active voltage threshold for the braking operation. – The voltage threshold shown depends on the mains voltage selected in P208:1 and the voltage value set in P706:3. – The voltage threshold must be higher than the stationary DC voltage in the DC bus.			
P706:3	0x2541:3	Brake energy management: Reduced threshold			
0 ... [0] ... 100 V		The voltage threshold for the braking operation is reduced by the voltage value set here.			
P706:5	0x2541:5	Brake energy management: Deceleration override time			
0.0 ... [2.0] ... 60.0 s		Maximum permissible time for the deceleration override by means of the braking method selected in P706:1. – If the DC-bus voltage does not fall below the voltage threshold for braking operation shown in P706:2 within this time, the motor is decelerated further. – The time is only reset if the voltage threshold shown in P706:2 is not reached.			

5.9.7.1 Use of a brake resistor

For braking operation, optionally the brake chopper integrated in the VSD (brake transistor) can be used.

i NOTICE

Incorrect dimensioning of the brake resistor may result in the destruction of the integrated brake chopper (brake transistor).

- ▶ Only connect a brake resistor complying in terms of performance to terminals R_{B1} and R_{B2} of the VSD.
- ▶ Avoiding thermal overload of the brake resistor.

Preconditions

In order that the integrated brake chopper is activated in the braking operation, one of the following braking methods must be set in P706:1:

- "Brake resistor [0]"
- "Brake resistor + RFGS [2]"
- "Brake resistor + IMB + RFGS [4]"

In the default setting of P706:1, the integrated brake chopper is not activated in the brake operation!

Details

- The brake resistor required is to be connected to terminals R_{B1} and R_{B2} of the VSD.
 - In P706:1, additionally the stopping function for the deceleration ramp function generator can be set when the brake resistor is controlled, in order to avoid overvoltage disconnection in the case of lower deceleration times.
 - In the default setting and with a disabled VSD and an error status ("Error active"), the brake chopper is switched off. This behaviour can be changed in P706:6.
- Example: In a DC-bus connection with several VSDs, only one brake resistor is used. It is connected to the most powerful VSD in the DC-bus connection. This VSD then serves to change the behaviour so that VSD disable and/or an error does not cause a switch-off of the brake chopper.

Internal protective function

The following protective function prevents the brake chopper from being switched on permanently, e.g. due to too high voltages or wrong settings:

- The brake chopper is switched off if it was switched on over a period of 4 s.
- If the DC-bus voltage again falls below the voltage threshold for braking operation, the brake chopper can again be switched on for maximally 4 s without interruption.

Brake resistor monitoring

The VSD calculates and monitors the thermal load of the brake resistor to ensure that the brake resistor will not be overloaded.

A correct calculation required the following settings according to the data on the nameplate of the brake resistor:

- P707:2: Resistance value
- P707:3: Rated power
- P707:4: Maximum thermal load

The calculated thermal load is not displayed in P707:7.

The brake resistor monitoring is designed with two stages:

- If the calculated thermal load exceeds the warning threshold set in P707:8 (default setting: 90 %), the response set in P707:10 takes place (default setting: "Warning"). The warning status will be reset if the thermal load falls below the warning threshold - 20 %.
- If the calculated thermal load exceeds the warning threshold set in P707:9 (default setting: 100 %), the response set in (P707:11) takes place (default setting: "Fault"). The error status will be reset if the thermal load falls below the error threshold - 20 %.

P706:6	0x2541:6	Brake energy management: Brake resistor response			
0: Off: disable and error 1: On: disable / off: error 2: Off: disable / on: error 3: On: disable and error		Behaviour of the integrated brake chopper if the VSD is disabled and if the error status is active. 0: Off: disable and error If the VSD is disabled and the error status is active, the brake chopper is switched off. 1: On: disable / off: error Brake chopper is switched off if the error status is active, but not if the VSD is disabled. 2: Off: disable / on: error Brake chopper is switched off if the VSD is disabled but not if the error status is active. 3: On: disable and error Brake chopper is not switched off if the VSD disabled and the error status is active.			
P707:2	0x2550:2	Brake resistor: Resistance value			
0.0 ... [Type Code dependent] ... 500.0 Ω		Resistance value of the brake resistor connected. The value to be entered can be obtained from the brake resistor nameplate.			
P707:3	0x2550:3	Brake resistor: Rated power			
0 ... [Type Code dependent] ... 800000 W		Rated power of the brake resistor connected. The value to be entered can be obtained from the brake resistor nameplate.			
P707:4	0x2550:4	Brake resistor: Maximum thermal load			
0.0 ... [Type Code dependent] ... 100000.0 kW		Thermal capacity of the brake resistor connected. The value to be entered can be obtained from the brake resistor nameplate.			
P707:7	0x2550:7	Brake resistor: Thermal load			
Read only: x.x %		Display of the utilisation of the brake resistor connected.			
P707:8	0x2550:8	Brake resistor: Warning threshold			
50.0 ... [90.0] ... 150.0 %		Warning threshold for brake resistor monitoring. – If the utilisation shown in P706:4 reaches the threshold set, the response selected in P707:10 is effected. – The warning is reset with a hysteresis of 20 %.			
P707:9	0x2550:9	Brake resistor: Error threshold			
50.0 ... [100.0] ... 150.0 %		Error threshold for brake resistor monitoring. – If the utilisation shown in P706:4 reaches the threshold set, the response selected in P707:11 is effected. – Resetting the error is only possible if the hysteresis is lower than 20 %.			
P707:10	0x2550:10	Brake resistor: Response to warning			
1: Warning (Reference see P310:1)		Selection of the response that is executed when the warning threshold for brake resistor monitoring is reached. Associated error code: 65334 0xFF36 - Brake resistor: overload warning			
P707:11	0x2550:11	Brake resistor: Response to error			
3: Fault (Reference see P310:1)		Selection of the response to be executed when the error threshold for brake resistor monitoring is reached. Associated error code: 65282 0xFF02 - Brake resistor: overload fault			

5.9.7.2 Stopping the deceleration ramp function generator

The deceleration ramp function generator is stopped for a short time if the voltage threshold for braking operation is exceeded.

When this braking method is selected, the maximum permissible time for the deceleration override has to be set in P706:5.

- If the DC-bus voltage does not fall below the voltage threshold for braking operation shown in P706:2 within this time, the motor is decelerated further.
- The time is only reset if the voltage threshold shown in P706:2 is not reached.

5.9.7.3 VSD motor brake

With this braking method, which can be selected in P706:1, the regenerative energy in the motor is converted as a result of dynamic acceleration/deceleration with downramping of the ramp function generator.

i NOTICE

Too frequent braking may cause thermal overload of the motor.

- Avoid activating the "VSD motor brake" function over a longer time!
- In applications with a high mass inertia and long braking times (> 2 s), use the "DC braking" function.

Preconditions

- The "VSD motor brake" braking method must not be used with vertical conveyors (hoists) or with active loads!
- The "VSD motor brake" braking method only works in operating mode P301:0 = "MS: Velocity mode [-2]".
- When this braking method is used, the motor overload monitoring is not adapted. A too frequent use of the VSD motor brake may cause an incorrect operation of the motor overload monitoring.

Details

During the deceleration process, the ramp function generator is stopped. The frequency set in P706:4 is added to the frequency setpoint, taking the sign of the current actual frequency into consideration. Furthermore the ramp function generator is stopped in a state of overvoltage. If the DC-bus voltage falls below a defined DC-bus voltage potential, the additional frequency connected is reduced again and the ramp function generator is re-activated.

By the alternating acceleration and deceleration resulting from this circuit, the energy is converted thermally in the motor. For process-related reasons, torque oscillations may occur.

Setting instructions

Generally, the smallest value possible required by the application for being able to still traverse the load to be moved in a controlled fashion should be set as additional frequency. Greater mass inertia values require an increase in the rated motor frequency set. Increasing the rated motor frequency, however, causes greater torque oscillations. A possible consequence is the reduced service life of mechanical components. Furthermore an increase in the rated motor frequency also increases the energy converted into heat in the motor. A possible consequence is the reduced service life of the motor.

P706:4	0x2541:4	Brake energy management: Additional frequency			
0.0 ... [0.0] ... 10.0 Hz		Frequency deviation which is connected to the deceleration ramp in a pulsative fashion when the "VSD motor brake" braking method is used.			

5.9.8 LOAD LOSS DETECTION

This function serves to detect a load loss during operation and to then activate a specific function, for instance the switching of the relay.

If, during operation, the current motor current falls below the threshold set in P710:1 for at least the time set in P710:2, the internal status signal "Load loss detected [83]" is set to TRUE:

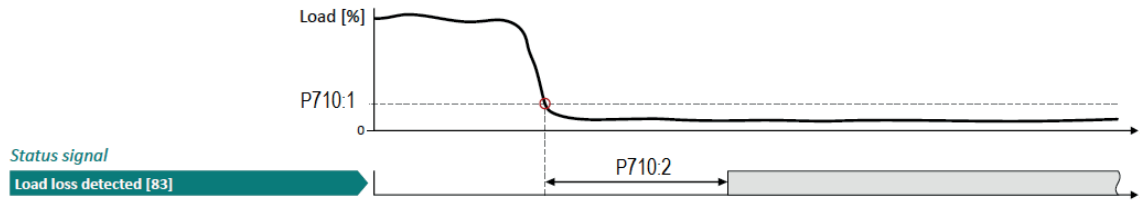

- The threshold is set in percent with reference to the rated motor current "Motor rated current" (P323:0).
- The status signal "Load loss detected [83]" can be assigned, for instance, to a digital output or the relay via the flexible I/O configuration.
- The load loss detection is not active with active DC braking.

P710:1	0x4006:1	Load loss detection: Threshold			
0.0 ... [0.0] ... 200.0%		Threshold for load loss detection. 100 % ≙ rated motor current (P323:0)			
P710:2	0x4006:2	Load loss detection: Deceleration			
0.0 ... [0.0] ... 300.0 s		Tripping delay for load loss detection.			

5.9.9 HOLDING BRAKE CONTROL

This function serves as a low-wear control of a holding brake. The holding is usually mounted to the motor as an option. The holding brake can be automatically released via the start command for the VSD or manually via an external control signal, for instance, by a higher-level Controller. The interaction of higher-level Controller and holding brake is especially important for vertical applications. Horizontal applications need a less demanding holding brake control.

Preconditions

- Observe that the holding brake is an important element of the machine's safety concept as a whole. Therefore be sure to carry out commissioning of this system part with particular care!
- Holding brakes are not intended for braking during operation. The increased wear caused by braking during operation may destroy the holding brake prematurely!
- The holding brake control itself only outputs a digital trigger for releasing the holding brake. This trigger "Release holding brake [115]" must be assigned to a digital output or, in the simplest case, to the relay when then switches the brake supply.
- If the holding brake is to be controlled via a digital output, the use of an additional relay or power contactor is required. The digital output is not suited for direct control of a holding brake.
- If, instead of an electrically releasing (self-holding) holding brake, an electrically holding (self-releasing) holding brake is to be controlled, a signal inversion for the digital output used or for the relay is to be set!

See parameter P420:1 (Digital outputs function: Relay).

5.9.9.1 Holding brake control: basic setting

The following parameters must be set for the activation and basic setting of the holding brake control.

- i** When a power contactor is used, the response time and release time of the contactor are added to the brake application and release time. Both times must also be taken into consideration for parameterising the brake application time and brake opening time!

P712:1	0x2820:1	Holding brake control: Brake mode			
0: Automatically (via device state) 1: Manually 2: Off		Selecting how the "Release holding brake" command is to be triggered. 0: Automatically (via device state) The "Release holding brake" command is automatically carried out as a function of the device state and further conditions. CAUTION! Also in the automatic operation, a manual release of the holding brake is possible! For details see the following information for selection "Manually [1]". 1: Manually The "Release holding brake" command can also be initiated by the following external triggers: – Via the trigger assigned to the "Release holding brake" function in P400:49 if the network control is not active. – Via bit 14 in the CiA 402 control word 0x6040 if the network control is active. CAUTION! – The manually triggered "Release holding brake" command has a direct impact on the "Release holding brake [115]" trigger. Thus, the holding brake can be manually released if the power section is switched off! – The responsibility for a manual release of the holding brake has the external trigger source for the "Release holding brake" command! 2: Off The holding brake is deactivated.			
P712:2	0x2820:2	Holding brake control: Brake closing time			
0 ... [100] ... 10000 ms		Application time (engagement time) of the holding brake. – Only effective in automatic operation.			
P712:3	0x2820:3	Holding brake control: Brake opening time			
0 ... [100] ... 10000 ms		Release time (disengagement time) of the holding brake. – Only effective in automatic operation.			
P712:15	0x2820:15	Holding brake control: Brake status			
Read only 0: Active 1: Brake released		Display of the holding brake status.			

5.9.9.2 "Automatic" brake mode (automatic operation)

In automatic operation, the VSD automatically released the holding brake when the motor is started. In the stopped state, the holding brake is closed.

DANGER!
Manual release of the holding brake
Also in automatic operation, a manual release of the holding brake is possible. The manually triggered "Release holding brake" command has a direct impact on the "Release holding brake [115]" trigger. Thus, the holding brake can be manually released if the power section is switched off.
► The responsibility for a manual release of the holding brake has the external trigger source for the "Release holding brake" command!

Preconditions
Automatic operation is only available if the operating mode "MS: Velocity mode [-2]" or "MS: Torque mode [-1]" is set in P301:0.

General mode of operation
The following diagram demonstrates the general functioning of the automatic operation:

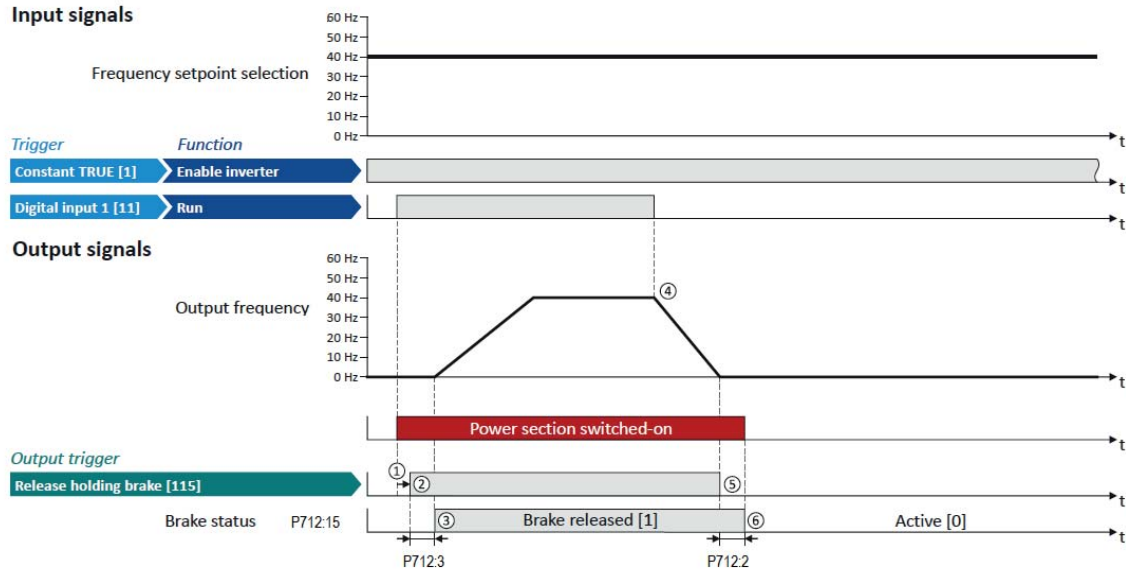

- ① If the VSD is enabled and no error is active, the motor can be started with the "Run" function in forward rotating direction. The power section is switched on and the motor is magnetised first.
- ② The holding brake is released. For this purpose, the output trigger "Release holding brake [115]" is set to TRUE. This trigger must be assigned to a digital output or, in the simplest case, to the relay which then switches the brake supply.
- ③ After the release time P712:3 has elapsed, the motor is accelerated to the setpoint. The brake status "Brake released [1]" is displayed in P712:15.
- ④ If "Run" is set to FALSE, the motor is stopped with the stop method set in P203:3. In the example: Stop with standard ramp.
- ⑤ Then the holding brake is closed again.
- ⑥ After the closing time P712:2 has elapsed, the brake status "Active [0]" is displayed in P712:15.

i If the power section is disabled, the holding brake is closed. Reasons for this can be an error, a fault, or the activation of the "Safe torque off (STO)" safety function.

5.9.9.3 Brake holding load

Depending on the application, a torque at the motor may be required at speed "0" of the motor shaft:

- In order to hold loads in vertical applications and prevent "sagging".
- In order to prevent a position loss in horizontal applications.

For this purpose, a brake holding load can be set. The brake holding load can be optionally generated via a ramp to reduce a vibration stimulation that may be caused by the brake holding load.

Preconditions

Ensure that the VSD builds up a sufficient torque in the motor when releasing and applying the holding, in order to hold the load.

- For this purpose, a V/f voltage boost can be set for the V/f characteristic control.
- The parameters for the V/f voltage boost are automatically set when you carry out an automatic identification of the motor.

Details

Relevant parameters:

- P712:8: Brake holding load
- P712:13: Holding load ramptime

Setting notes:

- In case of applications with constant load, a constant value is suitable for the brake holding load.
- If the load constantly changes, an approximate value for the brake holding load has to be considered.
- Start with the setting "0 %" if you do not know the correct direction, otherwise with, for instance, "30 %". Afterwards change the setting upwards or downwards in 10-% steps.

P712:8	0x2820:8	Holding brake control: Brake holding load			
-500.0 ... [0.0] ... 500.0 %		By setting a holding load, the load can be held against the force of gravity in case of vertical applications, and a position loss can be prevented in case of horizontal applications. - The setting of "100 %" approximately corresponds to rated motor torque and slip frequency. Note! The torque for creating the holding load depends on the selected motor control type and its settings. Before using this function, make sure that you have set the motor control type correctly.			
P712:13	0x2820:13	Holding brake control: Holding load ramptime			
0 ... [0] ... 100 ms Available from version 4.1		By setting a ramp time, a vibration stimulation can be reduced that might be caused by the brake holding load P712:8.			

The following diagram demonstrates the general functioning in automatic operation:

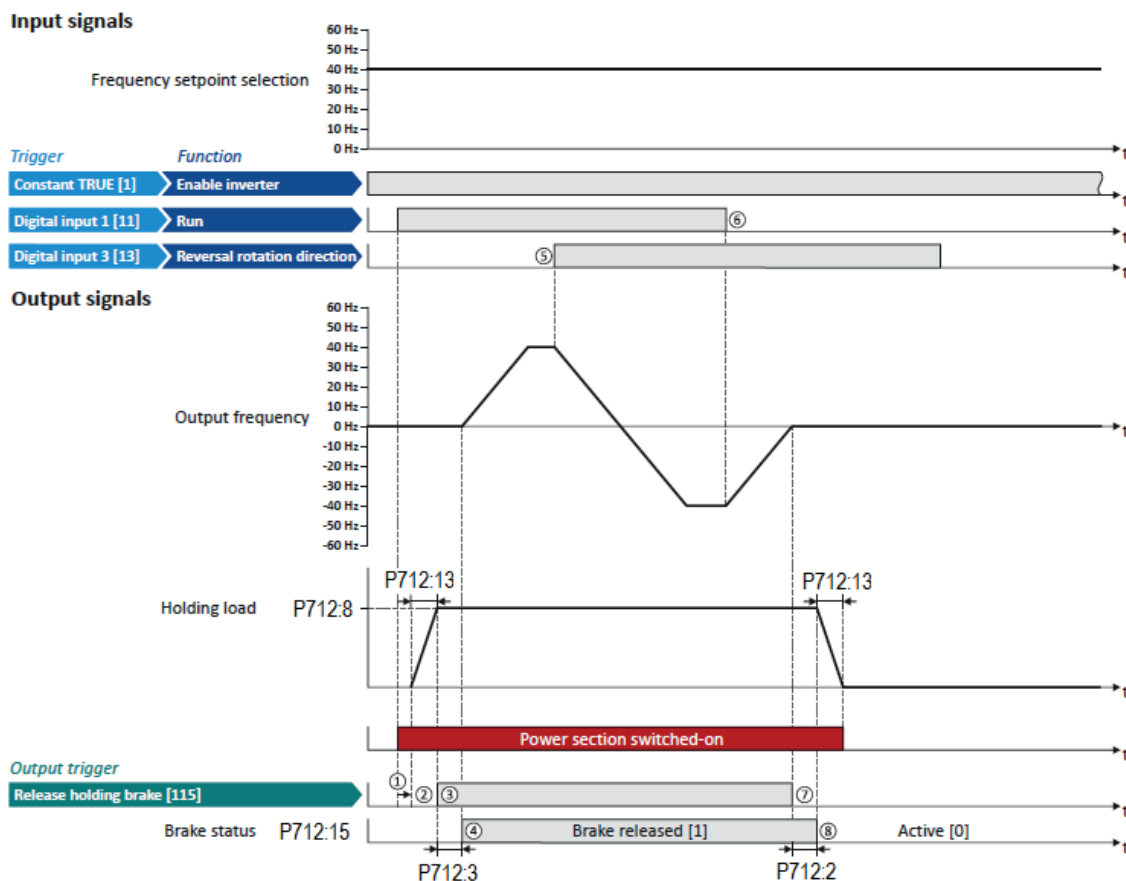

- ① If the VSD is enabled and no error is active, the motor can be started with the "Run" function in forward rotating direction. The power section is switched on and the motor is magnetised first.
- ② The brake holding load set in P712:8 is build up via the ramp set in P712:13.
- ③ The holding brake is released. For this purpose, the output trigger "Release holding brake [115]" is set to TRUE. This trigger must be assigned to a digital output or, in the simplest case, to the relay which then switches the brake supply.
- ④ After the release time P712:3 has elapsed, the motor is accelerated to the setpoint. The brake status "Brake released [1]" is displayed in P712:15.
- ⑤ In case the direction of rotation reverses, the holding brake remains released.
- ⑥ If "Run" is set to FALSE, the motor is stopped with the stop method set in P203:3. In the example: Stop with standard ramp.
- ⑦ Then the holding brake is closed again.
- ⑧ After the closing time P712:2 has elapsed, the brake status "Active [0]" is displayed in P712:15. The brake holding load is reduced again via the ramp

5.9.9.4 Brake closing level

In some cases, a low speed does not make any sense from the application point of view. This includes applications with unfavorable load features, such as static friction. In such applications and depending on the type of control, a low speed may cause an unwanted behaviour. In order to prevent such an operating situation, a closing threshold can be set. The power section will only be switched on and the holding brake is opened if the setpoint is higher than the closing threshold. In order to prevent the holding brake from being closed if the setpoint only shortly falls below the closing threshold during operation, a delay time can be set in addition.

Preconditions

If the holding brake is controlled manually via an external control signal: It must be ensured that the motor does not move while the motor control is deactivated by this function.

Details

The function is part of the holding brake control and does not have an independent functionality.

Relevant parameters:

- P712:7: Brake closing threshold
- P712:12: Closing threshold delay

Setting notes:

- The function is active if the brake closing threshold is higher than 0 Hz.
- In order that the brake can work correctly, the brake closing threshold must be set to a value that is greater than or equals the minimum frequency P210:0.
- The brake closing threshold has a permanent hysteresis of 1 Hz in order to prevent an unwanted change-over. Exception: If the brake closing threshold is set to 0 Hz, the hysteresis is also 0 Hz.
- If the brake closing threshold is set to 0 Hz, a start command is only required to release the holding brake during automatic operation.
- This function can be combined with the setting of a holding load.

P712:7	0x2820:7	Holding brake control: Brake closing threshold
0.0 ... [0.2] ... 599.0 Hz		Threshold for closing the holding brake. <ul style="list-style-type: none"> - The power section will only be switched on and the holding brake will be opened if the setpoint is higher than the threshold set here. - In order that the brake can work correctly, the brake closing threshold must be set to a value that is greater than or equals the minimum frequency P210:0. - The brake closing threshold has a permanent hysteresis of 1 Hz in order to prevent an unwanted change-over. Exception: If the brake closing threshold is set to 0 Hz, the hysteresis is also 0 Hz. - In case of a setting of "0 Hz", only a start command is required to release the holding break during automatic operation.
P712:12	0x2820:12	Holding brake control: Closing threshold delay
0 ... [0] ... 10000 ms Available from version 4.1		By setting a deceleration, a closing of the holding brake can be prevented if the frequency only temporarily falls below the brake closing threshold (P712:7).

The following diagram demonstrates the general functioning in automatic operation:

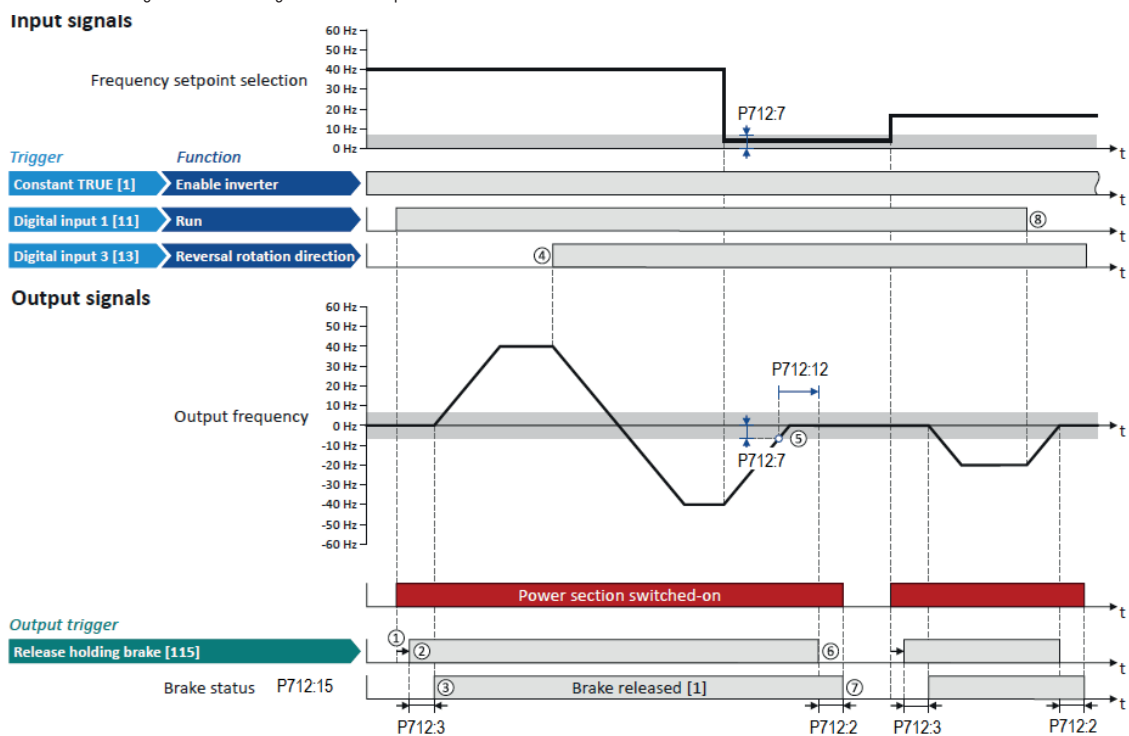

- ① If the VSD is enabled and no error is active, the motor can be started with the "Run" function in forward rotating direction. The power section is switched on and the motor is magnetised first.
- ② The holding brake is released. For this purpose, the output trigger "Release holding brake [115]" is set to TRUE. This trigger must be assigned to a digital output or, in the simplest case, to the relay which then switches the brake supply.
- ③ After the release time P712:3 has elapsed, the motor is accelerated to the setpoint. The brake status "Brake released [1]" is displayed in P712:15.
- ④ If the direction of rotation reverses, the holding brake remains released (even if the closing threshold delay is running.)
- ⑤ If the setpoint selection and the internal setpoint for the motor control fall below the brake closing threshold set in P712:7, the output frequency is ramped down to "0 Hz". At the same time the closing threshold delay set in P712:12 starts to run.
- ⑥ If the values fall below the closing threshold longer than the closing threshold delay, the holding brake is closed again.
- ⑦ After the closing time P712:2 has elapsed, the brake status "Active [0]" is displayed in P712:15.
- ⑧ If "Run" is set to FALSE, the motor is stopped with the stop method set in P203:3. In the example: Stop with standard ramp. In this case, closing threshold and closing threshold delay are not effective anymore.

5.9.9.5 Manual release of the holding brake

A manual release of the holding brake is possible in the modes "Automatic [0]" and "Manual [1]" via the following external triggers:

- Via bit 14 in the CiA 402 Controlword 0x6040.
- Via the trigger assigned in P400:49 of the "Release holding brake" function.

P400:49	0x2631:49	Function list: Release holding brake			
0: Not connected (Reference see P400:1)		Assignment of a trigger for the "Release holding brake" function. Trigger = TRUE: Release holding brake (immediately). Trigger = FALSE: no action. Notes: - Function is only executed if the brake mode P712:1 is set to "Automatic [0]" or "Manual [1]". CAUTION! - The manually triggered "Release holding brake" command has a direct impact on the "Release holding brake [115]" trigger. Thus, the holding brake can be manually released if the power section is switched off! - The responsibility for a manual release of the holding brake has the external trigger source for the "Release holding brake" command!			

Example for operating mode

- Switch S1 starts the motor in forward direction of rotation. Switch S1 in the initial position stops the motor again.
- Switch S2 opens the holding brake. For this purpose, in this example, trigger "Release holding brake [115]" is assigned to the relay that switches the brake supply.

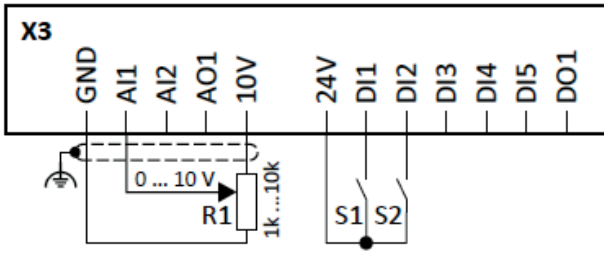

R1 = Frequency setpoint selection
 S1 = Run
 S2 = Open holding brake

Parameter	Name	Setting
P400:1	Enable VSD	Constant TRUE [1]
P400:2	Run	Digital input 1 [11]
P400:4	Reset fault	Not connected [0]
P400:49	Open holding brake	Digital input 2 [12]
P420:1	Relay output function	Release holding brake [115]
P200:0	Control selection	Flexible I/O configuration [0]
P203:3	Stop method	Standard ramp [1]
P201:1	Frequency control: Default setpoint source	Analog input 1 [2]

Input signals

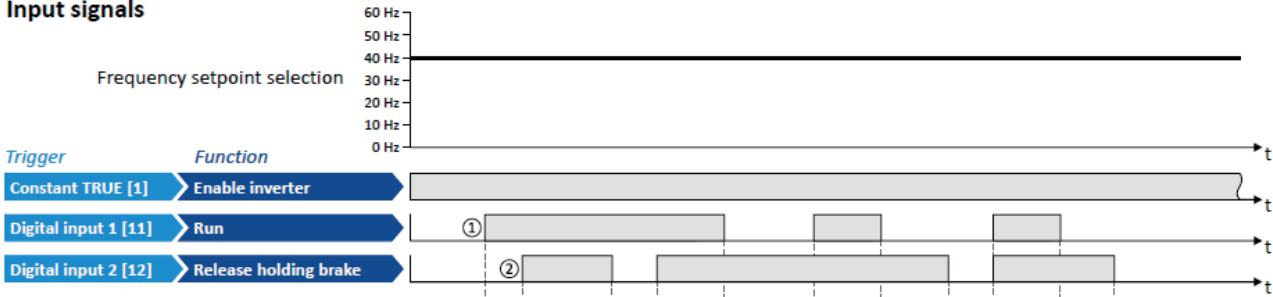

Output signals

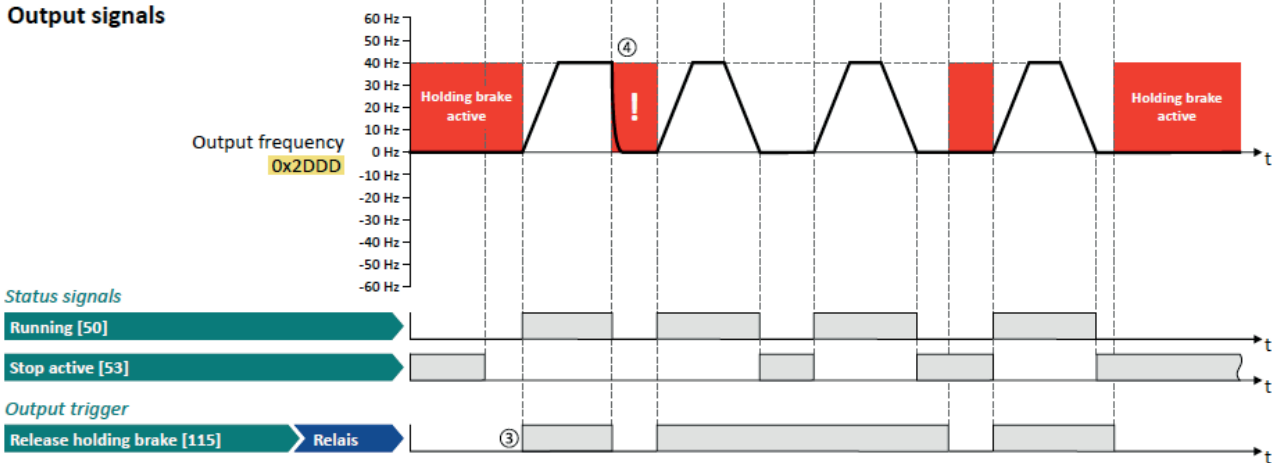

The status signals can be assigned to digital outputs.

- ① As the holding brake is active, the motor does not yet start to rotate after the start command.
- ② The holding brake is opened. The motor is led to the setpoint.
- ③ In this example, the "Release holding brake [115]" trigger is assigned to the relay that switches the brake supply. In the idle state, the holding brake is applied. If the relay is energised, the holding brake is opened.
- ④ Note: Holding brakes are not intended for braking during operation. The increased wear caused by braking during operation may destroy the holding brakes prematurely!

5.9.10 FLYING RESTART CIRCUIT

The flying restart function makes it possible to restart a coasting motor on the fly during operation without speed feedback. Synchronicity between the VSD and the motor is coordinated so that the transition to the rotating drive is effected without jerk at the time of connection.

i The following description and the listed parameters are valid for the flying restart circuit of an asynchronous motor. For information on a flying restart circuit in case of a sensorless control of a synchronous motor, see chapter "5.5.2.5 Sensorless control for synchronous motors (SLPSM)".

Preconditions

- Drive systems with speed feedback do not need a flying restart circuit because there is always a jerk-free synchronisation to the feedback speed.
- The flying restart circuit operates safely and reliably in case of drives with high centrifugal masses. If several motors with different centrifugal masses are connected to the VSD, the flying restart circuit must not be used.
- The flying restart circuit serves to identify rotating field frequencies of up to maximally ± 200 Hz.
- Especially at high power, very high mass inertias and mains voltages higher than 440 V, a temporary overvoltage in the DC bus may occur. The use of a brake resistor can prevent this behaviour.

Required settings before the flying restart circuit is used:

1. The motor data must be set correctly.
2. The settings for the current controller and the flying restart controller must be adapted to the motor. The settings are made automatically if one of the following optimisations is carried out: Automatic motor identification (energized) or Automatic motor calibration (non-energized).

Details

The VSD determines synchronicity by identifying the synchronous rotating field frequency.

The "search" starts in positive direction.

Duration:

- The flying restart process is determined within approx. 0.5 ... 1.5 seconds.
- The duration is influenced by the start frequency P718:1.

Setting the function:

1. As starting performance, set the selection "Flying restart circuit [2]" in P203:1.
 - Thus, every VSD enable causes a synchronisation to the rotating or standing drive.
 - After the VSD has been enabled, the motor can temporarily start or reverse if drives with low friction and low mass inertia are used.
 - If the VSD is operated with the default settings, no further settings are required for most applications.
2. If required, adapt the current P718:1 and the start frequency P718:2 for the flying restart circuit.
 - Setting notes can be found in the "Info" column for the respective parameter.

For diagnostic purposes, the frequency detected when the motor has been restarted on the fly is displayed in P718:8.

P718:1	0x2BA1:1	Flying restart circuit: Current			
0 ... [30] ... 100 %		The current set here is injected into the motor during the flying restart process for the identification of the rotating field frequency. <ul style="list-style-type: none"> – 100 % = Motor rated current (P323:0) – Reducing the current causes a reduction of the motor torque during the flying restart process. A short-time starting action or reversing of the motor is prevented with low flying restart currents. – If the current is set too low, the rotating field frequency cannot be identified correctly. – If the current is increased, this improves the robustness of the flying restart circuit. – In case of high mass inertias and high speeds, the flying restart circuit may cause an overvoltage in the DC bus if no brake resistor is connected. In this case, the current must be reduced. 			
P718:2	0x2BA1:2	Flying restart circuit: Start frequency			
-599.0 ... [20.0] ... 599.0 Hz		The frequency set here defines the starting point for the flying restart process. <ul style="list-style-type: none"> – The search starts in positive direction. – The default setting is adjusted to standard asynchronous motors. – In case of systems with a known search speed (e.g. torque-controlled drive systems that are to synchronise to a defined speed), the start frequency can be adapted for reducing the flying restart time. 			
P718:3	0x2BA1:3	Flying restart circuit: Restart time			
1 ... [Type Code dependent] ... 60000 ms		Integration time for controlling the flying restart circuit.			
P718:8	0x2BA1:8	Flying restart circuit: Flying restart frequency			
Read only: x.x Hz		Display of the found frequency at which the motor has been successfully restarted on the fly.			

5.9.11 AUTOMATIC RESTART

Configuration of the restart behaviour after a fault.

i The settings have no impact on errors and warnings of the VSD.

P760:2	0x2839:2	Fault configuration: Restart delay			
0.0 ... [3.0] ... 1000.0 s		If a fault occurs, a restart is possible at the earliest after the time set here has elapsed.			
P760:3	0x2839:3	Fault configuration: Number of restart attempts			
0 ... [5] ... 255		Number of restart attempts after a fault. <ul style="list-style-type: none"> – 255 = unlimited number of restart attempts. 			
P760:4	0x2839:4	Fault configuration: Trouble counter reset time			
0.1 ... [5.0] ... 3600.0 s		Time of trouble-free operation after the expiry of which the fault counter is decreased by 1.			
P760:5	0x2839:5	Fault configuration: Trouble counter			
Read only		Display of the current fault counter content. <ul style="list-style-type: none"> – The counter content is increased by 1 after each restart attempt. 			

5.9.12 MAINS FAILURE CONTROL

In case of power failure, this function can decelerate the motor and use its rotational energy to maintain the DC-bus voltage for a certain period of time. This makes it possible to continue to let the motor run during a short-term failure of the mains voltage. After mains recovery, the operating status that was active before the failure is adopted again.

Details

A failure of the mains voltage causes a continuous DC-bus voltage drop. If the mains failure control is enabled in P721:1, it will get active if the DC-bus voltage falls below the activation threshold set in P721:2.

As soon as the mains failure control is active, the motor is decelerated. Now the rotational energy of the motor is used to maintain the DC-bus voltage above the error threshold for undervoltage until the motor is decelerated to standstill in a controlled way. This process is controlled by the DC-bus voltage controller.

P721:1	0x2D66:1	Mains failure control: Enable function			
0: Disabled 1: Enabled		1 = enable mains failure control.			
P721:2	0x2D66:2	Mains failure control: DC-bus activation level			
60 ... [Type Code dependet] ... 90 %		Threshold below which the mains failure control is activated if it is enabled (P721:1 = 1). – 100 % ≙ nominal DC-bus voltage Recommended setting: – In general: 5 ... 10 % above the error threshold for undervoltage (display in P208:3). – 230V devices: 72 % – 400/480V devices: 82 %			
P721:3	0x2D66:3	Mains failure control: Gain V-controller			
0.00001 ... [0.01000] ... 0.50000 Hz/V		Proportional gain of the DC-bus voltage controller			
P721:4	0x2D66:4	Mains failure control: Reset time V-controller			
5 ... [20] ... 2000 ms		Reset time of the DC-bus voltage controller.			
P721:5	0x2D66:5	Mains failure control: DC voltage setpoint			
80 ... [100] ... 110 %		Voltage setpoint onto which the DC-bus voltage is to be maintained. – 100 % ≙ nominal DC-bus voltage			
P721:6	0x2D66:6	Mains failure control: Setpoint ramp			
1 ... [20] ... 16000 ms		Acceleration time for the voltage setpoint set in P721:5. – The set acceleration time refers to the acceleration from 0 to 100 % of the nominal DC-bus voltage.			
P721:7	0x2D66:7	Mains failure control: Clear time			
1 ... [20] ... 60000 ms		After the DC-bus voltage has exceeded the activation threshold P721:2 (+hysteresis) again, the time set here must be elapsed before the mains failure control is deactivated again if the restart protection is not activated (default setting).			
P721:8	0x2D66:8	Mains failure control: Restart threshold			
0.0 ... [0.0] ... 599.0 Hz		Threshold for restart protection. Below the threshold set here no restart takes place after mains recovery.			
P721:9	0x2D66:9	Mains failure control: Status mains failure control			
Read only Bit 0: Control active Bit 1: I-Reset active		Bit coded display of the mains failure control status. Bit 0: Control active 1 ≙ mains failure control active. – The DC-bus voltage has fallen below the activation threshold (P721:2). – The bit is reset to 0 after the DC-bus voltage has exceeded the activation threshold (+hysteresis) again and the clear time set in P721:7 has elapsed. Bit 1: I-Reset active 1 ≙ I component of the speed controller of the motor control is reset. – Bit is set to 1 if bit 0 is set to 1 (mains failure control active). – Bit is reset to 0 if the frequency setpoint falls below 0.1 Hz.			

5.9.12.1 Activating the mains failure control

1. Set the selection "Enabled [1]" in P721:1.
2. Set the activation threshold in [%] with reference to the nominal DC-bus voltage in P721:2.
 - Recommended setting: 5 ... 10 % above the error threshold for undervoltage (display in P208:3).
3. Set the voltage setpoint onto which the DC-bus voltage is to be maintained in P721:5.
 - Recommended setting: 95 ... 100 % (of the nominal DC-bus voltage).

The mains failure control gets active with these settings if the DC-bus voltage falls below the activation threshold. The DC-bus voltage controller now generates the required operational energy from the rotational energy of the motor. The motor is decelerated by the mains failure control. Thus, the deceleration ramp is shorter than the one of a non-guided system (coasting drive).

After the mains failure control has been activated:

1. The DC-bus voltage is controlled with the acceleration time set in P721:6 to the setpoint set in P721:5.
2. An internally generated frequency setpoint is transferred to the motor control which enables the motor (via the frequency setpoint) to be decelerated to a frequency close to "0 Hz".
 - Starting value for the guided deceleration is the current output frequency.
 - The deceleration ramp (and hence the braking torque) results from the moment of inertia of the load machine(s), the power loss of the drive (system) and the set parameterisation.

Behaviour after mains recovery

If, after mains recovery, the DC-bus voltage has exceeded the activation threshold (+hysteresis) again, an internal timing element is started. After the time period set in P721:7 has elapsed, the mains failure control is stopped if the restart protection is not activated (default setting).

5.9.12.2 Restart protection

The integrated restart protection is to prevent a restart in the lower frequency range if the mains voltage was only interrupted briefly (mains recovery before the motor stands still).

- In the default setting P721:8 = 0 Hz, the restart protection is deactivated.
- In order to activate the restart protection, set the restart threshold in [Hz] in P721:8 below which no automatic start shall take place after mains recovery.
- If, in case of mains recovery, the output frequency is below the restart threshold, the restart protection gets active:
 - If the current DC-bus voltage is lower than the voltage setpoint P721:5, the motor is continued to be decelerated (until frequency 0 Hz).
 - If the current DC-bus voltage is higher than the voltage setpoint P721:5, the motor is accelerated in a controlled way until the output frequency exceeds the restart threshold.
- If, in case of mains recovery, the output frequency is above the restart threshold, the motor is accelerated again to the frequency setpoint.

Diagnostic parameters:

- An active restart protection is displayed via the status bit 0 in P721:9 if the mains failure control is not active.

Terminating the active restart protection

If, after mains recovery, the restart protection is active, it can be terminated by the following actions:

- Error reset via the trigger set in P400:4.
- Short-time VSD disable via the trigger set in P400:1.
- Restart via the trigger set in P400:2.

5.9.12.3 Fast mains recovery

A fast mains recovery is caused by a short interruption at the energy supply company (for instance due to a thunderstorm) and by faulty components in the supply cables (for instance slip rings).

The fast mains recovery causes a restart of the motor

- If the restart protection is deactivated (P721:8 = 0 Hz, default setting)
- or
- the restart protection does not get active (output frequency > P721:8).

If this behaviour is not desired, you can decelerate the restart by setting a switch-off time in P721:7 or prevent it in connection with the restart protection.

5.9.12.4 Commissioning the mains failure control

Commissioning should be executed with motors without load:

1. Let the motor rotate with a rated frequency of 100 %.
2. Disable the VSD and measure the time until the motor has reached standstill.
 - The time can be measured with a stop watch or similar.
 - If a motor encoder is connected to the VSD and set as feedback system for the motor control, this signal can be output at the analog output and measured with an oscilloscope.
3. Set the acceleration time for the voltage setpoint in P721:6 to approx. 1/10 of the time measured before.
4. Set the switch-off time n P721:7 to the time measured before.

Fine adjustment of the mains failure control

For the fine adjustment, you must repeat the following points several times:

1. An end frequency as low as possible should be reached before the VSD reaches the error threshold for undervoltage:
 - Increase the proportional gain of the DC-bus voltage controller in P721:3.
 - Reduce the reset time of the DC-bus voltage controller in P721:4.
2. If, during the mains failure control, monitoring for overvoltage in the DC bus is triggered:
 - Increase the reset time again in P721:4 until monitoring is not triggered anymore.
 - If required, additionally reduce the voltage setpoint in P721:5 onto which the DC-bus voltage is to be controlled.
3. Increasing the delay time or reducing the braking torque is only possible to a limited extent:
 - Increasing the acceleration time in P721:6 reduces the initial braking torque and simultaneously increases the deceleration time.
 - Increasing the reset time of the DC-bus voltage controller in P721:4 reduces the braking torque and simultaneously increases the deceleration time. If the reset time is too high, the VSD reaches the error threshold for undervoltage before standstill is reached. From this point on, the motor is not guided anymore.

5.9.13 POSITION COUNTER

This function counts the number of motor revolutions. The current counter content (actual position) can be output as process data via network to implement a simple position control in a higher-level Controller.

Preconditions

- An HTL encoder must be connected to and set at the digital inputs DI3/DI4.
- As an alternative, the number of motor revolutions from the motor model can be reconstructed. For this purpose, the motor control type "Sensorless control (SL PSM) [3]" must be selected and set in P300:0.
- The position control must be implemented in the Controller.

Details

The signal source for the position counter is selected in P711:1. The position counter can count forwards and backwards. The current counter content (actual position) is displayed in P711:3. After the maximum or minimum value has been reached, an overflow takes place.

Reset position counter:

- The position counter is reset when the supply voltage is switched on.
- The position counter can be set manually via the "Position counter reset" P400:54 function or the NetWordIN1 (P590:1) data word. For a reset via NetWordIN1, the "Position counter reset [54]" function must be assigned to a bit of the data word. Depending on the selection in P711:2, the reset can be made either edge-controlled or status-controlled.

P400:54	0x2631:54	Function list: Position counter reset			
0: Not connected (Reference see P400:1) Available from version 4.1		Assignment of a trigger for the "Position counter reset" function. Trigger = FALSE-TRUE edge: Reset position counter manually. Trigger = FALSE: no action. Notes: In P711:2 it can be selected whether the reset is to be effected edge-controlled (default setting) or status-controlled.			
P711:1	0x2C49:1	Position counter: Signal source			
0: Disabled 1: Feedback 1 (DI3/DI4) 5: Internal motor model Available from version 4.1		Selection of the signal source for the position counter. 0: Disabled Position counter is deactivated. 1: Feedback 1 (DI3/DI4) The motor revolutions are counted that are provided by an HTL encoder connected to the digital inputs DI3/DI4. - A motor revolution always equals to the increments/revolution set in P341:1 for the HTL encoder. This applies to all types of HTL encoders that can be set in P410:2: "HTL encoder (AB) [1]", "Pulse train [2]" and "Pulse train/direction [3]". - The counter content will be updated as well if the power section is switched off. - If an HTL encoder is used without detecting the direction of rotation, it is only counted forwards. 5: Internal motor model The motor revolutions reconstructed from the internal motor model of the sensorless control (SL PSM) are counted. - The counter content will not be updated if the power section is switched off. - After restarting the power section, the counting of the last counter content is continued.			
P711:2	0x2C49:2	Position counter: Reset mode			
0: Reset by rising edge 1: Reset by signal state true Available from version 4.1		Selection if the manual reset of the position counter is to be effected edge-controlled or status-controlled.			
P711:3	0x2C49:3	Position counter: Actual position			
Read only Available from version 4.1		Mappable parameter for providing the current counter content (actual position) via network. Scaling (applies to every measuring method or encoder resolution): - Upper 16 bits: Counted revolutions (0 ... 65535, overflow possible) - Lower 16 bits: Current position within the revolution (0 ... 65535)			

5.9.14 WRITE ACCESS PROTECTION

Optionally a write access protection can be installed for the VSD parameters.

i After activating the write access protection, you have to enter a valid PIN to remove the write access protection. Note down the defined PIN(s) and keep this information in a safe place! If you lose the PIN(s), the VSD can only be disabled by resetting it to the delivery status. This means, all parameter settings made by the user get lost!

The write access protection allows for the following configurations:

- Full write access
- Write access only to favorites or (when knowing PIN1) to all parameters
- No write access or (when knowing PIN2) full write access
- No write access or (when knowing PIN1) write access only to favorites or (when knowing PIN2) to all parameters

The following table compares the four possible configurations:

PIN1 setting	PIN2 setting	Log-in	Status display after log-in	Active write access protection
P730:0 0	P731:0 0	0x203F -	P197:0 0	No access protection configured.
Access →				
		Diagnostics (read access)	Favorites	All parameters
> 0	0	0 or wrong PIN	2	Write access only possible to favorites.
		Correct PIN1	0	Write access to all parameters possible.
Access →				
		Diagnostics (read access)	Favorites	All parameters PIN1
0	> 0	0 or wrong PIN	1	No write access.
		Correct PIN2	0	Write access to all parameters possible.
Access →				
		Diagnostics (read access)	Favorites	All parameters PIN2
> 0	> 0	0 or wrong PIN	1	No write access.
		Correct PIN1	2	Write access only possible to favorites.
		Correct PIN2	0	Write access to all parameters possible.
Access →				
		Diagnostics (read access)	Favorites	All parameters PIN1 PIN2
If PIN1 and PIN2 are set identically, a write access to all parameters is possible after the PIN has been entered correctly.				

P730:0	0x203D	PIN1 access protection			
-1 ... [0] ... 9999		Configure PIN1 for write access protection. - 1 ... 9999 = set/change PIN. - 0 = delete PIN (deactivate access protection). - When the PIN has been set successfully, the value -1 is shown; otherwise 0.			
P731:0	0x203E	PIN2 access protection			
-1 ... [0] ... 9999		Configure PIN2 for write access protection. - 1 ... 9999 = set/change PIN. - 0 = delete PIN (deactivate access protection). - When the PIN has been set successfully, the value -1 is shown; otherwise 0.			
P197:0	0x2040	Access protection status			
Read only Bit 0: No write access Bit 1: Only favorites changeable		Bit-coded display of the active access protection after login by PIN1/PIN2.			

5.9.15 FAVORITES SETUP

In order to gain quick access using VLBXSW01 or the keypad, frequently used parameters of the VSD can be defined as "Favorites".

- VLBXSW01 provides quick access to the "Favorites" via the Favorites tab.
- On the keypad, the "Favorites" can be found in Group 0. For the selection of favorite parameters via keypad, see parameters from P740:1 (Favorites settings: Parameter 1) to P740:50 (Favorites settings: Parameter 50).

P740:1	0x261C:1	Favorites settings: Parameter 1			
See parameter list		Definition of the Parameter 1 of "Favorites" parameters.			
P740:2	0x261C:2	Favorites settings: Parameter 2			
See parameter list		Definition of the Parameter 2 of "Favorites" parameters.			
P740:3	0x261C:3	Favorites settings: Parameter 3			
See parameter list		Definition of the Parameter 3 of "Favorites" parameters.			
...			
...	...				
P740:50	0x261C:50	Favorites settings: Parameter 50			
See parameter list		Definition of the Parameter 50 of "Favorites" parameters.			

5.9.16 PARAMETER CHANGE-OVER

The VSD supports several parameter sets. The parameter set can be selected by means of the device commands "Load parameter set 1" ... "Load parameter set 4".

DANGER!

Changed parameter settings can become effective immediately depending on the activating method set in P755:0.

The possible consequence is an unexpected response of the motor shaft while the VSD is enabled.

► If possible, only carry out parameter changes while the VSD is disabled.

► Certain device commands or settings which might cause a critical state of the drive behavior can generally only be carried out when the VSD is inhibited.

Details

The "parameter change-over" function provides a change-over between four sets with different parameter values for up to 32 freely selectable parameters.

The change-over via the device commands depends on the activation method set in P755:0:

– Activation method = 1 or 3: Change-over takes place immediately.

– Activation method = 0 or 2: The respective device command is only executed if the VSD is disabled.

The parameter list is compiled in the same way as that of the "Favorites" via configuration.

VLBXSW01 provides a user-friendly parameterisation dialog for this purpose.

P700:7	0x2022:7	Load parameter set 1			
0: Off / ready (Reference see P700:1)		1= load value set 1 of the "Parameter change-over" function. – The parameters specified in P750:1..P750:32 are set to the values set in P751:1..P751:32. – After successful execution, the value 0 is shown.			
P700:8	0x2022:8	Load parameter set 2			
0: Off / ready (Reference see P700:1)		1= load value set 2 of the "Parameter change-over" function. – The parameters specified in P750:1..P750:32 are set to the values set in P752:1..P752:32. – After successful execution, the value 0 is shown.			
P700:9	0x2022:9	Load parameter set 3			
0: Off / ready (Reference see P700:1)		1= load value set 3 of the "Parameter change-over" function. – The parameters specified in P750:1..P750:32 are set to the values set in P753:1..P753:32. – After successful execution, the value 0 is shown.			
P700:10	0x2022:10	Load parameter set 4			
0: Off / ready (Reference see P700:1)		1= load value set 4 of the "Parameter change-over" function. – The parameters specified in P750:1..P750:32 are set to the values set in P754:1..P754:32. – After successful execution, the value 0 is shown.			
P700:11	0x2022:11	Save parameter set 1			
0: Off / ready (Reference see P700:1)		1 = save value set 1 of the "Parameter change-over" function. – When the device command has been executed successfully, the value 0 is shown.			
P700:12	0x2022:12	Save parameter set 2			
0: Off / ready (Reference see P700:1)		1 = save value set 2 of the "Parameter change-over" function. – When the device command has been executed successfully, the value 0 is shown.			
P700:13	0x2022:13	Save parameter set 3			
0: Off / ready (Reference see P700:1)		1 = save value set 3 of the "Parameter change-over" function. – When the device command has been executed successfully, the value 0 is shown.			
P700:14	0x2022:14	Save parameter set 4			
0: Off / ready (Reference see P700:1)		1 = save value set 4 of the "Parameter change-over" function. – When the device command has been executed successfully, the value 0 is shown.			

P750:1	0x4041:1	Parameter change-over: Parameter 1			
0x00000000 ... [0x00000000] ... 0xFFFFF00		Parameter 1 of the list "Parameter change-over" function.			
P750:2	0x4041:2	Parameter change-over: Parameter 2			
0x00000000 ... [0x00000000] ... 0xFFFFF00		Parameter 2 of the list "Parameter change-over" function.			
...			
...			
P750:32	0x4041:32	Parameter change-over: Parameter 32			
0x00000000 ... [0x00000000] ... 0xFFFFF00		Parameter 32 of the list "Parameter change-over" function.			

P751:1	0x4042:1	Parameter value set 1: Value of parameter 1			
-2147483648 ... [0] ... 2147483647					
P751:2	0x4042:2	Parameter value set 1: Value of parameter 2			
-2147483648 ... [0] ... 2147483647					
...			
...			
P751:32	0x4042:32	Parameter value set 1: Value of parameter 32			
-2147483648 ... [0] ... 2147483647					

P752:1	0x4043:1	Parameter value set 2: Value of parameter 1			
-2147483648 ... [0] ... 2147483647					
P752:2	0x4043:2	Parameter value set 2: Value of parameter 2			
-2147483648 ... [0] ... 2147483647					
...			
...			
P752:32	0x4043:32	Parameter value set 2: Value of parameter 32			
-2147483648 ... [0] ... 2147483647					

P753:1	0x4044:1	Parameter value set 3: Value of parameter 1			
-2147483648 ... [0] ... 2147483647					
P753:2	0x4044:2	Parameter value set 3: Value of parameter 2			
-2147483648 ... [0] ... 2147483647					
...			
...			
P753:32	0x4044:32	Parameter value set 3: Value of parameter 32			
-2147483648 ... [0] ... 2147483647					

P754:1	0x4045:1	Parameter value set 4: Value of parameter 1			
-2147483648 ... [0] ... 2147483647					
P754:2	0x4045:2	Parameter value set 4: Value of parameter 2			
-2147483648 ... [0] ... 2147483647					
...			
...			
P754:32	0x4045:32	Parameter value set 4: Value of parameter 32			
-2147483648 ... [0] ... 2147483647					

P755:0	0x4046	Activation of parameter set			
0: Via command (disable required) 1: Via command (immediately) 2: If the selection is changed (disable required) 3: If the selection is changed (immediately)		<p>Selection of the activation method for the parameter change-over.</p> <p>If the selection is changed from "Via command... [0]/[1]" to "If the selection is changed...[2]/[3]" after switch-on, the parameter set selected via the functions "Select parameter set (bit 0)" and "Select parameter set (bit 1)" is activated immediately. In case of selection [2], however, this only takes place if the VSD is disabled, the motor is stopped or an error is active.</p> <p>0: Via command (disable required) The parameter set selected via the functions "Select parameter set (bit 0)" and "Select parameter set (bit 1)" is activated if the trigger assigned to the "Load parameter set" function in P400:40 provides a FALSE-TRUE edge AND the VSD is inhibited, the motor is stopped or an error is active.</p> <p>1: Via command (immediately) The parameter set selected via the functions "Select parameter set (bit 0)" and "Select parameter set (bit 1)" is immediately activated if the trigger assigned to the "Load parameter set" function in P400.40 provides a FALSE-TRUE edge.</p> <p>2: If the selection is changed (disable required) The parameter set selected via the functions "Select parameter set (bit 0)" and "Select parameter set (bit 1)" is activated if the state of these selection bits changes AND the VSD is inhibited, the motor is stopped or an error is active.</p> <p>3: If the selection is changed (immediately) The parameter set selected via the functions "Select parameter set (bit 0)" and "Select parameter set (bit 1)" is activated immediately if the state of these selection bits is changed.</p>			
P756:1	0x4047:1	Parameter change-over error message: Status			
Read only 0: No fault 33803: Invalid data type 33804: Range violation 33806: Invalid index 33813: No element selected 33815: Writing impermissible 33816: Device not inhibited 33829: Invalid subindex 33837: Access impermissible 33860: Parameter not mappable 33865: No subindexes 33876: Parameter not changeable		Error message for the "parameter change-over" function. <ul style="list-style-type: none"> - In the event of an error, an error status is shown here, and in 756:2 the number of the list entry in which the error has occurred is displayed (in connection with the value set selected). - If several errors occur at the same time, only the first incorrect list entry will be displayed. Hence, after limination of the displayed error and repeated activation, more errors may be displayed. - The parameter list will always be processed from beginning to end, even if errors occur in the meantime. 			
P756:2	0x4047:2	Parameter change-over error message: List entry			
Read only		Error message for the "Parameter set changeover" function. <ul style="list-style-type: none"> - In the event of an error, the number of the list entry for which the error displayed in P756:1 has occurred is shown here. 			

See also the following parameters (for details consult the chapter GROUP 4 – I/O SETUP):

P400:40 Load parameter set)

P400:41 Select parameter set (bit 0)

P400:42 Select parameter set (bit 1)

5.10 GROUP 8 – SEQUENCER

The "sequencer" function serves to transfer a programmed sequence of setpoints to the motor control. The switch-over to the next setpoint can be made time-controlled or even-controlled. Optionally, the "sequencer" function can also trigger the digital and analog outputs. Sequencer function is available from firmware 4.1.

i The sequencer only generates setpoints. However, the sequencer does not control the motor operation (does not output any start and stop commands).

Basics: Sequences, steps and segments

- As a total, 8 sequences can be configured (with the numbers 1 to 8).
- Each sequence consists of 16 configurable steps.
- Each step of a sequence can call a "segment".
 - A segment contains, among other things preset setpoints (speed setpoint, PID control value, torque setpoint), a combined acceleration/deceleration for the speed setpoint and optionally a configuration for the digital and analog outputs.
 - 8 different segments and one end segment can be configured.
- Alternatively to calling a single segment, a complete sequence (with a higher number) can also be called from one step. This serves to implement nested sequences or summarise several sequences to one sequence.

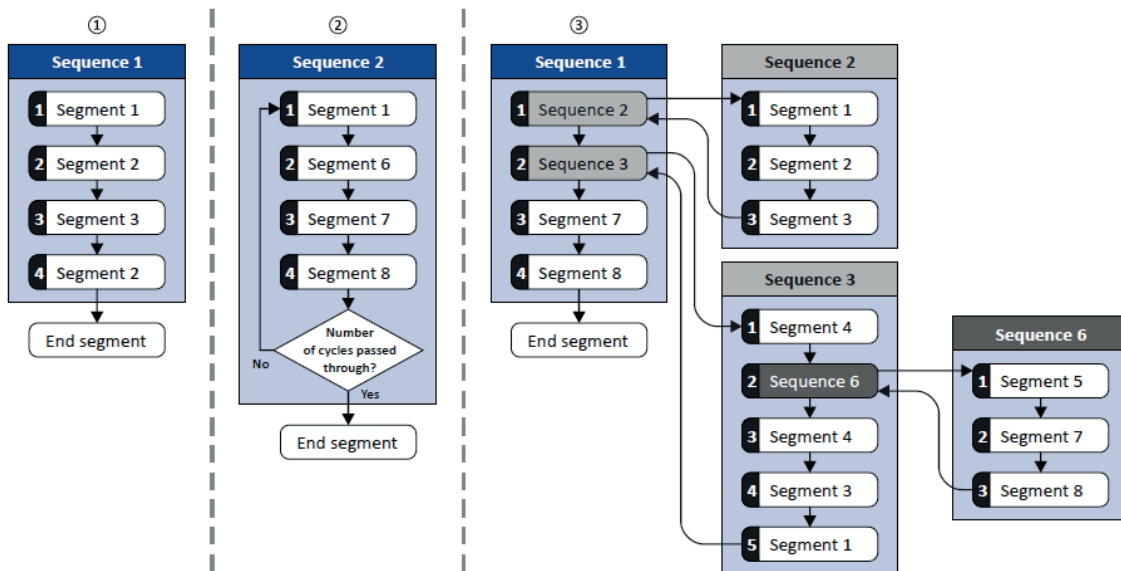

- ① Simple sequence with four steps.
- ② Simple sequence with four steps that are passed through several times (number of cycles > 1). For each sequence, the number of cycles can be set individually.
- ③ Nested sequence: Other (sub) sequences are called by one (main) sequence.

Commissioning

For commissioning the sequencer, we recommend the following proceeding:

1. Configure segments (including end segment).
Details: see chapter "Segment configuration".
2. Configure sequences:
 - a) Assign the segments to the single steps of a sequence.
 - b) Set the number of cycles for the respective sequence.
Details: See chapter "Sequence configuration".
3. Make the basic setting of the sequencer:
 - a) Set the desired operating mode (time and/or step operation).
 - b) Optionally: Adapt end of sequence mode and start of sequence mode.
Details: See chapter "Sequencer basic settings".
4. Configure the control of the sequencer:
 - a) Assign the functions for selecting a sequence to suitable triggers (e. g. digital inputs).
 - b) Assign the functions for controlling the sequencer (start, stop, cancel, ...) to suitable triggers.
Details: See chapter "Sequencer control functions".

Control

The functions listed in the following table serve to control the sequencer. For details, see chapter "Sequencer control functions".

Function	Info
Select sequence (bit 0) ... Select sequence (bit 3)	Bit coded selection of the sequence to be started.
Start sequence	The selected sequence is started. The start can take place edge or status-controlled depending on the configuration.
Next sequence step	Immediate jump to the next step irrespective of the time set for the segment
Pause sequence	The sequencer stops in the current step. The expiration for the time set for the segment is stopped. The sequencer setpoint remains active.
Suspend sequence	There is a temporal return to the normal setpoint control. The sequence is then continued at the point where it was suspended.
Stop sequence	Direct jump to the end segment. The further execution depends on the selected end of sequence mode.
Abort sequence	Immediate return to the normal setpoint control. The end segment is not executed anymore.

Diagnostics

For diagnosing the sequencer, the diagnostic parameters listed in chapter "Sequencer diagnostics" are available.

Internal status signals

The sequencer provides different internal status signals (see the following table). These status signals can be assigned to the relay, the digital outputs or the status word.

Function	Info
"Sequencer controlled [100]"	The control is executed via the sequencer (according to the configuration of the digital outputs for the current segment).
"Sequence active [101]"	The sequence is running and is currently not suspended.
"Sequence suspended [102]"	The sequence is currently suspended.
"Sequence done [103]"	The sequence is completed (end segment was passed through).

5.10.1 Segment configuration

Each step of a sequence can call a "segment". A segment contains, among other things preset setpoints (speed setpoint, PID control value, torque setpoint), a combined acceleration/deceleration for the speed setpoint and optionally a configuration for the digital and analog outputs.

As a total, 8 segments and one end segment can be configured.

- The settings are only effective if a sequence is active and the respective segment is executed.
- Not all settings are relevant for all operating modes. If, for instance, the PID control is not used at all, no PID setpoint needs to be set for the segment.
- The following figure shows the segment settings relevant for the operating mode P301:0 = "MS: Velocity mode [-2]".
- The table below contains a short overview of the possible settings for each segment.

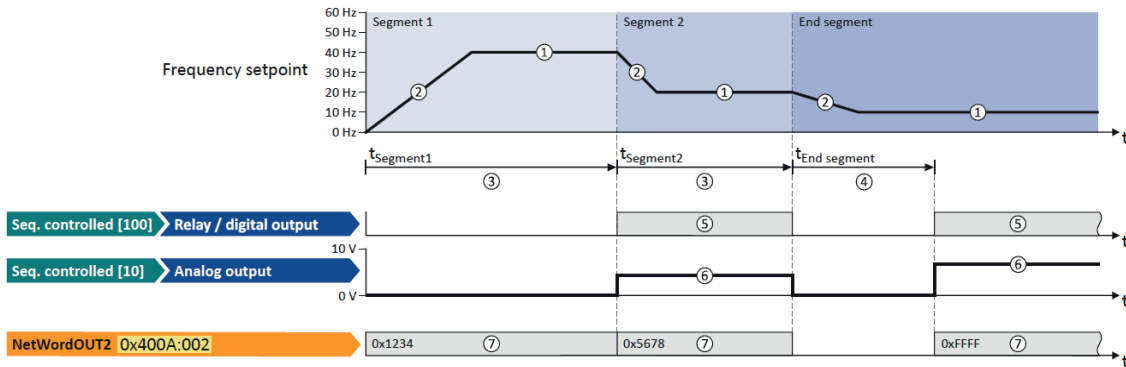

Setting		Info
Frequency setpoint	①	Only relevant for the operating mode P301:0 = "MS: Velocity mode [-2]". Direction of rotation according to sign.
Acceleration/deceleration	②	Only relevant for operating mode P301:0 = "MS: Velocity mode [-2]". The set time refers to the acceleration from standstill to the set maximum frequency. The deceleration is effected with the same ramp.
Time	③	Meaning for segment 1 ... 8: Runtime for the segment after the expiry of which it is switched over to the next step of the sequence. Only relevant for Sequencer mode P800:0 = "Time operation [1]" or "Time & step operation [3]".
	④	Meaning for end segment: Delay time for activating the output states configured for the end segment.
Digital outputs	⑤	Optionally: Set digital outputs to a certain level for the execution time of the segment.
Analog outputs	⑥	Optionally: Set analog outputs to an adjustable voltage value for the execution time of the segment.
PID setpoint		Only relevant if the PID control in P600:1 is activated.
Torque setpoint		Only relevant for operating mode P301:0 = "MS: Torque mode [-1]".
NetWordOUT2	⑦	Optionally: Set NetWordOUT2 data word for the execution time of the segment to an adjustable value. The NetWordOUT2 data word P591:2 can be mapped to a network register to transfer the set value as process data.

In the following, all parameters relevant for the segment configuration are given.

i If the sequencer is active, write access to all parameters are blocked that concern the active segment configuration!

P801:1	0x4026:1	Sequencer segment 1: Frequency setpoint			
599.0 ... [0.0] ... 599.0 Hz		Frequency setpoint for the segment. – Only relevant for operating mode P301:0 = "MS: Velocity mode [-2]". – Direction of rotation according to sign.			
P801:2	0x4026:2	Sequencer segment 1: Acceleration/deceleration			
0.0 ... [5.0] ... 3600.0 s		Acceleration/deceleration for the segment. – Only relevant for operating mode P301:0 = "MS: Velocity mode [-2]". – The set time refers to the acceleration from standstill to the set maximum frequency. The deceleration is effected with the same ramp.			
P801:3	0x4026:3	Sequencer segment 1: Time			
0.0 ... [0.0] ... 100000.0 s		Runtime for the segment after the expiry of which it is switched over to the next step of the sequence. – Only relevant for Sequencer mode P800:0 = "Time operation [1]" or "Time & step operation [3]". – With the setting "0.0", the segment will be skipped.			
P801:4	0x4026:4	Sequencer segment 1: Digital outputs			
0 ... [0] ... 255 Bit 0: Relay Bit 1: Digital output 1	–	Optionally: Set digital outputs to the level set here for the execution time of the segment. Note! In order that the control of a digital output is executed by the sequencer, the following assignment must be made for the respective digital output: Relay: P420:1 = "Sequencer controlled [100]" – Digital output 1: P420:2 = "Sequencer controlled [100]" Bit 0: Relay 0 = X9/NO-COM open and NC-COM closed. 1 = X9/NO-COM closed and NC-COM open. An inversion set in P421:1 is taken into consideration here. Bit 1: Digital output 1 0 = set digital output 1 to LOW level. 1 = set digital output 1 to HIGH level. An inversion set in P421:2 is taken into consideration here.			
P801:5	0x4026:5	Sequencer segment 1: Analog outputs			
0.00 ... [0.00] ... 10.00 VDC		Optionally: Set analog output to the voltage value set here for the execution time of the segment. Note! In order that the control of an analog output is executed by the sequencer, the following assignment must be made: – Analog output 1: P440:2 = "Sequencer controlled [10]"			
P801:6	0x4026:6	Sequencer segment 1: PID setpoint			
-300.00 ... [0.00] ... 300.00 PID unit		PID control value for the segment. – Only relevant if the PID control in P600:1 is activated.			
P801:7	0x4026:7	Sequencer segment 1: Torque setpoint			
-400.0 ... [100.0] ... 400.0 %		Torque setpoint for the segment. – Only relevant for operating mode P301:0 = "MS: Torque mode [-1]".			

To program the Sequencer segments 2/3/4/5/6/7/8:

- Sequencer segment 2: see parameters from P802:1 to P802:7.
- Sequencer segment 3: see parameters from P803:1 to P803:7.
- Sequencer segment 4: see parameters from P804:1 to P804:7.
- Sequencer segment 5: see parameters from P805:1 to P805:7.
- Sequencer segment 6: see parameters from P806:1 to P806:7.
- Sequencer segment 7: see parameters from P807:1 to P807:7.
- Sequencer segment 8: see parameters from P808:1 to P808:7.

These parameters have the same meaning of the parameters of Sequencer segment 1 listed above (P801:1 ... P801:7) but are valid for Sequencer segment 2/3/4/5/6/7/8.

P822:1	0x402E:1	End segment: Frequency setpoint			
-599.0 ... [0.0] ... 599.0 Hz		Frequency setpoint after the sequence has been completed, i. e., after the steps configured for the sequence have been passed through with the set numbers of cycles. – Only relevant for the operating mode P301:0 = "MS: Velocity mode [-2]" and if end of sequence mode P824:0 = "Keep running [0]". – Direction of rotation according to sign.			
P822:2	0x402E:2	End segment: Acceleration/deceleration			
0.0 ... [5.0] ... 3600.0 s		If end of sequence mode = "continuous operation" (default setting): Acceleration/deceleration for reaching the frequency setpoint set for the end segment after the sequence has been processed. If end of sequence mode = "Stop" or "Stop and abort": Deceleration for reaching standstill after the sequence has been processed. – Only relevant for operating mode P301:0 = "MS: Velocity mode [-2]". – The set time refers to the acceleration from standstill to the set maximum frequency. The deceleration is effected with the same ramp.			
P822:3	0x402E:3	End segment: Time			
0.0 ... [0.0] ... 100000.0 s		Delay time for activating the output states configured for the end segment. – This parameter has a different meaning than the time settings for the segments 1 ... 8! – The set deceleration time starts when the end segment is started to be processed. After the deceleration time has elapsed: – The digital outputs are (if configured accordingly) set to the levels set in P822:4. – The analog outputs are (if configured accordingly) set to the voltage value set in P822:5. – The NetWordOUT2 data word is set to the value set in 0x402E:008.			

P822:4	0x402E:4	End segment: Digital outputs			
0 ... [0] ... 255		Optionally: Set digital outputs to the levels set here after the time set for the end segment.			
Bit 0: Relay Bit 1: Digital output 1		Bit 0: Relay 0 = X9/NO-COM open and NC-COM closed. 1 = X9/NO-COM closed and NC-COM open. An inversion set in P421:1 is taken into consideration here. Bit 1: Digital output 1 0 = set digital output 1 to LOW level. 1 = set digital output 1 to HIGH level. An inversion set in P421:2 is taken into consideration here.			
P822:5	0x402E:5	End segment: Analog outputs			
0.00 ... [0.00] ... 10.00 VDC		Optionally: Set analog output to the voltage value set here after the time set for the end segment. Note! In order that the control of an analog output is executed by the sequencer, the following assignment must be made: – Analog output 1: P440:2 = "Sequencer controlled [10]"			
P822:6	0x402E:6	End segment: PID setpoint			
-300.00 ... [0.00] ... 300.00 PID unit		PID control value after the sequence has been completed, i. e., after the steps configured for the sequence have been passed through with the set numbers of cycles. – Only relevant if PID control is activated in P600:1 and end of sequence mode P824:0 = "Keep running [0]".			
P822:7	0x402E:7	End segment: Torque setpoint			
-400.0 ... [100.0] ... 400.0 %		Torque setpoint after the sequence has been completed, i. e., after the steps configured for the sequence have been passed through with the set numbers of cycles. – Only relevant for the operating mode P301:0 = "MS: Torque mode [-1]" and if end of sequence mode P824:0 = "Keep running [0]".			

5.10.2 Sequence configuration

As a total, 8 sequences can be configured (with the numbers 1 to 8). Each sequence consists of 16 configurable steps. Each step of a sequence can call a segment or a complete sequence (with a higher number).

The following example illustrates the configuration based on a nested sequence:

- The sequence 1 is the main sequence which calls further (sub) sequences.
- The main sequence is passed through four times. Afterwards, in the preset "continuous operation" end of sequence mode, the setpoint set for the end segment is continuously transmitted to the motor control until the sequence is aborted.

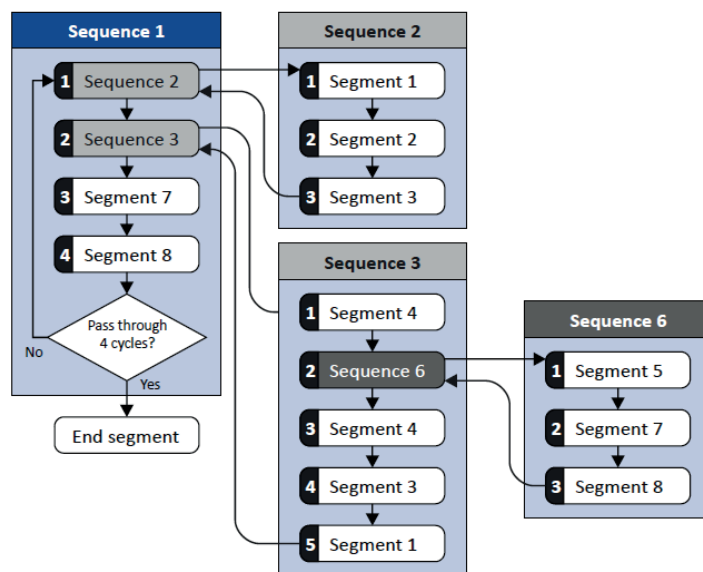

Resulting segment order												
1	2	3	4	5	7	8	4	3	1	7	8	End segment
4 cycles												

Require parameter setting:

	Sequence 1	Sequence 2
Step 1	P830:1 = "Sequence 2 [-2]"	P835:1 = "Segment 1 [1]"
Step 2	P830:2 = "Sequence 3 [-3]"	P835:2 = "Segment 2 [2]"
Step 3	P830:3 = "Segment 7 [7]"	P835:3 = "Segment 3 [3]"
Step 4	P830:4 = "Segment 8 [8]"	P835:4 = "Skip step [0]"
Step 5	P830:5 = "Skip step [0]"	...
Step	
Step 16	P830:16 = Skip step [0]"	P835:16 = Skip step [0]"
Number of cycles	P831:0 = 4	P836:0 = 1

	Sequence 3	Sequence 6
Step 1	P840:1 = "Segment 4 [4]"	P855:1 = "Segment 5 [5]"
Step 2	P840:2 = "Sequence 6 [-6]"	P855:2 = "Segment 7 [7]"
Step 3	P840:3 = "Segment 4 [4]"	P855:3 = "Segment 8 [8]"
Step 4	P840:4 = "Segment 3 [3]"	P855:4 = "Skip step [0]"
Step 5	P840:5 = "Segment 1 [1]"	...
Step 6	P840:6 = Skip step [0]"	
Step	
Step 16	P840:16 = Skip step [0]"	P855:16 = Skip step [0]"
Number of cycles	P841:0 = 1	P856:0 = 1

In the following, all parameters relevant for the sequence configuration are given.

i If the sequencer is active, write accessed to all parameters are blocked that concern the active sequence configuration!

P830:1	0x4030:1	Sequence 1: Step 1			
-8 : Sequence 8 -7 : Sequence 7 -6 : Sequence 6 -5 : Sequence 5 -4 : Sequence 4 -3 : Sequence 3 -2 : Sequence 2 0 : Skip step 1 : Segment 1 2 : Segment 2 3 : Segment 3 4 : Segment 4 5 : Segment 5 6 : Segment 6 7 : Segment 7 8 : Segment 8		Configuration of the step 1 for sequence 1. - Alternatively to calling a single segment, a complete sequence (with a higher number) can also be called from one step. This, for instance, serves to configure a main sequence from which several subsequences are called successively. - With the setting "0", the respective step is skipped.			
P830:2	0x4030:2	Sequence 1: Step 2			
0: Skip step (Reference: see P830:1)		Configuration of the step 2 for sequence 1.			
P830:3	0x4030:3	Sequence 1: Step 3			
0: Skip step (Reference: see P830:1)		Configuration of the step 3 for sequence 1.			
P830:4	0x4030:4	Sequence 1: Step 4			
0: Skip step (Reference: see P830:1)		Configuration of the step 4 for sequence 1.			
P830:5	0x4030:5	Sequence 1: Step 5			
0: Skip step (Reference: see P830:1)		Configuration of the step 5 for sequence 1.			
P830:6	0x4030:6	Sequence 1: Step 6			
0: Skip step (Reference: see P830:1)		Configuration of the step 6 for sequence 1.			
P830:7	0x4030:7	Sequence 1: Step 7			
0: Skip step (Reference: see P830:1)		Configuration of the step 7 for sequence 1.			
P830:8	0x4030:8	Sequence 1: Step 8			
0: Skip step (Reference: see P830:1)		Configuration of the step 8 for sequence 1.			
P830:9	0x4030:9	Sequence 1: Step 9			
0: Skip step (Reference: see P830:1)		Configuration of the step 9 for sequence 1.			
P830:10	0x4030:10	Sequence 1: Step 10			
0: Skip step (Reference: see P830:1)		Configuration of the step 10 for sequence 1.			
P830:11	0x4030:11	Sequence 1: Step 11			
0: Skip step (Reference: see P830:1)		Configuration of the step 11 for sequence 1.			

P830:12	0x4030:12	Sequence 1: Step 12			
0: Skip step (Reference: see P830:1)		Configuration of the step 12 for sequence 1.			
P830:13	0x4030:13	Sequence 1: Step 13			
0: Skip step (Reference: see P830:1)		Configuration of the step 13 for sequence 1.			
P830:14	0x4030:14	Sequence 1: Step 14			
0: Skip step (Reference: see P830:1)		Configuration of the step 14 for sequence 1.			
P830:15	0x4030:15	Sequence 1: Step 15			
0: Skip step (Reference: see P830:1)		Configuration of the step 15 for sequence 1.			
P830:16	0x4030:16	Sequence 1: Step 16			
0: Skip step (Reference: see P830:1)		Configuration of the step 16 for sequence 1.			
P831:0	0x4031	Number of cycles sequence 1			
1 ... [1] ... 65535		Definition of how often the sequence 1 is to be passed through. <ul style="list-style-type: none"> - 1 = one pass, 2 = two passes, ... - 65535 = infinite number of cycles. 			

P835:1	0x4032:1	Sequence 2: Step 1			
-8 : Sequence 8 -7 : Sequence 7 -6 : Sequence 6 -5 : Sequence 5 -4 : Sequence 4 -3 : Sequence 3 0: Skip step 1: Segment 1 2: Segment 2 3: Segment 3 4: Segment 4 5: Segment 5 6: Segment 6 7: Segment 7 8: Segment 8		Configuration of the step 1 for sequence 2. <ul style="list-style-type: none"> - Alternatively to calling a single segment, a complete sequence (with a higher number) can also be called from one step. This, for instance, serves to configure a main sequence from which several subsequences are called successively. - With the setting "0", the respective step is skipped. 			
P835:2	0x4032:2	Sequence 2: Step 2			
0: Skip step (Reference: see P835:1)		Configuration of the step 2 for sequence 2.			
P835:3	0x4032:3	Sequence 2: Step 3			
0: Skip step (Reference: see P835:1)		Configuration of the step 3 for sequence 2.			
P835:4	0x4032:4	Sequence 2: Step 4			
0: Skip step (Reference: see P835:1)		Configuration of the step 4 for sequence 2.			
P835:5	0x4032:5	Sequence 2: Step 5			
0: Skip step (Reference: see P835:1)		Configuration of the step 5 for sequence 2.			
P835:6	0x4032:6	Sequence 2: Step 6			
0: Skip step (Reference: see P835:1)		Configuration of the step 6 for sequence 2.			
P835:7	0x4032:7	Sequence 2: Step 7			
0: Skip step (Reference: see P835:1)		Configuration of the step 7 for sequence 2.			
P835:8	0x4032:8	Sequence 2: Step 8			
0: Skip step (Reference: see P835:1)		Configuration of the step 8 for sequence 2.			
P835:9	0x4032:9	Sequence 2: Step 9			
0: Skip step (Reference: see P835:1)		Configuration of the step 9 for sequence 2.			
P835:10	0x4032:10	Sequence 2: Step 10			
0: Skip step (Reference: see P835:1)		Configuration of the step 10 for sequence 2.			
P835:11	0x4032:11	Sequence 2: Step 11			
0: Skip step (Reference: see P835:1)		Configuration of the step 11 for sequence 2.			
P835:12	0x4032:12	Sequence 2: Step 12			
0: Skip step (Reference: see P835:1)		Configuration of the step 12 for sequence 2.			
P835:13	0x4032:13	Sequence 2: Step 13			
0: Skip step (Reference: see P835:1)		Configuration of the step 13 for sequence 2.			
P835:14	0x4032:14	Sequence 2: Step 14			
0: Skip step (Reference: see P835:1)		Configuration of the step 14 for sequence 2.			

P835:15	0x4032:15	Sequence 2: Step 15			
0: Skip step (Reference: see P835:1)		Configuration of the step 15 for sequence 2.			
P835:16	0x4032:16	Sequence 2: Step 16			
0: Skip step (Reference: see P835:1)		Configuration of the step 16 for sequence 2.			
P836:0	0x403	Number of cycles sequence 2			
1 ... [1] ... 65535		Definition of how often the sequence 2 is to be passed through. – 1 = one pass, 2 = two passes, ... – 65535 = infinite number of cycles.			
P840:1	0x4034:1	Sequence 3: Step 1			
-8 : Sequence 8 -7 : Sequence 7 -6 : Sequence 6 -5 : Sequence 5 -4 : Sequence 4 0: Skip step 1: Segment 1 2: Segment 2 3: Segment 3 4: Segment 4 5: Segment 5 6: Segment 6 7: Segment 7 8: Segment 8		Configuration of the step 1 for sequence 3. – Alternatively to calling a single segment, a complete sequence (with a higher number) can also be called from one step. This, for instance, serves to configure a main sequence from which several subsequences are called successively. – With the setting "0", the respective step is skipped.			
P840:2	0x4034:2	Sequence 3: Step 2			
0: Skip step (Reference: see P840:1)		Configuration of the step 2 for sequence 3.			
P840:3	0x4034:3	Sequence 3: Step 3			
0: Skip step (Reference: see P840:1)		Configuration of the step 3 for sequence 3.			
P840:4	0x4034:4	Sequence 3: Step 4			
0: Skip step (Reference: see P840:1)		Configuration of the step 4 for sequence 3.			
P840:5	0x4034:5	Sequence 3: Step 5			
0: Skip step (Reference: see P840:1)		Configuration of the step 5 for sequence 3.			
P840:6	0x4034:6	Sequence 3: Step 6			
0: Skip step (Reference: see P840:1)		Configuration of the step 6 for sequence 3.			
P840:7	0x4034:7	Sequence 3: Step 7			
0: Skip step (Reference: see P840:1)		Configuration of the step 7 for sequence 3.			
P840:8	0x4034:8	Sequence 3: Step 8			
0: Skip step (Reference: see P840:1)		Configuration of the step 8 for sequence 3.			
P840:9	0x4034:9	Sequence 3: Step 9			
0: Skip step (Reference: see P840:1)		Configuration of the step 9 for sequence 3.			
P840:10	0x4034:10	Sequence 3: Step 10			
0: Skip step (Reference: see P840:1)		Configuration of the step 10 for sequence 3.			
P840:11	0x4034:11	Sequence 3: Step 11			
0: Skip step (Reference: see P840:1)		Configuration of the step 11 for sequence 3.			
P840:12	0x4034:12	Sequence 3: Step 12			
0: Skip step (Reference: see P840:1)		Configuration of the step 12 for sequence 3.			
P840:13	0x4034:13	Sequence 3: Step 13			
0: Skip step (Reference: see P840:1)		Configuration of the step 13 for sequence 3.			
P840:14	0x4034:14	Sequence 3: Step 14			
0: Skip step (Reference: see P840:1)		Configuration of the step 14 for sequence 3.			
P840:15	0x4034:15	Sequence 3: Step 15			
0: Skip step (Reference: see P840:1)		Configuration of the step 15 for sequence 3.			
P840:16	0x4034:16	Sequence 3: Step 16			
0: Skip step (Reference: see P840:1)		Configuration of the step 16 for sequence 3.			
P841:0	0x4035	Number of cycles sequence 3			
1 ... [1] ... 65535		Definition of how often the sequence 3 is to be passed through. – 1 = one pass, 2 = two passes, ... – 65535 = infinite number of cycles.			

P845:1	0x4036:1	Sequence 4: Step 1			
-8 : Sequence 8 -7 : Sequence 7 -6 : Sequence 6 -5 : Sequence 5 0 : Skip step 1 : Segment 1 2 : Segment 2 3 : Segment 3 4 : Segment 4 5 : Segment 5 6 : Segment 6 7 : Segment 7 8 : Segment 8		Configuration of the step 1 for sequence 4. – Alternatively to calling a single segment, a complete sequence (with a higher number) can also be called from one step. This, for instance, serves to configure a main sequence from which several subsequences are called successively. – With the setting "0", the respective step is skipped.			
P845:2	0x4036:2	Sequence 4: Step 2			
0: Skip step (Reference: see P845:1)		Configuration of the step 2 for sequence 4.			
P845:3	0x4036:3	Sequence 4: Step 3			
0: Skip step (Reference: see P845:1)		Configuration of the step 3 for sequence 4.			
P845:4	0x4036:4	Sequence 4: Step 4			
0: Skip step (Reference: see P845:1)		Configuration of the step 4 for sequence 4.			
P845:5	0x4036:5	Sequence 4: Step 5			
0: Skip step (Reference: see P845:1)		Configuration of the step 5 for sequence 4.			
P845:6	0x4036:6	Sequence 4: Step 6			
0: Skip step (Reference: see P845:1)		Configuration of the step 6 for sequence 4.			
P845:7	0x4036:7	Sequence 4: Step 7			
0: Skip step (Reference: see P845:1)		Configuration of the step 7 for sequence 4.			
P845:8	0x4036:8	Sequence 4: Step 8			
0: Skip step (Reference: see P845:1)		Configuration of the step 8 for sequence 4.			
P845:9	0x4036:9	Sequence 4: Step 9			
0: Skip step (Reference: see P845:1)		Configuration of the step 9 for sequence 4.			
P845:10	0x4036:10	Sequence 4: Step 10			
0: Skip step (Reference: see P845:1)		Configuration of the step 10 for sequence 4.			
P845:11	0x4036:11	Sequence 4: Step 11			
0: Skip step (Reference: see P845:1)		Configuration of the step 11 for sequence 4.			
P845:12	0x4036:12	Sequence 4: Step 12			
0: Skip step (Reference: see P845:1)		Configuration of the step 12 for sequence 4.			
P845:13	0x4036:13	Sequence 4: Step 13			
0: Skip step (Reference: see P845:1)		Configuration of the step 13 for sequence 4.			
P845:14	0x4036:14	Sequence 4: Step 14			
0: Skip step (Reference: see P845:1)		Configuration of the step 14 for sequence 4.			
P845:15	0x4036:15	Sequence 4: Step 15			
0: Skip step (Reference: see P845:1)		Configuration of the step 15 for sequence 4.			
P845:16	0x4036:16	Sequence 4: Step 16			
0: Skip step (Reference: see P845:1)		Configuration of the step 16 for sequence 4.			
P846:0	0x4037	Number of cycles sequence 4			
1 ... [1] ... 65535		Definition of how often the sequence 4 is to be passed through. – 1 = one pass, 2 = two passes, ... – 65535 = infinite number of cycles.			

P850:1	0x4038:1	Sequence 5: Step 1			
-8 : Sequence 8 -7 : Sequence 7 -6: Sequence 6 0: Skip step 1: Segment 1 2: Segment 2 3: Segment 3 4: Segment 4 5: Segment 5 6: Segment 6 7: Segment 7 8: Segment 8		Configuration of the step 1 for sequence 5. – Alternatively to calling a single segment, a complete sequence (with a higher number) can also be called from one step. This, for instance, serves to configure a main sequence from which several subsequences are called successively. – With the setting "0", the respective step is skipped.			
P850:2	0x4038:2	Sequence 5: Step 2			
0: Skip step (Reference: see P850:1)		Configuration of the step 2 for sequence 5.			
P850:3	0x4038:3	Sequence 5: Step 3			
0: Skip step (Reference: see P850:1)		Configuration of the step 3 for sequence 5.			
P850:4	0x4038:4	Sequence 5: Step 4			
0: Skip step (Reference: see P850:1)		Configuration of the step 4 for sequence 5.			
P850:5	0x4038:5	Sequence 5: Step 5			
0: Skip step (Reference: see P850:1)		Configuration of the step 5 for sequence 5.			
P850:6	0x4038:6	Sequence 5: Step 6			
0: Skip step (Reference: see P850:1)		Configuration of the step 6 for sequence 5.			
P850:7	0x4038:7	Sequence 5: Step 7			
0: Skip step (Reference: see P850:1)		Configuration of the step 7 for sequence 5.			
P850:8	0x4038:8	Sequence 5: Step 8			
0: Skip step (Reference: see P850:1)		Configuration of the step 8 for sequence 5.			
P850:9	0x4038:9	Sequence 5: Step 9			
0: Skip step (Reference: see P850:1)		Configuration of the step 9 for sequence 5.			
P850:10	0x4038:10	Sequence 5: Step 10			
0: Skip step (Reference: see P850:1)		Configuration of the step 10 for sequence 5.			
P850:11	0x4038:11	Sequence 5: Step 11			
0: Skip step (Reference: see P850:1)		Configuration of the step 11 for sequence 5.			
P850:12	0x4038:12	Sequence 5: Step 12			
0: Skip step (Reference: see P850:1)		Configuration of the step 12 for sequence 5.			
P850:13	0x4038:13	Sequence 5: Step 13			
0: Skip step (Reference: see P850:1)		Configuration of the step 13 for sequence 5.			
P850:14	0x4038:14	Sequence 5: Step 14			
0: Skip step (Reference: see P850:1)		Configuration of the step 14 for sequence 5.			
P850:15	0x4038:15	Sequence 5: Step 15			
0: Skip step (Reference: see P850:1)		Configuration of the step 15 for sequence 5.			
P850:16	0x4038:16	Sequence 5: Step 16			
0: Skip step (Reference: see P850:1)		Configuration of the step 16 for sequence 5.			
P851:0	0x4039	Number of cycles sequence 5			
1 ... [1] ... 65535		Definition of how often the sequence 5 is to be passed through. – 1 = one pass, 2 = two passes, ... – 65535 = infinite number of cycles.			

P855:1	0x403A:1	Sequence 6: Step 1			
-8 : Sequence 8 -7 : Sequence 7 0: Skip step 1: Segment 1 2: Segment 2 3: Segment 3 4: Segment 4 5: Segment 5 6: Segment 6 7: Segment 7 8: Segment 8		Configuration of the step 1 for sequence 6. – Alternatively to calling a single segment, a complete sequence (with a higher number) can also be called from one step. This, for instance, serves to configure a main sequence from which several subsequences are called successively. – With the setting "0", the respective step is skipped.			
P855:2	0x403A:2	Sequence 6: Step 2			
0: Skip step (Reference: see P855:1)		Configuration of the step 2 for sequence 6.			
P855:3	0x403A:3	Sequence 6: Step 3			
0: Skip step (Reference: see P855:1)		Configuration of the step 3 for sequence 6.			
P855:4	0x403A:4	Sequence 6: Step 4			
0: Skip step (Reference: see P855:1)		Configuration of the step 4 for sequence 6.			
P855:5	0x403A:5	Sequence 6: Step 5			
0: Skip step (Reference: see P855:1)		Configuration of the step 5 for sequence 6.			
P855:6	0x403A:6	Sequence 6: Step 6			
0: Skip step (Reference: see P855:1)		Configuration of the step 6 for sequence 6.			
P855:7	0x403A:7	Sequence 6: Step 7			
0: Skip step (Reference: see P855:1)		Configuration of the step 7 for sequence 6.			
P855:8	0x403A:8	Sequence 6: Step 8			
0: Skip step (Reference: see P855:1)		Configuration of the step 8 for sequence 6.			
P855:9	0x403A:9	Sequence 6: Step 9			
0: Skip step (Reference: see P855:1)		Configuration of the step 9 for sequence 6.			
P855:10	0x403A:10	Sequence 6: Step 10			
0: Skip step (Reference: see P855:1)		Configuration of the step 10 for sequence 6.			
P855:11	0x403A:11	Sequence 6: Step 11			
0: Skip step (Reference: see P855:1)		Configuration of the step 11 for sequence 6.			
P855:12	0x403A:12	Sequence 6: Step 12			
0: Skip step (Reference: see P855:1)		Configuration of the step 12 for sequence 6.			
P855:13	0x403A:13	Sequence 6: Step 13			
0: Skip step (Reference: see P855:1)		Configuration of the step 13 for sequence 6.			
P855:14	0x403A:14	Sequence 6: Step 14			
0: Skip step (Reference: see P855:1)		Configuration of the step 14 for sequence 6.			
P855:15	0x403A:15	Sequence 6: Step 15			
0: Skip step (Reference: see P855:1)		Configuration of the step 15 for sequence 6.			
P855:16	0x403A:16	Sequence 6: Step 16			
0: Skip step (Reference: see P855:1)		Configuration of the step 16 for sequence 6.			
P856:0	0x403B	Number of cycles sequence 6			
1 ... [1] ... 65535		Definition of how often the sequence 6 is to be passed through. – 1 = one pass, 2 = two passes, ... – 65535 = infinite number of cycles.			

P860:1	0x403C:1	Sequence 7: Step 1			
-8 : Sequence 8 0: Skip step 1: Segment 1 2: Segment 2 3: Segment 3 4: Segment 4 5: Segment 5 6: Segment 6 7: Segment 7 8: Segment 8		Configuration of the step 1 for sequence 7. – Alternatively to calling a single segment, a complete sequence (with a higher number) can also be called from one step. This, for instance, serves to configure a main sequence from which several subsequences are called successively. – With the setting "0", the respective step is skipped.			
P860:2	0x403C:2	Sequence 7: Step 2			
0: Skip step (Reference: see P860:1)		Configuration of the step 2 for sequence 7.			
P860:3	0x403C:3	Sequence 7: Step 3			
0: Skip step (Reference: see P860:1)		Configuration of the step 3 for sequence 7.			
P860:4	0x403C:4	Sequence 7: Step 4			
0: Skip step (Reference: see P860:1)		Configuration of the step 4 for sequence 7.			
P860:5	0x403C:5	Sequence 7: Step 5			
0: Skip step (Reference: see P860:1)		Configuration of the step 5 for sequence 7.			
P860:6	0x403C:6	Sequence 7: Step 6			
0: Skip step (Reference: see P860:1)		Configuration of the step 6 for sequence 7.			
P860:7	0x403C:7	Sequence 7: Step 7			
0: Skip step (Reference: see P860:1)		Configuration of the step 7 for sequence 7.			
P860:8	0x403C:8	Sequence 7: Step 8			
0: Skip step (Reference: see P860:1)		Configuration of the step 8 for sequence 7.			
P860:9	0x403C:9	Sequence 7: Step 9			
0: Skip step (Reference: see P860:1)		Configuration of the step 9 for sequence 7.			
P860:10	0x403C:10	Sequence 7: Step 10			
0: Skip step (Reference: see P860:1)		Configuration of the step 10 for sequence 7.			
P860:11	0x403C:11	Sequence 7: Step 11			
0: Skip step (Reference: see P860:1)		Configuration of the step 11 for sequence 7.			
P860:12	0x403C:12	Sequence 7: Step 12			
0: Skip step (Reference: see P860:1)		Configuration of the step 12 for sequence 7.			
P860:13	0x403C:13	Sequence 7: Step 13			
0: Skip step (Reference: see P860:1)		Configuration of the step 13 for sequence 7.			
P860:14	0x403C:14	Sequence 7: Step 14			
0: Skip step (Reference: see P860:1)		Configuration of the step 14 for sequence 7.			
P860:15	0x403C:15	Sequence 7: Step 15			
0: Skip step (Reference: see P860:1)		Configuration of the step 15 for sequence 7.			
P860:16	0x403C:16	Sequence 7: Step 16			
0: Skip step (Reference: see P860:1)		Configuration of the step 16 for sequence 7.			
P861:0	0x403D	Number of cycles sequence 7			
1 ... [1] ... 65535		Definition of how often the sequence 7 is to be passed through. – 1 = one pass, 2 = two passes, ... – 65535 = infinite number of cycles.			

P865:1	0x403E:1	Sequence 8: Step 1			
0: Skip step 1: Segment 1 2: Segment 2 3: Segment 3 4: Segment 4 5: Segment 5 6: Segment 6 7: Segment 7 8: Segment 8		Configuration of the step 1 for sequence 8. – Alternatively to calling a single segment, a complete sequence (with a higher number) can also be called from one step. This, for instance, serves to configure a main sequence from which several subsequences are called successively. – With the setting "0", the respective step is skipped.			
P865:2	0x403E:2	Sequence 8: Step 2			
0: Skip step (Reference: see P865:1)		Configuration of the step 2 for sequence 8.			
P865:3	0x403E:3	Sequence 8: Step 3			
0: Skip step (Reference: see P865:1)		Configuration of the step 3 for sequence 8.			
P865:4	0x403E:4	Sequence 8: Step 4			
0: Skip step (Reference: see P865:1)		Configuration of the step 4 for sequence 8.			
P865:5	0x403E:5	Sequence 8: Step 5			
0: Skip step (Reference: see P865:1)		Configuration of the step 5 for sequence 8.			
P865:6	0x403E:6	Sequence 8: Step 6			
0: Skip step (Reference: see P865:1)		Configuration of the step 6 for sequence 8.			
P865:7	0x403E:7	Sequence 8: Step 7			
0: Skip step (Reference: see P865:1)		Configuration of the step 7 for sequence 8.			
P865:8	0x403E:8	Sequence 8: Step 8			
0: Skip step (Reference: see P865:1)		Configuration of the step 8 for sequence 8.			
P865:9	0x403E:9	Sequence 8: Step 9			
0: Skip step (Reference: see P865:1)		Configuration of the step 9 for sequence 8.			
P865:10	0x403E:10	Sequence 8: Step 10			
0: Skip step (Reference: see P865:1)		Configuration of the step 10 for sequence 8.			
P865:11	0x403E:11	Sequence 8: Step 11			
0: Skip step (Reference: see P865:1)		Configuration of the step 11 for sequence 8.			
P865:12	0x403E:12	Sequence 8: Step 12			
0: Skip step (Reference: see P865:1)		Configuration of the step 12 for sequence 8.			
P865:13	0x403E:13	Sequence 8: Step 13			
0: Skip step (Reference: see P865:1)		Configuration of the step 13 for sequence 8.			
P865:14	0x403E:14	Sequence 8: Step 14			
0: Skip step (Reference: see P865:1)		Configuration of the step 14 for sequence 8.			
P865:15	0x403E:15	Sequence 8: Step 15			
0: Skip step (Reference: see P865:1)		Configuration of the step 15 for sequence 8.			
P865:16	0x403E:16	Sequence 8: Step 16			
0: Skip step (Reference: see P865:1)		Configuration of the step 16 for sequence 8.			
P866:0	0x403F	Number of cycles sequence 8			
1 ... [1] ... 65535		Definition of how often the sequence 8 is to be passed through. – 1 = one pass, 2 = two passes, ... – 65535 = infinite number of cycles.			

5.10.3 Sequencer basic settings

In the presetting, the sequencer is disabled. In order to enable the sequencer, the desired sequencer mode (time and/or step operation) must be set. Moreover, different end of sequence modes and start of sequences modes are available.

Sequencer mode (P800:0)

- The sequencer can be operated in time and/or step operation.
- The following diagram demonstrates the different sequencer modes:

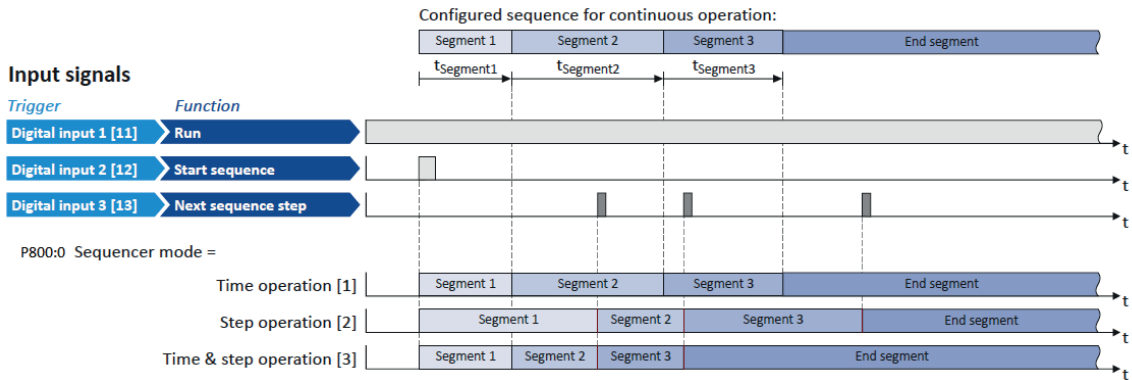

End of sequence mode (P824:0)

- The end of sequence mode defines the action after the end of the sequence.
- In the default setting "Keep running [0]", the setpoint set for the end segment is continuously transmitted to the motor control until the sequence is aborted.
- The following diagram demonstrates the different end of sequence modes:

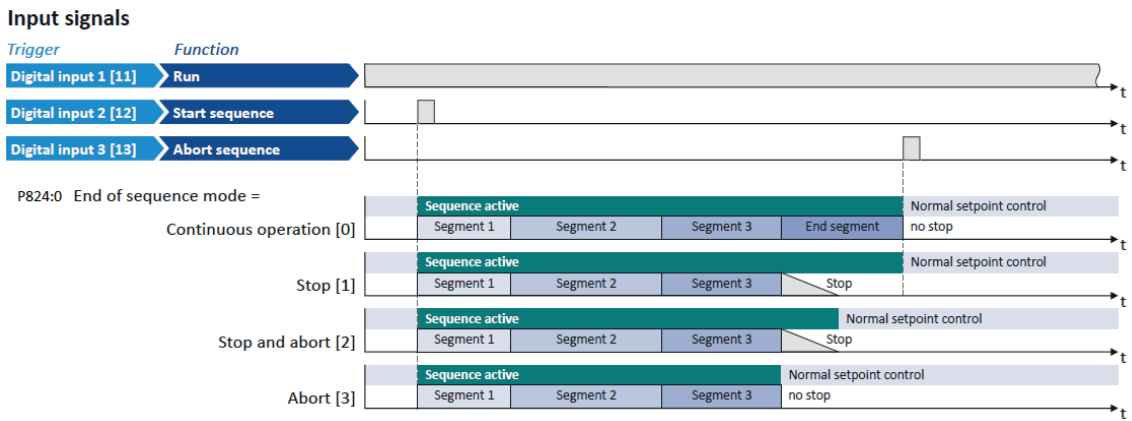

Start of sequence mode (P820:0)

- The start of sequence mode defines the action after the motor is stopped and restarted or after the motor has been restarted after an error occurred.
- In the default setting "Restart sequencer [0]", the currently selected sequence is restarted.
- The following diagram demonstrates the different start of sequence modes:

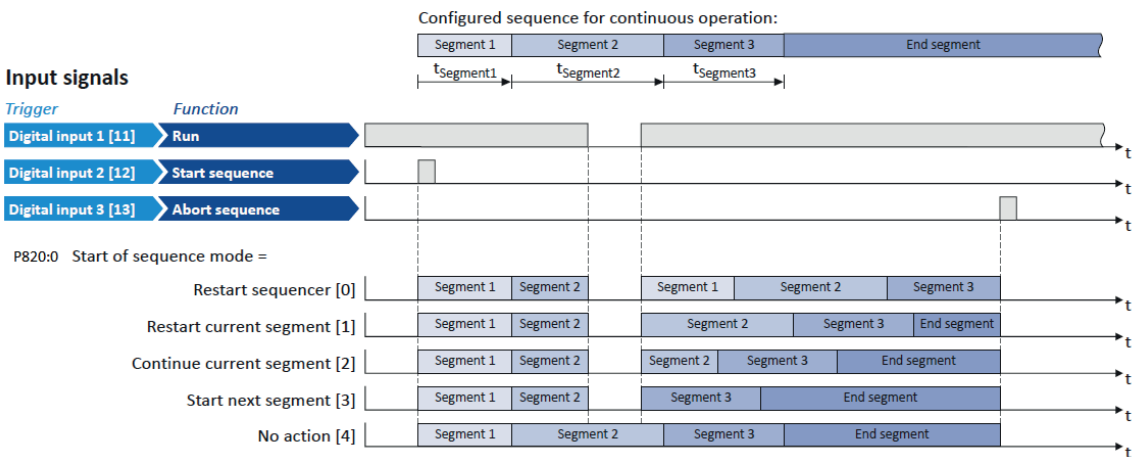

P800:0	0x4025	Sequencer mode			
0: Disabled 1: Time operation 2: Step operation 3: Time & step operation		Selection of the sequencer mode. 0: Disabled 1: Time operation The switch-over to the next step of the sequence is made after the time set for the current segment has elapsed. 2: Step operation The switch-over to the next step of the sequence is made via the trigger assigned in P400.32 to the "Next sequence step" function. 3: Time & step operation The switch-over to the next step of the sequence is made via the trigger assigned in P400.32 to the "Next sequence step" function, but no later than after the time set for the current segment has elapsed.			
P824:0	0x402F	End of sequence mode			
0: Keep running 1: Stop 2: Stop and abort 3: Abort		Selection of the action after the sequence has been completed, i. e., after the steps configured for the sequence have been passed through with the set numbers of cycles. 0: Keep running The setpoint set for the end segment is continuously transmitted to the motor control until the sequence is aborted. 1: Stop The motor is stopped with the stop method set in P203:3. The setpoint is continued to be controlled by the sequencer. In order to return to the normal setpoint control, the sequence must be aborted. Note! After returning to the normal setpoint control, a start command is required to restart the motor. 2: Stop and abort The motor is stopped with the stop method set in P203:3. After standstill is reached, it is automatically returned to the normal setpoint control. Note! After returning to the normal setpoint control, a start command is required to restart the motor. 3: Abort Return to the normal setpoint control without stopping the motor.			
P820:0	0x4040	Start of sequence mode			
0: Restart sequencer 1: Restart current segment 2: Continue current segment 3: Start next segment 4: No action		Selection of the action after the motor has been stopped and restarted or after the motor has been restarted after an error occurred. 0: Restart sequencer The currently selected sequence is restarted. 1: Restart current segment The current segment of the selected sequence is restarted. 2: Continue current segment The current segment of the selected sequence is continued (just like after a break). 3: Start next segment The next segment of the selected sequence is started. 4: No action For debugging purposes: The sequence is continued to be processed (including output states) even if the motor is stopped.			

5.10.4 Sequencer control functions

The following functions serve to control the sequencer.

Select sequence

A sequence is selected in a binary-coded fashion via the triggers assigned to the four functions "Select sequence (bit 0)" ... "Select sequence (bit 3)" in compliance with the following truth table:

Select sequence				Selection
Bit 3 P400:53	Bit 2 P400:52	Bit 1 P400:51	Bit 0 P400:50	
FALSE	FALSE	FALSE	FALSE	No sequence selected
FALSE	FALSE	FALSE	TRUE	Sequence 1
FALSE	FALSE	TRUE	FALSE	Sequence 2
FALSE	FALSE	TRUE	TRUE	Sequence 3
FALSE	TRUE	FALSE	FALSE	Sequence 4
FALSE	TRUE	FALSE	TRUE	Sequence 5
FALSE	TRUE	TRUE	FALSE	Sequence 6
FALSE	TRUE	TRUE	TRUE	Sequence 7
TRUE	FALSE	FALSE	FALSE	Sequence 8
TRUE	FALSE	FALSE	TRUE	Invalid selection
		...		
TRUE	TRUE	TRUE	TRUE	

Start sequence

The selected sequence is not started automatically. For starting the sequence, two functions are available:

- P400:30: Run/abort sequence (status-controlled start)
- P400:31: Start sequence (edge-controlled start)

Further control functions

The following functions serve to control the started sequence:

- P400:32: Next sequence step
- P400:33: Pause sequence
- P400:34: Suspend sequence
- P400:35: Stop sequence
- P400:36: Abort sequence

For controlling the sequencer via network, the sequencer control functions can also be assigned to the NetWordIN1 data word P590:1.

P400:30	0x2631:030	Run/abort sequence			
0: Not connected (Reference see P400:1)		Assignment of a trigger for the "Run/abort sequence" function. Trigger = TRUE: Start selected sequence. Trigger = FALSE: Abort sequence. Notes: - The assigned trigger must remain set to TRUE for the duration of the sequence. - If the trigger bit is reset to FALSE, the sequence is aborted. In this case, the standard setpoint or the setpoint source selected via setpoint change-over is active again. - A sequence is selected in a binary-coded fashion via the trigger assigned to the four functions "Select sequence (bit 0)" P400:50 ... "Select sequence (bit 3)" P400:53. - For an edge-controlled start, the function "Start sequence" P400:31 is optionally available.			
P400:31	0x2631:031	Start sequence			
0: Not connected (Reference see P400:1)		Assignment of a trigger for the "Start sequence" function. Trigger = FALSE→TRUE (edge): Start selected sequence. Trigger = TRUE→FALSE (edge): No action. Notes: - After the start, the sequencer remains activated until the function "Stop sequence" P400:35 or the function "Abort sequence" P400:36 is executed. A normal stop command does not reset the start command for the sequencer. - For a status-controlled start, the function "Run/abort sequence" P400:30 is optionally available.			
P400:32	0x2631:032	Next sequence step			
0: Not connected (Reference see P400:1)		Assignment of a trigger for the "Next sequence step" function. Trigger = FALSE→TRUE (edge): Next sequence step. Trigger = TRUE→FALSE (edge): No action. Notes: - The execution of the current step is completed even if the time parameterized for the segment has not elapsed yet. - The function is only relevant for Sequencer mode P800:0 = "Step operation [2]" or "Time & step operation [3]". - A jump to the next sequence step is not possible if the sequence pauses, the sequence is suspended or the final segment is executed.			
P400:33	0x2631:033	Pause sequence			
0: Not connected (Reference see P400:1)		Assignment of a trigger for the "Pause sequence" function. Trigger = TRUE: Pause sequence. Trigger = FALSE: Continue sequence. Notes: - During the pause, the sequence stops in the current step. The expiration of the time set for the segment is stopped. - The sequencer setpoint continues to remain active.			
P400:34	0x2631:034	Suspend sequence			
0: Not connected (Reference see P400:1)		Assignment of a trigger for the "Suspend sequence" function. Trigger = TRUE: Suspend sequence. Trigger = FALSE: Continue sequence. Notes: - This function serves to temporarily change over to the standard setpoint or the setpoint source selected via setpoint change-over. - The sequence is continued at the point where it was suspended.			
P400:35	0x2631:035	Stop sequence			
0: Not connected (Reference see P400:1)		Assignment of a trigger for the "Stop sequence" function. Trigger = FALSE→TRUE (edge): Stop sequence. Trigger = TRUE→FALSE (edge): No action. Notes: - If the sequence is stopped, it is jumped to the final segment. - The further execution depends on the selected End of sequence mode P824:0.			
P400:36	0x2631:036	Abort sequence			
0: Not connected (Reference see P400:1)		Assignment of a trigger for the "Abort sequence" function. Trigger = FALSE→TRUE (edge): Abort sequence. Trigger = TRUE→FALSE (edge): No action. Notes: - This function serves to directly stop the sequence without the final segment being executed. In this case, the standard setpoint or the setpoint source selected via setpoint change-over is active again.			
P400:50	0x2631:050	Select sequence (bit 0)			
0: Not connected (Reference see P400:1)		Assignment of a trigger for the "Select sequence (bit 0)" function. Selection bit with the valency 2 ⁰ for bit coded selection of a sequence. Trigger = FALSE: selection bit = "0". Trigger = TRUE: selection bit = "1". Notes: - The selected sequence is not started automatically. - For a status-controlled start, the function "Run/abort sequence" P400:30 is available. - For an edge-controlled start, the function "Start sequence" P400:31 is available.			

P400:51	0x2631:051	Select sequence (bit 1)			
0: Not connected (Reference see P400:1)		Assignment of a trigger for the "Select sequence (bit 1)" function. Selection bit with the valency 2 ¹ for the bit-coded selection of a sequence. Trigger = FALSE: selection bit = "0". Trigger = TRUE: selection bit = "1". Notes: – The selected sequence is not started automatically. – For a status-controlled start, the function "Run/abort sequence" P400:30 is available. – For an edge-controlled start, the function "Start sequence" P400:31 is available.			
P400:52	0x2631:052	Select sequence (bit 2)			
0: Not connected (Reference see P400:1)		Assignment of a trigger for the "Select sequence (bit 2)" function. Selection bit with the valency 2 ² for the bit-coded selection of a sequence. Trigger = FALSE: selection bit = "0". Trigger = TRUE: selection bit = "1". Notes: – The selected sequence is not started automatically. – For a status-controlled start, the function "Run/abort sequence" P400:30 is available. – For an edge-controlled start, the function "Start sequence" P400:31 is available.			
P400:53	0x2631:053	Select sequence (bit 3)			
0: Not connected (Reference see P400:1)		Assignment of a trigger for the "Select sequence (bit 3)" function. Selection bit with the valency 2 ³ for the bit-coded selection of a sequence. Trigger = FALSE: selection bit = "0". Trigger = TRUE: selection bit = "1". Notes: – The selected sequence is not started automatically. – For a status-controlled start, the function "Run/abort sequence" P400:30 is available. – For an edge-controlled start, the function "Start sequence" P400:31 is available.			

Example of operating mode

In the following example, the digital inputs 2 and 3 are used for controlling the sequencer.

- The analog input 1 is set as standard setpoint source.
- Switch S1 starts the motor in forward direction of rotation. Switch S1 in the initial position stops the motor again.
- Button S2 starts the sequence, button S3 aborts the sequence. After the abortion, the normal setpoint control is active again.

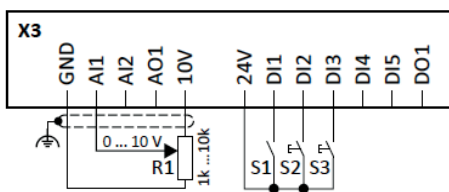

R1 = frequency setpoint selection
S1 = Run
S2 = Start sequence
S3 = Abort sequence

Parameter	Name	Setting for this example
P400:1	Enable VSD	Constant TRUE [1]
P400:2	Run	Digital input 1 [11]
P400:4	Reset fault	Not connected [0]
P400:13	Invert rotation	Not connected [0]
P400:31	Start sequence	Digital input 2 [12]
P400:36	Abort sequence	Digital input 3 [13]
P400:50	Select sequence (bit 0)	Constant TRUE [1]
P420:1	Relay	Sequencer controlled [100]
P420:2	Digital output 1	Sequencer controlled [100]
Segment and sequence configuration		
In this example, only the sequence 1 is used. The sequence consists of two steps (segment 1 and segment 2).		
P801:1	Sequencer segment 1: Frequency setpoint	40 Hz
P801:2	Sequencer segment 1: Acceleration/deceleration	20 s
P801:3	Sequencer segment 1: Time	18 s
P801:4	Sequencer segment 1: Digital outputs	0x00
P802:1	Sequencer segment 2: Frequency setpoint	30 Hz
P802:2	Sequencer segment 2: Acceleration/deceleration	15 s
P802:3	Sequencer segment 2: Time	14 s
P802:4	Sequencer segment 2: Digital outputs	0x02 (only relay)
P822:1	End segment: Frequency setpoint	10 Hz
P822:2	End segment: Acceleration/deceleration	8 s
P822:3	End segment: Time	10 s
P822:4	End segment: Digital outputs	0x04 (only digital output 1)
P830:1	Sequence 1: Step 1	Segment 1 [1]
P830:2	Sequence 1: Step 2	Segment 2 [2]
Sequencer basic settings		
P800:0	Sequencer mode	Time operation [1]
P824:0	End of sequence mode	Keep running [0]
P820:0	Start of sequence mode	Restart sequencer [0]

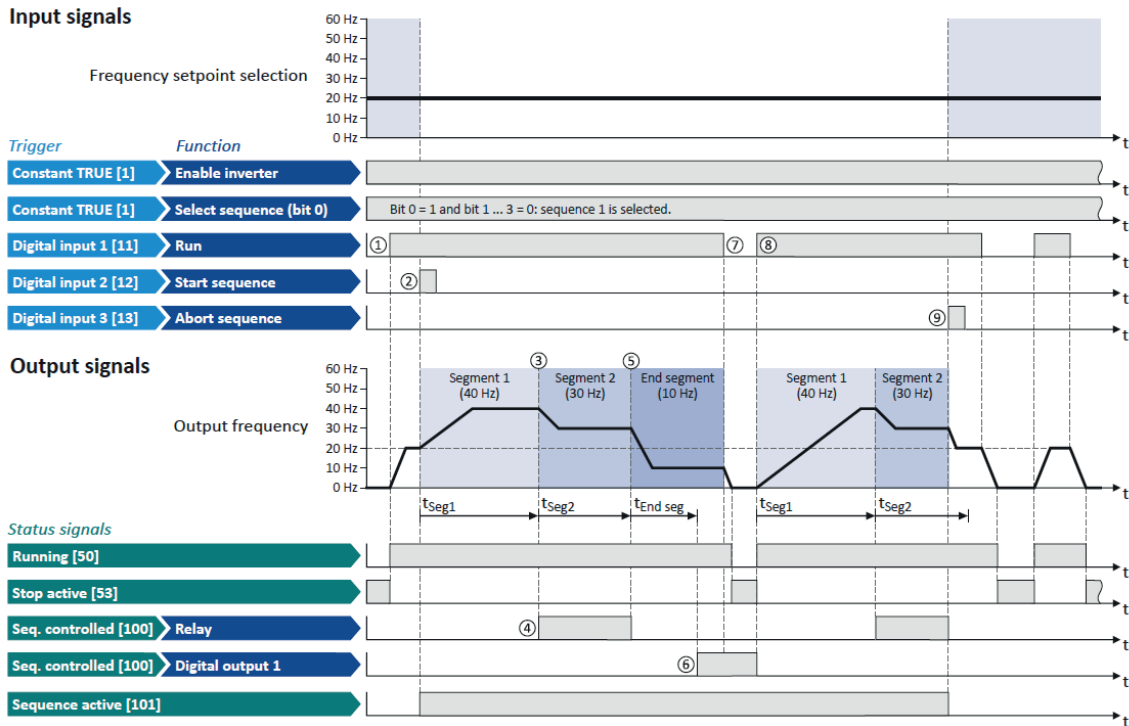













- ① If the VSD is enabled and no error is active, the motor can be started with the "Run" function. As the sequence has not been started yet, first the normal setpoint control is active.
- ② The "Start sequence" function is used to start the selected sequence in an edge-controlled way.
- ③ Sequencer mode P800:0 = "Time operation [1]":
The switch-over to the next step of the sequence is made after the time set for the current segment has elapsed.
- ④ The segment 2 is configured here in such a way that the relay will be triggered during the time of processing.
- ⑤ End of sequence mode P824:0 = "Keep running [0]":
After the sequence has been processed, the setpoint set for the end segment is continuously transmitted to the motor control until the sequence is aborted.
- ⑥ In case of the end segment, the time setting determines the delay after which the configured output states are to become active. Here, the end segment is configured in such a way that the digital output 1 is set after 10 s have expired.
- ⑦ If the "Run" function is set to FALSE, the motor is stopped with the stop method set in P203:3. The started sequence, however, remains active and the sequencer-controlled outputs keep their state.
- ⑧ Start of sequence mode P820:0 = "Restart sequencer [0]": If the "Run" function is set to TRUE again, the (still active) sequence is restarted.
- ⑨ The "Abort sequence" function is used to abort the sequence in an edge-controlled way. In this case, the standard setpoint or the setpoint source selected via setpoint change-over is active again.

6 TROUBLESHOOTING

6.1 LED STATUS DISPLAY

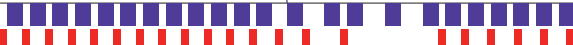
The "RDY" and "ERR" LED status displays on the front of the VSD provide some quick information about certain operating states.

"RDY" LED (blue)	"ERR" LED (red)	Status/meaning
off	off	No supply voltage.
 on	 on	Initialisation (VSD is started).
 blinking (1 Hz)	off	Safe torque off (STO) active.
	 blinking fast (4 Hz)	Safe torque off (STO) active, warning active.
 blinking (2 Hz)	off	VSD inhibited.
	 blinking fast (4 Hz)	VSD disabled, warning active.
	on	VSD disabled, error active.
	 lit every 1.5s for a short time	VSD inhibited, no DC-bus voltage.
	 on for a short time every 1s	USB module is connected, 5-V supply voltage for the USB module is available.
 on	off	VSD enabled. The motor rotates according to the specified setpoint or quick stop active.
	 blinking fast (4 Hz)	VSD enabled. The motor rotates according to the specified setpoint or quick stop active.
	 blinking (1 Hz)	VSD enabled, quick stop as response to fault active.
 Both LEDs are blinking in a rapidly alternating mode		Firmware update active.
 Both LEDs are blinking in a very rapidly synchronous mode		"Visual tracking" function is active.

6.2 ERROR HANDLING

Many functions integrated in the VSD can:

- detect errors and thus protect VSD and motor from damages,
- detect an operating error of the user,
- output a warning or information if desired.

6.2.1 Error types

In the event of an error, the VSD response is determined by the error type defined for the error. In the following, the different error types are described.

Error type "No response"

The error is completely ignored (does not affect the running process).

Error type "Warning"

A warning does not severely affect the process and may be also ignored in consideration of safety aspects.

Error type "Fault"

The motor is brought to a standstill with the quick stop ramp.

- The VSD will only be disabled after the quick stop is executed (motor at standstill) or after the time-out time set in 0x2826 has been elapsed.
- Exception: In case of a serious fault, the VSD is disabled immediately. The motor becomes torqueless (coasts). For details see the table "Error messages".

Error type "Trouble"

Just like "Fault", but the error state will be left automatically if the error condition is not active anymore.

- Exception: In case of a severe trouble, the VSD is disabled immediately. The motor becomes torqueless (coasts). For details see the table "Error messages".
- The restart behaviour after trouble can be configured.

i In the operating mode P301:0 = "Velocity mode [2]", the behavior in case of "Trouble" is just like in case of "Fault".

Comparison of the error types

The following table compares the main differences of the error types:

Error type	Logging in the Error history buffer / Logbook	Display in the CiA 402 status word 0x6041 (P780:0)	VSD disable	Motor stop	Error reset is required	"ERR" LED (red)
No response	No	No	No	No	No	off
Warning	Yes	Yes, bit 7	No	No	No	■■■■■■■■■■ blinking fast (4 Hz)
Trouble	Yes	Yes, bit 3	After quick stop or immediately. For details see table "Error messages"	Quick stop ramp or coasting.	No	■■■■ blinking (1 Hz)
Error	Yes	Yes, bit 3			Yes	■■■■■■■■■■ on

6.2.2 Error configuration

The errors can be divided into two types:

- Errors with predefined error type
- Errors with configurable error type



Especially critical errors are permanently set to the "Fault" error type in order to protect VSD and motor from damages.

In case of errors with configurable error type, the default setting can be changed in consideration of safety aspects and the operational performance. The selection "No response [0]" is, however, only available for minor errors.

The "Error messages" table lists the error type for each error. If the error type can be configured by the user, the "adjustable in" column displays the corresponding parameter.

6.2.3 Error reset

If the error condition is not active anymore, there are several options to reset an active error and thus leave the error state again:

- Via the keypad key .
- Via the trigger assigned to the "Reset fault" function.
- Via the button  in the software VLBXSW01.
- In the default setting of 0x400E:008 (P505:8) via bit 7 in the mappable data word NetWordIN1 0x4008:001 (P590:1).
- Via bit 7 in the mappable CiA 402 control word 0x6040.
- Via bit 2 in the mappable AC Drive control word 0x400B:001 (P592:1).
- Via bit 11 in the mappable Lovato control word 0x400B:002 (P592:2).

Notes:

- Certain errors can only be reset by mains switching.
- Certain errors (e. g. earth fault or short circuit of the motor phases) may cause a blocking time. In this case, the error can be reset only after the blocking time has elapsed. An active blocking time is displayed via bit 14 in the VSD status word 0x2831.

The "Error messages" table gives the blocking time (if available) for each error. This table also shows whether mains switching is required for the error reset.

6.2.4 Keypad error messages

If an error is pending, the keypad shows the following information:

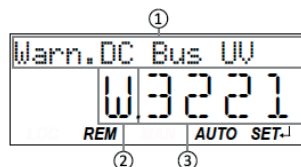

- ① Error text
- ② Error type: F=Fault, T=Trouble, W=Warning
- ③ Error code (hexadecimal)

Faults (F) and troubles (T) are displayed continuously.
Warnings (W) are only displayed every 2 seconds for a short time.

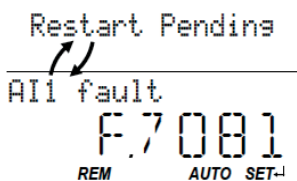

After a disturbance, a restart is possible if the error condition is not active anymore.
The keypad shows this by the "Restart Pending" note. The note is displayed in a 1-second interval alternating with the error text.

6.3 ERROR HISTORY

6.3.1 ERROR HISTORY KEYPAD

Any time the VSD experiences an Error condition during operation it is captured in the VSD non-volatile memory. For historical Error tracking purposes the Errors can be viewed in P155.00. This parameter contains the actual Error codes, the time (in running hours) that the Error occurred and the count of Errors (in case of multiple instances of the same Error condition). The Error History will retain the 32 most recent Errors.

The data in the Error History is described below:

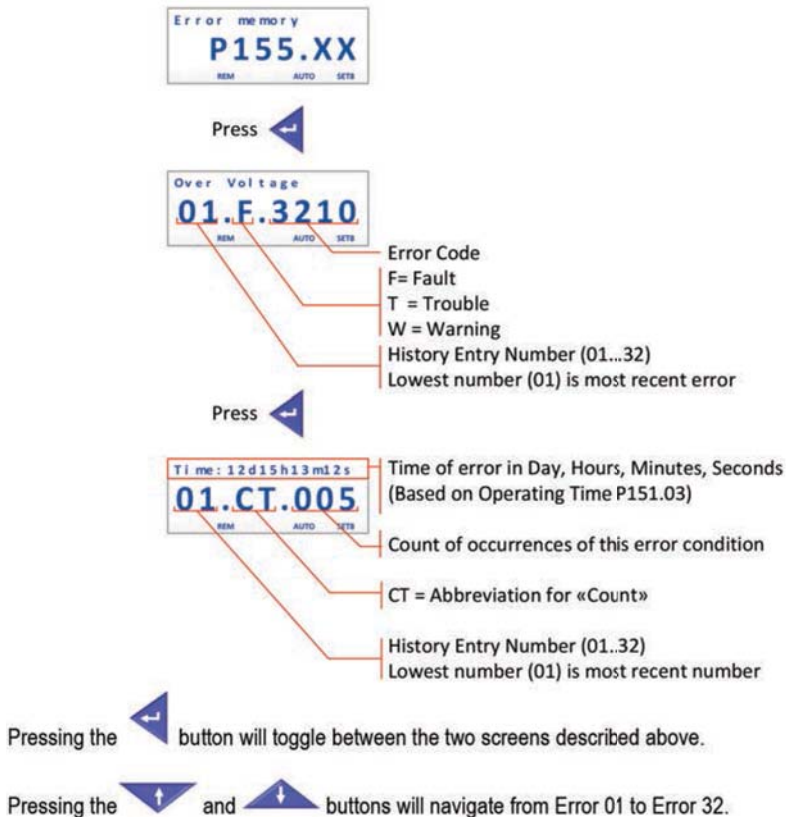

6.3.2 ERROR HISTORY VLBXSW01 SOFTWARE

	Opens the error logbook
	Reset the drive error

Time	Type	occurred in	CiA 402 error code	Text	Count
12:18:38:02	Error	Device	0x4310	motor temperature has reached error level	8
12:16:31:59	Error	Device	0xFF64	power stage communication is out of synchronization	1
12:16:31:55	Warning	Device	0xFF15	DC link circuit - undervoltage warning	0
12:16:31:55	Error	Device	0x3220	DC link circuit - undervoltage , 1V	1
12:16:31:55	Warning	Device	0xFF15	DC link circuit - undervoltage warning	1
12:15:02:09	Error	Device	0x4310	motor temperature has reached error level	10
12:14:30:25	Warning	Device	0xFF18	DC link circuit - overvoltage warning	1
12:14:26:35	Error	Device	0x4310	motor temperature has reached error level	1
12:14:26:20	Error	Device	0xFF64	power stage communication is out of synchronization	1
12:14:26:17	Error	Device	0x3220	DC link circuit - undervoltage , 1V	1
12:14:25:37	Error	Device	0x4310	motor temperature has reached error level	2
12:14:23:26	Error	Device	0xFF64	power stage communication is out of synchronization	1
12:14:23:23	Warning	Device	0xFF15	DC link circuit - undervoltage warning	0
12:14:23:23	Error	Device	0x3220	DC link circuit - undervoltage , 1V	1
12:14:23:22	Warning	Device	0xFF15	DC link circuit - undervoltage warning	1
12:05:56:20	Error	Device	0xFF53	connection list wrong connected (not safe manner)	2

Time	Time of the fault occurrence based on "Operation time (Control unit)" P150.03. If more than one fault of the same type is counted (Count >1) the first fault occurrence time is shown! [dd:hh:mm:ss]
Type	Error type (Warning, Error, Trouble)
Occurred in	Occurrence of the event
CiA 402 Error code	Error Code
Text	Error text
Count	Number of sequential fault occurrences

6.4 ERROR MESSAGES

The following table contains all error codes of the VSD in ascending order.

Cause	Error type/response	Remedy
8784 0x2250 CiA: Continuous over current (internal) Keypad display: PU over current		
<ul style="list-style-type: none"> - Continuous overcurrent on the VSD/ motor side. - Overcurrent at the brake chopper (brake transistor). - DC bus relay has not been closed due to a malfunction. 	Fault <ul style="list-style-type: none"> - The VSD is inhibited immediately. - The motor becomes torqueless (coasts). - The error can only be reset after a blocking time. 	<ul style="list-style-type: none"> - Check motor and wiring for short circuits. - Check brake resistor and wiring.
	Blocking time: 5 s	
8992 0x2320 CiA: Short circuit/earth leakage (internal) Keypad display: Earth leak		
<ul style="list-style-type: none"> - Short circuit/earth fault of motor cable - Capacitive charging current of the motor cable too high. 	Fault <ul style="list-style-type: none"> - The VSD is inhibited immediately. - The motor becomes torqueless (coasts). - The error can only be reset after a blocking time. 	<ul style="list-style-type: none"> - Check motor cable. - Check length of the motor cable. - Use shorter or lower-capacitance motor cable.
	Blocking time: 5 s	
9024 0x2340 CiA: Short circuit (device internal) Keypad display: Motor shorted		
Short circuit of motor cable	Fault <ul style="list-style-type: none"> - The VSD is inhibited immediately. - The motor becomes torqueless (coasts). - The error can only be reset after a blocking time. 	Check motor cable for short circuit.
	Blocking time: 5 s	
9040 0x2350 CiA: i^2t overload (thermal state) Keypad display: $i2t$ motor		
Motor thermally overloaded, e. g. by an impermissible continuous current or by frequent or too long acceleration processes.	Fault (Configurable) <ul style="list-style-type: none"> - The error can only be reset after a blocking time. 	<ul style="list-style-type: none"> - Check drive dimensioning. - Check machine/driven mechanics for excessive load.
	Blocking time: 5 s	
	Setting parameters: P308:3	
9090 0x2382 I^*t error Keypad display: Ixt error		
Device utilisation (I^*t) too high by frequent and too long acceleration processes.	Fault (Configurable) <ul style="list-style-type: none"> - The error can only be reset after a blocking time. 	Check drive dimensioning.
	Blocking time: 3 s	
	Setting parameters: P135:5	
9091 0x2383 I^*t warning Keypad display: Ixt warning		
Device utilisation (I^*t) too high by frequent and too long acceleration processes.	Warning	Check drive dimensioning.
9095 0x2387 I_{max} : Clamp responded too often Keypad display: Clamp timeout		
Maximum current of the axis (display in 0x2DDF:002) has been reached too often in succession.	Fault	<ul style="list-style-type: none"> - Select a flatter speed ramp. - Reduce the load. - Set I_{max} controller more dynamically.
9096 0x2388 SL-PSM stall detection active Keypad display: SL-PSM stall det.		
Overload of the motor with sensorless control for synchronous motors (SL-PSM).	Trouble <ul style="list-style-type: none"> - The VSD is inhibited immediately. - The motor becomes torqueless (coasts). 	<ul style="list-style-type: none"> - Reduce load at the axis. - Check settings of the SL-PSM parameters.
9098 0x238A Maximum current reached Keypad display: I_{max} reached		
The current motor current P103:0 is equal to or higher than the max. overload current P324:0.	Information	<ul style="list-style-type: none"> - Reduce the load on the motor or change the settings for the maximum overload current. P324:0.
12576 0x3120 Mains phase fault Keypad display: Mains Phase fail		
Mains phase failure	Fault	<ul style="list-style-type: none"> - Check wiring of the mains connection. - Check fuses.

12672 | 0x3180 UPS operation active

Keypad display: UPS oper. active

Cause	Error type/response	Remedy
Operation on uninterrupted 1x230V current supply (UPS) has been activated: Only a reduced output current is provided.	Warning	Switch back to operation with regular mains voltage.

12816 | 0x3210 DC bus overvoltage

Keypad display: DC Bus OV

Cause	Error type/response	Remedy
DC-bus voltage has exceeded the error threshold for overvoltage due to a too high braking energy or a too high mains voltage. The error threshold (display in P208:6) results from the setting of the rated mains voltage in P208:1.	Fault	<ul style="list-style-type: none"> – Reduce dynamic performance of the load profile. – Check mains voltage. – Check settings for brake energy management. – Connect brake resistor to the power unit and activate the integrated brake chopper.

12817 | 0x3211 DC bus overvoltage warning

Keypad display: Warn.DC Bus OV

Cause	Error type/response	Remedy
DC-bus voltage has exceeded the warning threshold for overvoltage set in P208:5 due to a too high braking energy or a too high mains voltage.	Warning	<ul style="list-style-type: none"> – Reduce dynamic performance of the load profile. – Check mains voltage. – Check settings for brake energy management. – Connect brake resistor to the power unit and activate the integrated brake chopper.

12832 | 0x3220 DC bus undervoltage

Keypad display: DC Bus UV

Cause	Error type/response	Remedy
DC-bus voltage has fallen below the error threshold for undervoltage. The error threshold (display in P208:3) results from the setting of the rated mains voltage in P208:1.	Trouble	<ul style="list-style-type: none"> – Check mains voltage. – Check DC-bus voltage. – Check mains settings.

12833 | 0x3221 DC bus undervoltage warning

Keypad display: Warn.DC Bus UV

Cause	Error type/response	Remedy
DC-bus voltage has fallen below the warning threshold for undervoltage set in P208:2.	Warning	<ul style="list-style-type: none"> – Check mains voltage. – Check DC-bus voltage. – Check mains settings.

12834 | 0x3222 DC-bus voltage too low for power up

Keypad display: DC-bus on-UV

Cause	Error type/response	Remedy
The input voltage is too low to switch on the VSD.	Warning	<ul style="list-style-type: none"> – Check mains voltage. – Check mains settings.

16912 | 0x4210 PU: overtemperature fault

Keypad display: PU Overtemp.

Cause	Error type/response	Remedy
The heatsink temperature of the power unit (display in P117:1) has exceeded the fixed error threshold (100 °C). <ul style="list-style-type: none"> – Ambient temperature too high. – Fan or ventilation slots are polluted. – Fan is defective. 	Fault	<ul style="list-style-type: none"> – Provide for a sufficient cooling of the device. – Clean fan and ventilation slots. – If required, replace fan.

17024 | 0x4280 Heat sink temperature sensor fault

Keypad display: Heatsink sensor

Cause	Error type/response	Remedy
Sensor for the temperature monitoring of the power unit is defective. The failure of the temperature monitoring function poses the risk of overheating!	Fault	Hardware error: it is necessary to contact the manufacturer, since the device must be replaced.

17025 | 0x4281 Heat sink fan warning

Keypad display: Heatsink fan

Cause	Error type/response	Remedy
Warning of the heatsink fan.	Warning	Check/replace the heatsink fan.

17029 | 0x4285 PU overtemperature warning

Keypad display: Warn.PU Overtemp

Cause	Error type/response	Remedy
The heatsink temperature of the power unit (display in P117:1) has exceeded the warning threshold set in 0x2D84:002. <ul style="list-style-type: none"> – Ambient temperature too high. – Fan or ventilation slots are polluted. – Fan is defective. 	Warning	<ul style="list-style-type: none"> – Provide for a sufficient cooling of the device. – Clean fan and ventilation slots. – If required, replace fan.

17168 0x4310 Motor temperature error		Keypad display: Overtemp. motor
Cause	Error type/response	Remedy
The motor temperature sensor connected to terminals X109/T1 and X109/T2 measures a too high motor temperature. – Motor too hot by impermissibly high currents. – Motor too hot by frequent and too long acceleration processes.	Fault (Configurable) – The error can only be reset after a blocking time.	– Check drive dimensioning. – Check motor temperature sensor and wiring.
	Blocking time: 5 s	
	Setting parameters: P309:2	

20754 0x5112 24 V supply critical		Keypad display: 24V supply low
Cause	Error type/response	Remedy
24V voltage failed or too low.	Warning	– Check optional external 24V voltage supply (terminal X3/24E), if connected. – Check mains voltage.

20864 0x5180 Overload 24 V supply		Keypad display: Overload 24V
Cause	Error type/response	Remedy
Output current at the 24V output or at the digital outputs too high.	Warning	Check 24V output and digital outputs for earth fault or overload.

21376 0x5380 OEM hardware incompatible		Keypad display: Incomp. OEM HW
Cause	Error type/response	Remedy
The control unit (OEM hardware) is not compatible with the power unit (OEM hardware).	Fault – The VSD is inhibited immediately. The motor becomes torqueless (coasts). – The error can only be reset by mains switching.	– Use compatible hardware. – Contact the OEM.

24970 0x618A Internal fan warning		Keypad display: Internal fan
Cause	Error type/response	Remedy
Warning of the internal fan.	Warning	Check/replace internal fan.

25216 0x6280 Trigger/functions connected incorrectly		Keypad display: P400 config err
Cause	Error type/response	Remedy
The assignment directives have not been observed. – If the "flexible I/O configuration" is active as control source, the "Enable VSD" or "Run" function must be connected to a digital input in order that the motor can be stopped again any time! – The use of the "Start forward (CW)" and "Start reverse (CCW)" functions excludes the use of the "Run forward (CW)" and "Run reverse (CCW)" functions, and vice versa.	Trouble	Check and correct the assignment of the triggers for the functions. – With keypad or network control, the two functions "Enable VSD" and "Run" can also be set to "Constant TRUE [1]" to start the motor.

25217 0x6281 User-defined fault 1		Keypad display: User fault 1
Cause	Error type/response	Remedy
Flexible I/O configuration: the "Activate fault 1" function was activated via the trigger selected in P400:43.	Fault	Eliminate error cause and then reset error.

25218 0x6282 User-defined fault 2		Keypad display: User fault 2
Cause	Error type/response	Remedy
Flexible I/O configuration: the "Activate fault 2" function was activated via the trigger selected in P400:44.	Fault	Eliminate error cause and then reset error.

25232 0x6290 Warning invert rotation		Keypad display: Invert rotation
Cause	Error type/response	Remedy
– Negative setpoint selection with an active limitation of rotation P304:0. – The "Reverse rotational direction" P400:13 function was requested with an active limitation of rotation P304:0.	Warning – The motor is brought to a standstill, since a reversal of the rotating direction is not permissible.	– Check setpoint selection and trigger. – Check setting in P304:0.

25233 0x6291 Maximum allowed troubles exceeded		Keypad display: Trouble overflow
Cause	Error type/response	Remedy
The number of permitted restart attempts after a fault set in P760:3 was exceeded. The fault occurred to frequently and could not be reset.	Fault – The motor remains at a standstill, no automatic restart is executed.	Check and eliminate the fault.

25248 0x62A0 User-defined fault		Keypad display: UserFault
Cause	Error type/response	Remedy
The "Activate fault" function was triggered via bit 10 of the control word P592:2.	Fault	Eliminate error cause and then reset error.
25249 0x62A1 Network: user fault 1		Keypad display: Netw.UserFault 1
Cause	Error type/response	Remedy
The "Activate fault 1" function was triggered via the NetWordIN1 data word P590:1.	Fault	Eliminate error cause and then reset error.
25250 0x62A2 Network: user fault 2		Keypad display: Netw.UserFault 2
Cause	Error type/response	Remedy
The "Activate fault 2" function was triggered via the NetWordIN1 data word P590:1.	Fault	Eliminate error cause and then reset error.
25265 0x62B1 NetWordIN1 configuration incorrect		Keypad display: NetWordIN1 error
Cause	Error type/response	Remedy
Two bits of the NetWordIN1 data word P590:1 were assigned to the same function.	Trouble	Check and correct configuration of the NetWordIN1 data word. – The functions that are to be triggered via bits 0 ... 15 of the NetWordIN1 data word are defined in P505:1 ... P505:16.
25505 0x63A1 CU: load error ID tag		Keypad display: CU ID tag error
Cause	Error type/response	Remedy
Calibration data of the control unit not compatible or faulty.	Trouble – The VSD is inhibited immediately. The motor becomes torqueless (coasts). – The error can only be reset by mains switching.	– Update firmware of the VSD to the most recent version. – If the error persists, the control unit or the device has to be replaced. In this case, please contact the manufacturer.
25506 0x63A2 PU: load error ID tag		Keypad display: PU ID tag error
Cause	Error type/response	Remedy
Calibration data of the power unit not compatible or faulty.	Trouble – The VSD is inhibited immediately. The motor becomes torqueless (coasts). – The error can only be reset by mains switching.	Update firmware of the VSD to the most recent version. – If the error persists, the power unit or the device has to be replaced. In this case, please contact the manufacturer.
25507 0x63A3 Power unit unknown		Keypad display: PU unknown
Cause	Error type/response	Remedy
The power unit installed is not supported by the software.	Trouble – The VSD is inhibited immediately. The motor becomes torqueless (coasts). – The error can only be reset by mains switching.	Update firmware of the VSD to the most recent version.
28800 0x7080 Assertion level monitoring (Low/High)		Keypad display: Assertionlevel
Cause	Error type/response	Remedy
The last setting of the connection level differs from the saved setting.	Fault	1. Check setting in P410:1. 2. Execute device command "Save user data" P700:3. 3. Switch VSD off and on again.
28801 0x7081 Analog input 1 fault		Keypad display: AI1 fault
Cause	Error type/response	Remedy
The monitoring function of the input signal configured for analog input 1 in P430:8 and P430:9 has been triggered.	Fault (Configurable)	– Check input signal at analog input 1. – Check configuration of the monitoring function.
	Setting parameters: P430:10	
28802 0x7082 Analog input 2 fault		Keypad display: AI2 fault
Cause	Error type/response	Remedy
The monitoring function of the input signal configured for analog input 2 in P431:8 and P431:9 has been triggered.	Fault (Configurable)	– Check input signal at analog input 2. – Check configuration of the monitoring function.
	Setting parameters: P431:10	
28803 0x7083 HTL input fault		Keypad display: HTL input fault
Cause	Error type/response	Remedy
The monitoring of the input signal configured for the HTL input has been triggered.	No response (Configurable)	– Check input signal at the HTL input. – Check configuration of the monitoring function.
	Setting parameters: P416:6	

28833 0x70A1 Analog output 1 fault		Keypad display: AO1 fault
Cause	Error type/response	Remedy
Open circuit or short circuit at analog output 1.	Warning	<ul style="list-style-type: none"> – Check wiring of analog output 1. – Check definition of the output range in P440:1.
28834 0x70A2 Analog output 2 fault		Keypad display: AO2 fault
Cause	Error type/response	Remedy
Open circuit or short circuit at analog output 2.	Warning	<ul style="list-style-type: none"> – Check wiring of analog output 2. – Check definition of the output range in P441:1.
28961 0x7121 Pole position identification fault		Keypad display: Pole pos. error
Cause	Error type/response	Remedy
<ul style="list-style-type: none"> – Too many deviations during the pole position identification. – Compared to the VSD, the rated motor current is too high or too low. 	Fault (Configurable)	<ul style="list-style-type: none"> – Check setting of the motor data. – Ensure that the motor is at a standstill during the pole position identification process. – Ensure that the motor and VSD match each other in terms of power.
	Setting parameters: 0x2C60	
29056 0x7180 Motor overcurrent		Keypad display: Mot max current
Cause	Error type/response	Remedy
The motor current has exceeded the warning/ error threshold for the motor current monitoring set in P353:1.	Fault (Configurable)	<ul style="list-style-type: none"> – Check motor load. – Check drive dimensioning. – Check warning threshold or error threshold set in P353:1.
	– The error can only be reset after a blocking time.	
	Blocking time: 1 s	
	Setting parameters: P353:2	
29445 0x7305 Encoder open circuit		Keypad display: Encoder error
Cause	Error type/response	Remedy
The encoder signal loss monitoring function has detected a failure of the encoder signal.	Fault (Configurable)	<ul style="list-style-type: none"> – Check the encoder connection. – Check encoder cable for wire breakage. – Check encoder current supply.
	Setting parameters: P342:0	
29573 0x7385 Feedback system: speed limit		Keypad display: F.fdb spd limit
Cause	Error type/response	Remedy
The feedback system exceeds the maximum permissible frequency range of the digital inputs.	Warning	Check feedback system.
30336 0x7680 Memory module is full		Keypad display: EPM full
Cause	Error type/response	Remedy
The memory module contains too many parameter settings.	Warning <ul style="list-style-type: none"> – The parameter settings were not saved in the memory module 	Execute "Save user data" P700:3 device command again. This reinitialises the user memory with the current parameter settings. In this way, parameter settings that are no longer required are automatically deleted.
30337 0x7681 Memory module not present		Keypad display: EPM not present
Cause	Error type/response	Remedy
The VSD memory module was removed.	Fault <ul style="list-style-type: none"> – The default setting stored in the VSD firmware has been loaded. – The error cannot be reset by the user. 	<ol style="list-style-type: none"> 1. Switch off VSD. 2. Plug the memory module into the VSD. 3. Switch the VSD on again. <p>Note: The memory module cannot be replaced during ongoing operation!</p>
30338 0x7682 Memory module: Invalid user data		Keypad display: EPM invalid data
Cause	Error type/response	Remedy
The user parameter settings in the memory module are invalid.	Fault <ul style="list-style-type: none"> – The user parameter settings are lost. – The default settings were automatically loaded. 	<ol style="list-style-type: none"> 1. Execute user parameter settings again. 2. Execute device command "Save user data" P700:3.

30340 0x7684 Data not compl. saved before powerdown		Keypad display: Save incomplete
Cause	Error type/response	Remedy
Saving of the parameter settings was interrupted by an unexpected disconnection.	Warning <ul style="list-style-type: none"> – The user parameter settings were not fully saved. been loaded. – At the next switch-on, the data stored are copied to the user memory. 	<ol style="list-style-type: none"> 1. Check user parameter settings. (The loaded backup is an older version.) 2. If required, repeat the changes made last. 3. Execute device command "Save user data" P700:3.

30342 0x7686 Internal communication error		Keypad display: Int. Comm.Err.
Cause	Error type/response	Remedy
Communication between the power unit and the control unit is faulty.	Fault	<ol style="list-style-type: none"> 1. Switch off VSD. 2. Install control unit correctly on power unit. 3. Switch the VSD on again.

30345 0x7689 Memory module: invalid OEM data		Keypad display: OEM data invalid
Cause	Error type/response	Remedy
The OEM memory contains invalid parameter settings or is empty.	Warning <ul style="list-style-type: none"> – The user parameter settings were automatically loaded. 	<ul style="list-style-type: none"> – Execute device command "Save OEM data" P700:6. – Thus, the user parameter settings get lost!

30346 0x768A Memory module: wrong type		Keypad display: Wrong EPM
Cause	Error type/response	Remedy
The memory module connected is not supported by the VSD.	Fault <ul style="list-style-type: none"> – The default setting stored in the VSD firmware has been loaded. – The error cannot be reset by the user. 	<ol style="list-style-type: none"> 1. Switch off VSD. 2. Replace plugged-in memory module by a memory module that matches the VSD. 3. Switch the VSD on again.

30352 0x7690 EPM firmware version incompatible		Keypad display: EPM-FW incomp.
Cause	Error type/response	Remedy
The parameter settings saved in the memory module are incompatible with the firmware version.	Fault <ul style="list-style-type: none"> – The data have been loaded into the RAM memory, but they are incompatible. 	<ol style="list-style-type: none"> 1. Execute device command "Load default settings" P700:1. 2. Execute "Save user data" P700:3 or "Save OEM data" P700:6 device command.

30353 0x7691 EPM data: firmware type incompatible		Keypad display: EPM: FW incomp.
Cause	Error type/response	Remedy
The parameter settings saved in the memory module are incompatible with the firmware type. Example: Memory module of an VSD with an application IO is used in an VSD with a standard IO.	Fault <ul style="list-style-type: none"> – The data have been loaded into the RAM memory, but they are incompatible. 	<ol style="list-style-type: none"> 1. Execute device command "Load default settings" P700:1. 2. Execute "Save user data" P700:3 or "Save OEM data" P700:6 device command.

30354 0x7692 EPM data: new firmware type detected		Keypad display: UserCU not match
Cause	Error type/response	Remedy
The parameter settings saved in the memory module do not match the VSD hardware.	Fault <ul style="list-style-type: none"> – The data have been loaded into the RAM memory without being modified, and they are compatible. – The settings loaded must be accepted by the user (see remedy). 	<ol style="list-style-type: none"> 1. Check parameter settings. 2. Reset error. 3. Execute "Save user data" P700:3 or "Save OEM data" P700:6 device command.

30355 0x7693 EPM data: PU size incompatible		Keypad display: EPM PU size inco
Cause	Error type/response	Remedy
The parameter settings saved in the memory module are incompatible with the VSD.	Fault <ul style="list-style-type: none"> – The data have been loaded into the RAM memory, but they are incompatible. 	<ol style="list-style-type: none"> 1. Execute device command "Load default settings" P700:1. 2. Execute "Save user data" P700:3 or "Save OEM data" P700:6 device command.

30356 0x7694 EPM data: new PU size detected		Keypad display: EPM new PU size
Cause	Error type/response	Remedy
The parameter settings saved in the memory module comply with a different hardware. Example: Memory module of an VSD with a power of 3 kW is used in an VSD with a power of 18.5 kW.	Fault <ul style="list-style-type: none"> – The data have been loaded into the RAM memory without being modified, and they are compatible. – The settings loaded must be accepted by the user (see remedy). 	<ol style="list-style-type: none"> 1. Check parameter settings. 2. Reset error. 3. Execute "Save user data" P700:3 or "Save OEM data" P700:6 device command.

30357 0x7695 Invalid parameter changeover configuration		Keypad display: InvalidChgovrCfg
Cause	Error type/response	Remedy
One or more parameters can no longer be used for the "Parameter change-over" function.	Warning – The parameter change-over function is deactivated.	1. Check error message for parameter change-over in P756:1. 2. Correct the list entry shown in P756:2.
30358 0x7696 EPM data: unknown parameter found		Keypad display: Unkn. Par in EPM
Cause	Error type/response	Remedy
The memory module contains parameter settings for one or several parameters that are not known to the VSD.	Information	Execute the "Save user data" P700:3 device command. This reinitialises the user memory with the current parameter settings. In this way, parameter settings that are no longer required are automatically deleted.
30359 0x7697 Parameter changes lost		Keypad display: Parameter loss
Cause	Error type/response	Remedy
A voltage failure has occurred and changed parameter settings that had not been saved yet were available.	Fault – The parameter settings changed have been lost.	1. Execute parameter settings again. 2. Execute device command "Save user data" P700:3.
33042 0x8112 Network: timeout explicit message		Keypad display: TO expl. ms
Cause	Error type/response	Remedy
– Within the time-out period for explicit messages, which has been parameterised by the scanner, no "explicit message" was received. – The connection to the scanner has been interrupted. – Failure of an explicit connection.	Warning (Configurable) Setting parameters: P515:6.	– Check cables and terminals. – Plug network cables into the Ethernet port. – Check the requested package interval (RPI) of the explicit connection. – Increase time limit for explicit messages in the scanner.
33154 0x8182 CAN: bus off		Keypad display: CAN bus off
Cause	Error type/response	Remedy
Too many faulty frames have been received. – Defective cable (e. g. loose contact). – Two nodes with the same node address.	Trouble (Configurable) – Change to the "Bus-Off" communication status. Setting parameters: 0x2857:010	– Check wiring of the network. – Check bus terminating resistor. – Set the identical baud rate for each node of the network. – Assign a unique node address to each node of the network. – Eliminate EMC interferences.
33155 0x8183 CAN: warning		Keypad display: CAN bus warning
Cause	Error type/response	Remedy
Too many faulty frames have been received. – Defective cable (e. g. loose contact). – Two nodes with the same node address.	Warning (Configurable) Setting parameters: 0x2857:011	– Check wiring of the network. – Check bus terminating resistor. – Set the identical baud rate for each node of the network. – Assign a unique node address to each node of the network. – Eliminate EMC interferences.
33156 0x8184 CAN: heartbeat time-out consumer 1		Keypad display: CAN heartb. C1
Cause	Error type/response	Remedy
Within the heartbeat time P520:1, no heartbeat telegram was received by node 1 to be monitored.	Fault (Configurable) Setting parameters: 0x2857:005	– Check communication with the heartbeat producer. – Reactivate heartbeat producer.
33157 0x8185 CAN: heartbeat time-out consumer 2		Keypad display: CAN heartb. C2
Cause	Error type/response	Remedy
Within the heartbeat time P520:2, no heartbeat telegram was received by node 2 to be monitored.	Fault (Configurable) Setting parameters: 0x2857:006	– Check communication with the heartbeat producer. – Reactivate heartbeat producer.
33158 0x8186 CAN: heartbeat time-out consumer 3		Keypad display: CAN heartb. C3
Cause	Error type/response	Remedy
Within the heartbeat time P520:3, no heartbeat telegram was received by node 3 to be monitored.	Fault (Configurable) Setting parameters: 0x2857:007	– Check communication with the heartbeat producer. – Reactivate heartbeat producer.
33159 0x8187 CAN: heartbeat time-out consumer 4		Keypad display: CAN heartb. C4
Cause	Error type/response	Remedy
Within the heartbeat time P520:4, no heartbeat telegram was received by node 4 to be monitored.	Fault (Configurable) Setting parameters: 0x2857:008	– Check communication with the heartbeat producer. – Reactivate heartbeat producer.

33168 0x8190 Network: watchdog timeout		Keypad display: Watchdog timeout
Cause	Error type/response	Remedy
Time-out during cyclic data reception, e.g. due to an interrupted communication link to the master or missing cyclic data.	Trouble (Configurable)	<ul style="list-style-type: none"> • Check wiring of the network. • Eliminate EMC interferences.
	Setting parameters: P515:1 (PROFIBUS, EtherCAT, PROFINET)	
33169 0x8191 Network: disruption of cyclic data exchange		Keypad display: Cycl data error
Cause	Error type/response	Remedy
The communication partner has interrupted the cyclic data exchange.	No response (Configurable)	<ul style="list-style-type: none"> – Check wiring of the network. – The slave must receive new parameterisation and configuration files by the master, in order to be able to exchange data again.
	Setting parameters: P515:2	
33170 0x8192 Network: initialisation error		Keypad display: Net. Init. error
Cause	Error type/response	Remedy
The initialisation of the communication stack has been interrupted due to an incorrect address setting or communication configuration.	Trouble (Configurable)	Check master/slave configuration and restart the devices.
	Setting parameters: 515:4 (PROFIBUS, EtherCAT, PROFINET)	
33171 0x8193 Network: invalid cyclic process data		Keypad display: Inv. cyclic data
Cause	Error type/response	Remedy
The cyclic process data received are invalid.	Trouble (Configurable)	Check cyclic process data sent by the master.
	Setting parameters: 515:5 (PROFIBUS, EtherCAT, PROFINET)	
33185 0x81A1 Modbus: network time-out		Keypad display: Modbus time-out
Cause	Error type/response	Remedy
No valid messages have been received via the Modbus for a longer time than the time-out time set in P515:2.	Fault (Configurable)	<ul style="list-style-type: none"> – Check communication with the master. – Check wiring. – Check bus termination.
	Setting parameters: P515:1	
33186 0x81A2 Modbus: incorrect request by master		Keypad display: Modbus request
Cause	Error type/response	Remedy
The request by the master is invalid, e. g. invalid CRC checksum, non-supported function code, or impermissible data access.	Warning	Check request by the master: <ul style="list-style-type: none"> – Value in the valid range? – Function code valid? – No impermissible write access? (e. g. with regard to read-only parameters)
	<ul style="list-style-type: none"> – The VSD (slave) responds to the master with an error code: 0x01 = invalid function code 0x02 = invalid data address 0x03 = invalid data value 0x04 = slave device failure 	
33200 0x81B0 Network communication faulty		Keypad display: Comm. faulty
Cause	Error type/response	Remedy
In case of the Ethernet communication interface, an internal software error has occurred.	Trouble	<ul style="list-style-type: none"> – Switch VSD off and on again. – In the event of a power failure during a firmware download, it is required to reload the firmware via the USB module and then restart the VSD.
33414 0x8286 Network: PDO mapping error		Keypad display: PDO map error
Cause	Error type/response	Remedy
<ul style="list-style-type: none"> – Invalid PDO assignment by the master. – Internal PDO assignment was changed and does not comply with the configuration available in the master. 	Trouble (Configurable)	Check data mapping in the master and slave.
	Setting parameters: P515:3 (PROFIBUS, EtherCAT, PROFINET)	
33425 0x8291 CAN: RPDO1 time-out		Keypad display: Timeout RPDO1
Cause	Error type/response	Remedy
RPDO1 was not received within the time-out period set in P540:5 or with the sync configured.	Fault (Configurable)	<ul style="list-style-type: none"> – Eliminate EMC interferences. – Check bus load.
	Setting parameters: 0x2857:001	

33426 0x8292 CAN: RPDO2 time-out		Keypad display: Timeout RPDO2
Cause	Error type/response	Remedy
RPDO2 was not received within the time-out period set in P541:5 or with the sync configured.	Fault (Configurable)	<ul style="list-style-type: none"> – Eliminate EMC interferences. – Check bus load.
	Setting parameters: 0x2857:002	
33427 0x8293 CAN: RPDO3 time-out		Keypad display: Timeout RPDO3
Cause	Error type/response	Remedy
RPDO3 was not received within the time-out period set in P542:5 or with the sync configured.	Fault (Configurable)	<ul style="list-style-type: none"> – Eliminate EMC interferences. – Check bus load.
	Setting parameters: 0x2857:003	
33553 0x8311 Torque limit reached		Keypad display: Torque limit
Cause	Error type/response	Remedy
Motor has reached the torque limit: <ul style="list-style-type: none"> – P337:3: Actual positive torque limit – P337:4: Actual negative torque limit 	No response (Configurable)	<ul style="list-style-type: none"> – Observe load requirements. – Reduce motor load. – Check set torque limits and sources for the torque limits.
	Setting parameters: P329:1	
33664 0x8380 Function not allowed in selected operating mode		Keypad display: Func. n. allowed
Cause	Error type/response	Remedy
The selected function is not permissible in the chosen operating mode. <ul style="list-style-type: none"> – Selection of torque mode [-1] in P301:0 with incompatible motor control in P300:0. – Selection of invalid drive mode [0] in P301:0. 	Warning	<ul style="list-style-type: none"> – Note: selection of torque mode [-1] in P301:0 with incompatible motor control in P300:0. – Check settings of operation modes.
36992 0x9080 Keypad removed		Keypad display: Keypad removed
Cause	Error type/response	Remedy
The keypad was removed while the keypad control was activated.	Fault	<ul style="list-style-type: none"> – Plug keypad back in or activate another control source.
65282 0xFF02 Brake resistor: overload fault		Keypad display: BrkResistor OL.F
Cause	Error type/response	Remedy
The calculated thermal load of the brake resistor has reached the error threshold set in P707:9. The regenerative energy is too high.	Fault (Configurable)	<ul style="list-style-type: none"> – Check drive dimensioning. – Check settings for the brake energy management. Note: The error status will be reset if the thermal load falls below the error threshold - 20 %.
	– The error can only be reset after a blocking time.	
	Blocking time: 5 s	
	Setting parameters: P707:11	
65285 0xFF05 Safe Torque Off is locked		Keypad display: STO locked
Cause	Error type/response	Remedy
The safety module or safety circuit of the device was detected as being defective.	Fault <ul style="list-style-type: none"> – The VSD is inhibited immediately. The motor becomes torqueless (coasts). – The error can only be reset by mains switching. 	Hardware error: it is necessary to contact the manufacturer since the device must be replaced.
65286 0xFF06 Motor overspeed		Keypad display: Motor overspeed
Cause	Error type/response	Remedy
The motor speed has reached the error threshold for overspeed set in P35:1.	Fault (Configurable)	Check application.
	– The error can only be reset after a blocking time.	
	Blocking time: 1 s	
	Setting parameters: P350:2	
65289 0xFF09 Motor phase missing		Keypad display: Mot.Phase miss.
Cause	Error type/response	Remedy
A failure of several motor phases has been detected.	No response (Configurable)	<ul style="list-style-type: none"> • Check wiring between VSD and motor. • In case of a false tripping, adapt the settings for the motor phase failure detection.
	– The error can only be reset after a blocking time.	
	Blocking time: 2 s	
	Setting parameters: P310:1	

65290 0xFF0A Motor phase failure phase U		Keypad display: Phase U failure
Cause	Error type/response	Remedy
A failure of the motor phase U has been detected.	No response (Configurable) – The error can only be reset after a blocking time.	<ul style="list-style-type: none"> • Check wiring between VSD and motor. • In case of a false tripping, adapt the settings for the motor phase failure detection.
	Blocking time: 2 s	
	Setting parameters: P310:1	

65291 0xFF0B Motor phase failure phase V		Keypad display: Phase V failure
Cause	Error type/response	Remedy
A failure of the motor phase V has been detected.	No response (Configurable) – The error can only be reset after a blocking time.	<ul style="list-style-type: none"> • Check wiring between VSD and motor. • In case of a false tripping, adapt the settings for the motor phase failure detection.
	Blocking time: 2 s	
	Setting parameters: P310:1	

65292 0xFF0C Motor phase failure phase W		Keypad display: Phase W failure
Cause	Error type/response	Remedy
A failure of the motor phase W has been detected.	No response (Configurable) – The error can only be reset after a blocking time.	<ul style="list-style-type: none"> • Check wiring between VSD and motor. • In case of a false tripping, adapt the settings for the motor phase failure detection.
	Blocking time: 2 s	
	Setting parameters: P310:1	

65305 0xFF19 Motor parameter identification fault		Keypad display: Motor ID fault
Cause	Error type/response	Remedy
During the automatic identification of the motor, an error has occurred.	Fault	<ul style="list-style-type: none"> – Set motor data so that they comply with the data on the motor nameplate. – Check wiring of the motor.

65311 0xFF1F FMF Error		Keypad display: FMF Error
Cause	Error type/response	Remedy
Configuration or runtime error	Fault	<ul style="list-style-type: none"> – Check configuration – Check FMF error code 0x4050:002 to determine the error cause.

65334 0xFF36 Brake resistor: overload warning		Keypad display: BrkResistor OL.W
Cause	Error type/response	Remedy
The calculated thermal load of the brake resistor has reached the warning threshold set in P707:8. The regenerative energy is too high.	Warning (Configurable)	<ul style="list-style-type: none"> • Check drive dimensioning. • Check settings for the brake energy management. Note: The warning status is reset if the thermal load falls below the warning threshold of -20%.
	Setting parameters: P707:10	

65335 0xFF37 Automatic start disabled		Keypad display: Auto start disab
Cause	Error type/response	Remedy
At mains connection, a start command was already available and the automatic start at power-up is set in P203:2 to "Off [0]".	Fault	Deactivate starting command and reset error.

65336 0xFF38 Load loss detected		Keypad display: Load loss
Cause	Error type/response	Remedy
In a running motor, the motor load (current) is monitored. When the motor load falls below the threshold value specified in Load loss detection: threshold P710:1 for the period of time specified in Load loss detection: delay time (P710:2), load loss protection is triggered.	No response (Configurable)	Check utilisation
	Setting parameters: P710:3	

65337 0xFF39 Motor overload		Keypad display: Motor overload
Cause	Error type/response	Remedy
If the apparent motor current exceeds a defined threshold value 0x4007:002 for a certain amount of time 0x4007:001, heavy duty monitoring is triggered.	No response (Configurable)	Check the motor load.
	Setting parameters: 0x4007:003	

65366 0xFF56 Maximum motor frequency reached		Keypad display: Max. motor freq.
Cause	Error type/response	Remedy
<ul style="list-style-type: none"> - The maximum motor speed set in P322:0 is active. - The maximum output frequency of the VSD has been reached. 	Warning	Check application.

65393 0xFF71 Wrong password		Keypad display: Wrong password
Cause	Error type/response	Remedy
A wrong password has been entered several times.	Warning <ul style="list-style-type: none"> - The blocking time for entering a password is more than 10 seconds. (The blocking time is doubled every time an incorrect password is entered.) - No password can be entered as long as the blocking time is active. 	Wait until the blocking time has elapsed and then enter the correct password.

65394 0xFF72 Warning		Keypad display: Warning
Cause	Error type/response	Remedy
VSD is not compatible with the Controller/PLC (brand protection). <ul style="list-style-type: none"> - The Controller has not written a deactivation password in the parameter yet. - The deactivation password written by the Controller is incorrect. 	Warning <ul style="list-style-type: none"> • No response from the VSD. • The decision on whether the machine will be commissioned or not is made by the Controller. 	Use corresponding (compatible) OEM components.

65395 0xFF73 Fatal Error		Keypad display: Fatal Error
Cause	Error type/response	Remedy
Error when reading the data from the control unit.	Fault <ul style="list-style-type: none"> - Operation of the VSD is not possible. 	<ul style="list-style-type: none"> - Switch VSD off and on again. - If the error occurs again, the manufacturer must be contacted, since the control unit or the device has to be replaced.

65396 0xFF74 Power unit fatal error		Keypad display: PU fatal error
Cause	Error type/response	Remedy
Error when reading the data from the power unit.	Fault <ul style="list-style-type: none"> - Operation of the VSD is not possible. 	<ul style="list-style-type: none"> - Switch VSD off and on again. - If the error occurs again, the manufacturer must be contacted, since the control unit or the device has to be replaced.

65413 0xFF85 Keypad full control active		Keypad display: Keypad full ctrl
Cause	Error type/response	Remedy
If the "Keypad Full Control" control mode is active.	Warning <ul style="list-style-type: none"> - Both the activity of controlling and the setpoint selection are carried out via the key-pad. 	Clicking the CTRL keypad key stops the control mode again.

7 UPDATE DEVICE FIRMWARE

The device firmware is continuously improved by the manufacturer. New firmware versions contain error corrections, function extensions and simplify the handling.

A new firmware is always compatible with the older version:

- A device with updated firmware and unchanged parameter settings shows the same behaviour as before.
- Parameter settings must only be adapted if new functions are used.

Requirements

To update the firmware of VLB3 is necessary:



1. The optional USB module, type code VLBXC02
2. A USB 2.0 cable (A plug on Micro-B plug).
3. The software VLBXSW, freely downloadable from the website www.LovatoElectric.com in the section Downloads > Software & upgrades > Variable speed drives.

Notes

- The voltage supply of the VLBXC02 module takes place via the USB connection.
- The communication must not be interrupted during the firmware download.
- The firmware update procedure can be done on VLB3 variable speed drivers with firmware revision >=4.1.

Details

Together with the VLBXSW software, the following tools are installed as well:

Tool	Brief description
 VLBXS00 (package manager)	Enables the installation of the following packages ("Packages for VLBXSW", downloadable from Lovato Electric website): <ul style="list-style-type: none"> - drivers for VLBXS01 software - firmware files for variable speed drives.
 VLBXS01 (configuration software)	Software for the parameter settings and monitoring of the variable speed drive.
 VLBXS02 (firmware loader)	Enables the update of the firmware for variable speed drives. <ul style="list-style-type: none"> - The update can be made by the mechanical engineer or the end user depending on the access protection set for the device.

Procedure for the firmware update

1. Download the file "Packages for VLBXSW" from the Lovato Electric website, section Downloads > Software & upgrades > Variable speed drives and extract the content in a folder on your PC.

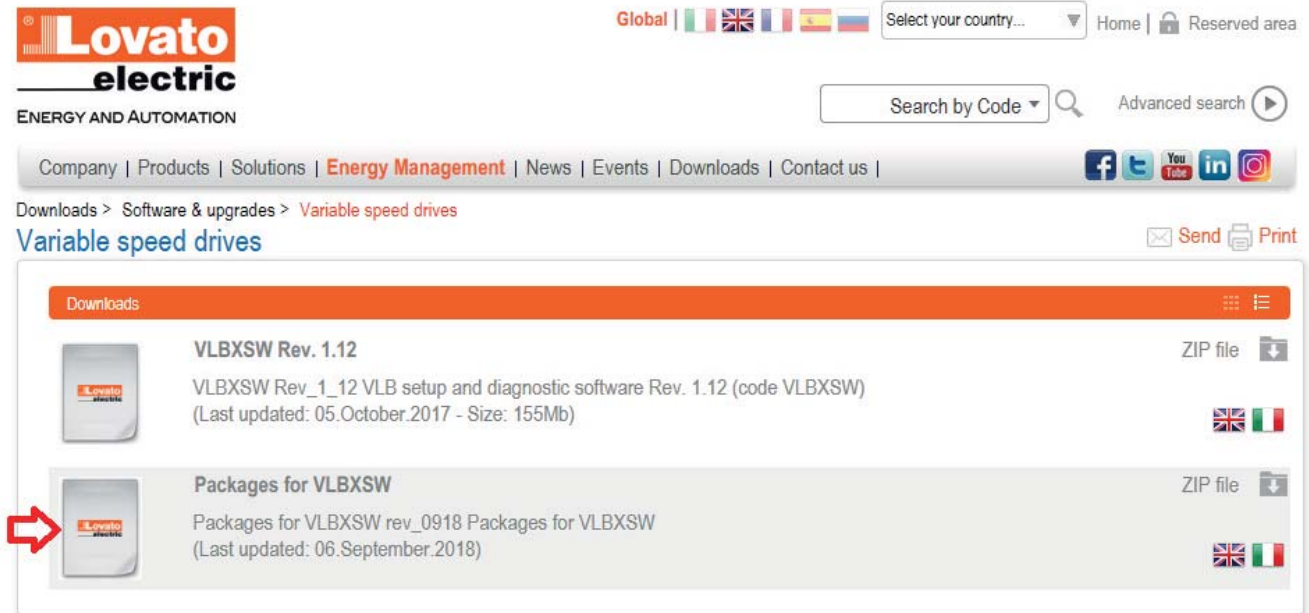

The screenshot shows the Lovato Electric website interface. At the top, there is a navigation bar with the Lovato Electric logo, a language selector (Global, UK, France, Spain, Italy), a search bar, and social media icons. Below the navigation bar, there is a breadcrumb trail: Downloads > Software & upgrades > Variable speed drives. The main content area displays a list of downloads under the heading 'Variable speed drives'. Two items are listed:

- VLBXS00 Rev. 1.12**: VLBXS00 Rev_1_12 VLB setup and diagnostic software Rev. 1.12 (code VLBXS00) (Last updated: 05.October.2017 - Size: 155Mb)
- Packages for VLBXSW**: Packages for VLBXSW rev_0918 Packages for VLBXSW (Last updated: 06.September.2018)

A red arrow points to the 'Packages for VLBXSW' item, indicating it is the target for download.

2. Import the packages using the software VLBXSW00 (package manager):
Open the VLBXSW00 software → clic on the button "Import" → Select the folder which contains the packages previously downloaded → Clic on the button "Install".
The device description files and firmware files will appears in the window "Installed packages".
Close the VLBXSW00 software.

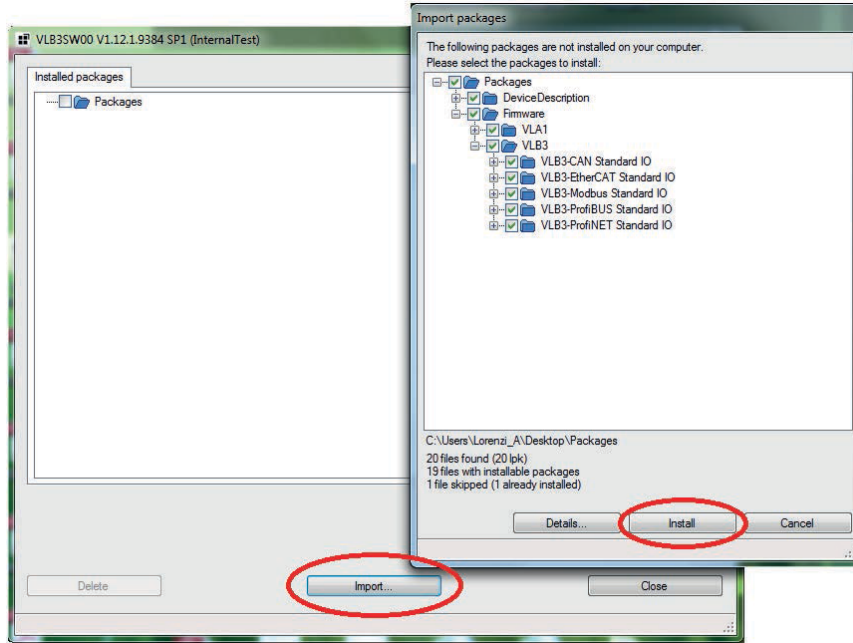

3. Connect the USB module VLBXC02 to the VLB3 drive to be updated and connect the USB cable to the PC. The green LED "USB/Power" on VLBXC02 will light up.
4. Open the VLBXSW02 software (firmware loader)



5. Select the firmware file to import in the VLB3 according to the type model in your possession (in this example: VLB3 with Modbus RTU logic unit, firmware 5.1) and press "Next" button.

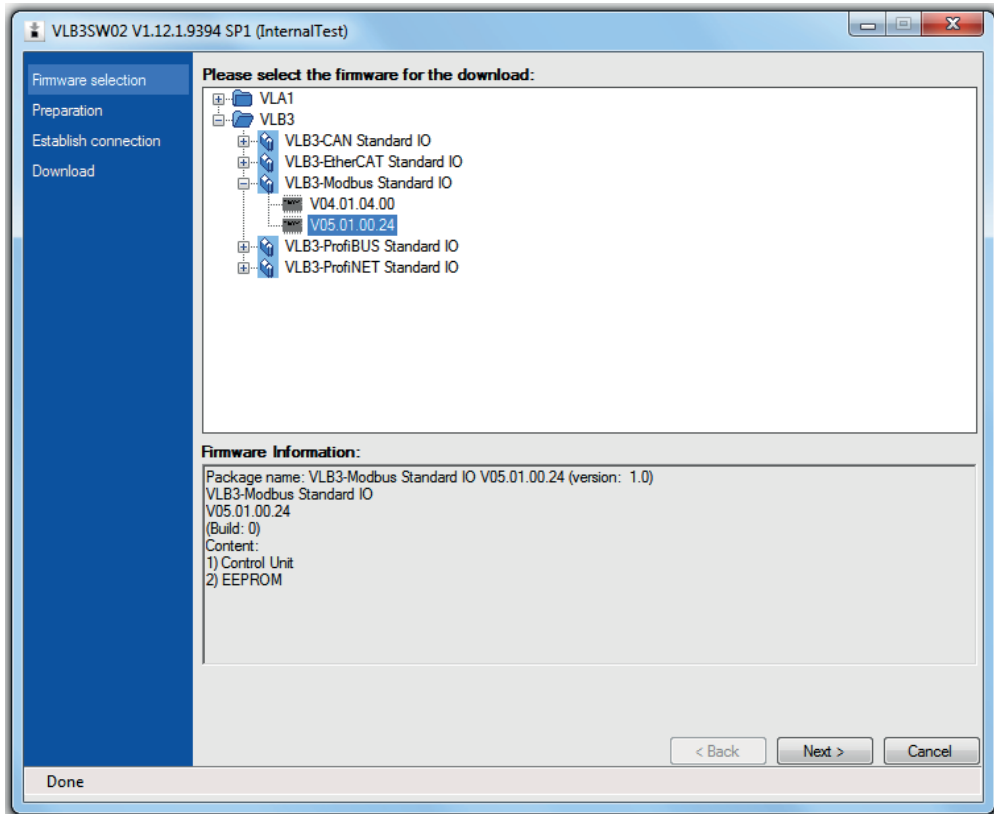

6. The software will detect the type code and firmware version of your drive. Press "Next" button to proceed with the firmware update.

Notes:

- The firmware download will not take more than 20 seconds. The progress is shown in the VLBXSW02 window.
- After the firmware download, the connection to the device gets lost for some second and is then restored again automatically.
- Device settings are not changed by the firmware download.
- The brand protection does not get lost by the firmware download.
- The firmware can neither be exported from the device nor be deleted from the device.

If the connection is aborted during the firmware download, this may have the following consequences:

- The device starts with the old firmware. The firmware download can be restarted.
- The firmware in the device is damaged. Consultation with the manufacturer is required.

8 Safe Torque Off (STO) module

The motor cannot generate torque and movements of the drive.

⚠ DANGER!

Automatic restart if the request of the safety function is deactivated.

Possible consequences: Death or severe injuries

► You must provide external measures according to EN ISO 13849-1 which ensure that the drive only restarts after a confirmation.

⚠ DANGER!

The power supply is not safely disconnected.

Possible consequences: Death or serious injury due to electrical voltage.

► Turn off the power supply.

Preconditions

The VLB3 variable speed drive must be equipped with the optional STO module, type code VLBXSM.

Details

Safe disconnection of the drive

1. A safety sensor requests the safety function.

2. The pulse width modulation is safely switched off by the safety unit.

The VSD switches to the STO active device status (0x6041, Bit15 = 0).

The power drivers do not generate a rotating field anymore.

The motor is safely switched to torqueless operation (STO).

i The functional principle depicted applies to Basic Safety (STO) and Extended Safety. The terminals shown apply to Basic Safety.

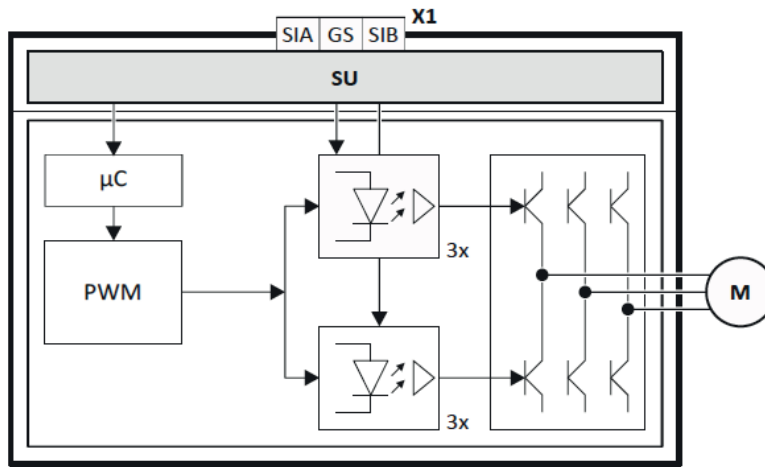

Functional principle of safety technology for Extended Safety and Basic Safety (STO)

- X1 Control terminals of the safety unit
- SU Basic Safety (STO) or Extended Safety
- µC Microcontroller
- PWM Pulse width modulation
- M Motor

Functional description

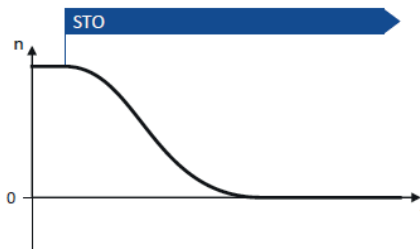

i Functional sequence and error response have no adjustable parameters.

Truth table

Safe input / channel		Drive	Drive status word		CiA402 status word
SIA	SIB	Device status	Bit 55	Bit 155	Object 0x6041, bit 15
LOW	LOW	STO active	1	1	0
LOW	HIGH	Impermissible state	1	0	0
HIGH	LOW	Impermissible state	1	0	0
HIGH	HIGH	Drive enabled	0	0	1

i If the GS connection is interrupted or in case of a short circuit/short circuit of GS to SIA/SIB, STO is active.

9 MAINTENANCE

The VLB3 VSD does not require any maintenance if the prescribed operating conditions are observed.

9.1 ROUTINE INSPECTIONS

NOTICE!

It is a good practice to check the VSD during a routine inspection of the drive system:

- ▶ Remove dust from VSD housing if necessary.
- ▶ Check that ventilation slots are not covered or obstructed.
- ▶ Check the condition and tightness of the electric connections.
- ▶ The integrity of all earth / ground connections should be periodically checked.

DANGER!

Dangerous electrical voltage

Possible death or severe injuries due to electrical shock.

- ▶ All inspection works on the VSD must only be carried out in the deenergised state.
- ▶ After switching off the mains voltage, the capacitors in the VSD can still be charged. Observe the waiting time on the VSD label before commencing work.

9.2 PRODUCT SUPPORT

LOVATO Electric S.p.A.

Via Don E. Mazza, 12
24020 Gorle, Bergamo, Italy

Phone: +39 0354282422

Fax: +39 0354282295

Email: service@LOVATOElectric.com

10 DECOMMISSIONING

10.1 SAFETY INSTRUCTIONS

WARNING!

Dangerous electrical voltage

An electrical shock can cause death or severe personal injury.

- ▶ Apply lockout/tagout procedures for decommissioning.
- ▶ Connect/disconnect all pluggable VSD connections only in deenergised condition!
- ▶ Only remove the VSD from the installation in completely deenergised state.

10.2 REMOVAL AND DISPOSAL

Recycle metal and plastic materials of the VSD. Ensure professional disposal of assembled PCBs.

-  Observe all applicable national regulations for the disposal of waste electronic equipment.